

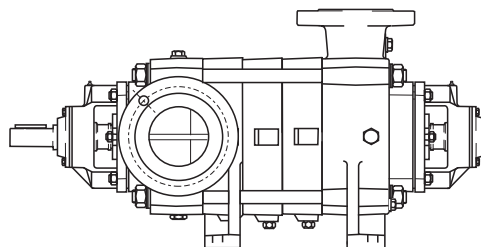

STAINLESS STEEL HIGH PRESSURE HORIZONTAL
MULTI-STAGE PUMPS
*ГОРИЗОНТАЛЬНЫЕ МНОГОСТУПЕНЧАТЫЕ
НАСОСЫ ВЫСОКОГО ДАВЛЕНИЯ ИЗ
НЕРЖАВЕЮЩЕЙ СТАЛИ*
**POMPE MULTISTADIO ORIZZONTALI AD ALTA
PRESSIONE IN ACCIAIO INOX**

PMXT



caprari

pumping power

ISO 9001
ISO 14001
ISO 45001
BUREAU VERITAS
Certification



Technical data - <i>Технические данные</i> - Dati tecnici	3
Pump coding - <i>Пояснения к обозначениям</i> - Esemplificazione sigla	3
Executions on demand - <i>Исполнение под заказ</i> - Esecuzione a richiesta	6
Technical data standardized enclosed electric motors (indicatives values according to the type of motor installed) - <i>Технические данные нормализованных электродвигателей (приблизительные значения в зависимости от марки двигателя)</i> - Dati tecnici motore elettrico chiuso normalizzato (valori indicativi in funzione della marca di motore utilizzato)	6
Performance ranges - <i>Диапазон рабочих параметров</i> - Campi di prestazione	7
Construction and materials - <i>Конструкция и материалы</i> - Costruzione e materiali	8
PMXT50	
• Technical data, operating data at 1450, 1750, 2000, 2200, 2900, 3500 n [min ⁻¹] <i>Технические данные, рабочие характеристики при 1450, 1750, 2000, 2200, 2900, 3500 об. [мин⁻¹]</i> Dati tecnici, caratteristiche di funzionamento a 1450, 1750, 2000, 2200, 2900, 3500 n [min⁻¹]	11
• Overall dimensions and weights - <i>Общие габариты и вес</i> - Dimensioni di ingombro e pesi	17
• Selection, dimensions and weights for base mounted electric pumps - <i>Подбор, габариты и вес электронасосов на раме</i> Selezione, dimensioni e pesi elettropompe su base	18
PMXT65	
• Technical data, operating data at 1450, 1750, 2000, 2200, 2900, 3500 n [min ⁻¹] <i>Технические данные, рабочие характеристики при 1450, 1750, 2000, 2200, 2900, 3500 об. [мин⁻¹]</i> Dati tecnici, caratteristiche di funzionamento a 1450, 1750, 2000, 2200, 2900, 3500 n [min⁻¹]	23
• Overall dimensions and weights - <i>Общие габариты и вес</i> - Dimensioni di ingombro e pesi	29
• Selection, dimensions and weights for base mounted electric pumps - <i>Подбор, габариты и вес электронасосов на раме</i> Selezione, dimensioni e pesi elettropompe su base	30
PMXT80	
• Technical data, operating data at 1450, 1750, 2000, 2200, 2900, 3500 n [min ⁻¹] <i>Технические данные, рабочие характеристики при 1450, 1750, 2000, 2200, 2900, 3500 об. [мин⁻¹]</i> Dati tecnici, caratteristiche di funzionamento a 1450, 1750, 2000, 2200, 2900, 3500 n [min⁻¹]	35
• Overall dimensions and weights - <i>Общие габариты и вес</i> - Dimensioni di ingombro e pesi	40
• Selection, dimensions and weights for base mounted electric pumps - <i>Подбор, габариты и вес электронасосов на раме</i> Selezione, dimensioni e pesi elettropompe su base	41
PMXT100	
• Technical data, operating data at 1450, 1750, 2000, 2200, 2900, 3500 n [min ⁻¹] <i>Технические данные, рабочие характеристики при 1450, 1750, 2000, 2200, 2900, 3500 об. [мин⁻¹]</i> Dati tecnici, caratteristiche di funzionamento a 1450, 1750, 2000, 2200, 2900, 3500 n [min⁻¹]	47
• Overall dimensions and weights - <i>Общие габариты и вес</i> - Dimensioni di ingombro e pesi	53
• Selection, dimensions and weights for base mounted electric pumps - <i>Подбор, габариты и вес электронасосов на раме</i> Selezione, dimensioni e pesi elettropompe su base	54
PMXLT125	
• Technical data, operating data at 1450, 1750, 2000, 2200, 2900 n [min ⁻¹] <i>Технические данные, рабочие характеристики при 1450, 1750, 2000, 2200, 2900 об. [мин⁻¹]</i> Dati tecnici, caratteristiche di funzionamento a 1450, 1750, 2000, 2200, 2900 n [min⁻¹]	59
• Overall dimensions and weights - <i>Общие габариты и вес</i> - Dimensioni di ingombro e pesi	64
• Selection, dimensions and weights for base mounted electric pumps - <i>Подбор, габариты и вес электронасосов на раме</i> Selezione, dimensioni e pesi elettropompe su base	65
PMXT125	
• Technical data, operating data at 1450, 1750, 2000, 2200, 2900 n [min ⁻¹] <i>Технические данные, рабочие характеристики при 1450, 1750, 2000, 2200, 2900 об. [мин⁻¹]</i> Dati tecnici, caratteristiche di funzionamento a 1450, 1750, 2000, 2200, 2900 n [min⁻¹]	69
• Overall dimensions and weights - <i>Общие габариты и вес</i> - Dimensioni di ingombro e pesi	74
• Selection, dimensions and weights for base mounted electric pumps - <i>Подбор, габариты и вес электронасосов на раме</i> Selezione, dimensioni e pesi elettropompe su base	75
PMXLT150	
• Technical data, operating data at 1150, 1450, 1750, 2000, 2900 n [min ⁻¹] <i>Технические Данные, рабочие характеристики при 1450, 1750, 2000, 2200, 2900 об. [мин⁻¹]</i> Dati tecnici, caratteristiche di funzionamento a 1150, 1450, 1750, 2000, 2900 n [min⁻¹]	79
• Overall dimensions and weights - <i>Общие габариты и вес</i> - Dimensioni di ingombro e pesi	85
• Selection, dimensions and weights for base mounted electric pumps - <i>Подбор, габариты и вес электронасосов на раме</i> Selezione, dimensioni e pesi elettropompe su base	86
PMXT150	
• Technical data, operating data at 1150, 1450, 1750, 2000 n [min ⁻¹] <i>Технические Данные, рабочие характеристики при 1450, 1750, 2000, 2200, 2900 об. [мин⁻¹]</i> Dati tecnici, caratteristiche di funzionamento a 1150, 1450, 1750, 2000 n [min⁻¹]	89
• Overall dimensions and weights - <i>Общие габариты и вес</i> - Dimensioni di ingombro e pesi	93
• Selection, dimensions and weights for base mounted electric pumps - <i>Подбор, габариты и вес электронасосов на раме</i> Selezione, dimensioni e pesi elettropompe su base	94
Flanges (UNI EN 1092-2) - <i>Фланцы (UNI EN 1092-2)</i> - Flange (UNI EN 1092-2)	95

CONSTRUCTION

- Multistage, horizontal shaft, centrifugal pumps driven by means of either a flexible coupling or hydraulic drive, clockwise rotation viewed from the driven side, comprising:
- Suction casing with positionable inlet. - Intermediate stage composed of:
 - shell with water draining plug, diffuser fitted with renewable wear rings, radial impeller with axial thrust compensation.
 - Delivery casing with mounting-feet and discharge outlet pointing upwards.
 - Completely protected stainless steel shaft.
 - Shaft seals of the mechanical PMX(S/H)T versions); chambers sized in compliance with DIN 24960 and ISO 3069 standards.
 - Four external tie-bolts clamp the stages in a rigid construction.

SPECIAL FEATURES

- Balanced rotating parts for increased life and reliability
- Pressure balancing device by throttling bushes.
- Generously sized ball bearings (grease lubricated), able to carry both radial and axial thrust in both directions.
- Standard shaft heights (UNI 2946 and ISO 496) according to the ones of the electric motors.

MAIN USES

- Water conveying in industrial systems, pipe-line transfer and civil use.
- Artificial snow.
- Fire-fighting service.
- Pressure boosting.
- Irrigation.
- Desalination.

RANGE SIZE AND OPERATING LIMITS

- 8 sizes, from DNm 50 to DNm 150;
- Operating pressure of up to 100 bar and flow rates of up to 160 [l/s];
- suction flanges: PN25 for the PMX(S)Tversions PN40 for the PMXHT version
- Delivery flanges: PN40 for the PMXT version PN63 for the PMXST version PN100 for the PMXHT version

КОНСТРУКЦИЯ

- Многоступенчатые центробежные насосы с горизонтальной осью, привод через эластичную или гидродинамическую муфту, с вращением по часовой стрелке, смотря со стороны электрошпингалта, состоящие из:
- Всасывающего корпуса с поворотным патрубком.
 - Промежуточной ступени, состоящей из:
 - корпуса со сливной пробкой, диффузора с заменяемыми кольцами, радиального рабочего колеса с компенсацией осевой тяги.
 - Напорного корпуса с опорными ножками и напорным патрубком, направленным вверх.
 - Полностью защищенного вала из нержавеющей стали.
 - Компактных опорных подшипников с высокой жесткостью.
 - Механического уплотнения на валу PMX(S/H)T; размеры камер в соответствии с DIN 24960 и ISO 3069.
 - 4 внешних стяжных болта для затяжки промежуточных ступеней;

ОСОБЕННОСТИ

- Сбалансированные вращающиеся элементы для повышения надежности и долговечности.
- Барабан для прокатки и балансировки.
- Шарикоподшипники (смазываемые консистентной смазкой) с большими размерами для выдерживания как радиальных, так и осевых нагрузок в обоих направлениях.
- Стандартные высоты оси (UNI 2946 и ISO 496), как для электродвигателей.

ОСНОВНЫЕ ОБЛАСТИ ПРИМЕНЕНИЯ

- Перекачка воды в системах промышленного, водопроводного и гражданского назначения
- Системы искусственного снега
- Пожаротушение
- Повышение давления
- Орошение
- Опреснение

АССОРТИМЕНТ И ОГРАНИЧЕНИЯ СЕРИИ

- 8 размеров от DNm 50 до DNm 150;
- Рабочее давление до 100 бар и расход до 160 [л/с];
- Всасывающий фланец: PN25 версии PMX(S)T / PN40 версия PMXHT
- Напорный фланец: PN40 версия PMXT / PN63 версия PMXST / PN100 версия PMXHT

COSTRUZIONE

- Pompe centrifughe multistadio ad asse orizzontale, azionamento tramite giunto elastico o idrodinamico, con rotazione oraria vista lato comando, costituite da:
- Corpo di aspirazione con bocca orientabile.
 - Stadio intermedio costituito da:
 - mantello con tappo di scarico, diffusore dotato di anelli sede girante sostituibili, girante radiale con compensazione della spinta assiale.
 - Corpo di mandata con piedi di sostegno e con bocca premente orientata verso l'alto.
 - Albero in acciaio inox completamente protetto.
 - Supporti cuscinetti ad elevata rigidità e compattezza.
 - Tenute sull'albero del tipo meccanico PMX(S/H)T; dimensionamento delle camere secondo DIN 24960 ed ISO 3069.
 - Quattro tiranti esterni per serraggio degli stadi intermedi;

PECULIARITA'

- Elementi rotanti equilibrati per aumentare affidabilità e durata.
- Tamburo di laminazione e bilanciamento.
- Cuscinetti a sfere (lubrificati a grasso) ampiamente dimensionati per la supportazione sia dei carichi radiali che assiali in entrambe le direzioni.
- Altezze d'asse normalizzate (UNI 2946 ed ISO 496) come per i motori elettrici.

PRINCIPALI IMPIEGHI

- Convogliamento di acqua negli impianti per uso industriale, acquedottistico e civile.
- Impianto di innnevamento.
- Servizio antincendio.
- Sopraelevazione di pressione. - Irrigazione.
- Dissalazione.

AMPIEZZA E LIMITI DELLA SERIE -

- n° 8 grandezze da DNm 50 a DNm 150;
- Pressione di esercizio fino a 100 bar e portate fino a 160 [l/s];
- Flangia di aspirazione: PN25 versioni PMX(S)T PN40 versione PMXHT
- Flangia di mandata: PN40 versione PMXT PN63 versione PMXST PN100 versione PMXHT

PUMP CODING
Пояснения к обозначениям
ESEMPLIFICAZIONE SIGLA

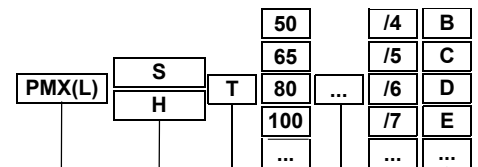

Series PMX(L) (Stainless steel) - Серия PMX(L) (Нержав. сталь) - Serie PMX(L) (Acciaio inox)

S = Flange of the delivery outlet PN63 - S = Фланец патрубка подающей части PN63
 S = Flangia della bocca di mandata PN63
 H = Flange of the delivery outlet PN100 - H = Фланец патрубка подающей части PN100
 H = Flangia della bocca di mandata PN100

Balanced standardized DIN 24960 and ISO 3069 mechanical seals on the shaft - Мех. уплотнения на валу, сбалансированные, нормализованные DIN 24960 et ISO 3069 - Tenute sull'albero meccaniche, bilanciate, normalizzate DIN 24960 ed ISO 3069

Nominal diameter (mm) of delivery port - Номинальный диаметр (мм) выходного отверстия - Diametro nominale (mm) bocca premente

Executions on demand - Исполнение под заказ - Esecuzioni a richiesta

Number of stages - Кол-во ступеней - Numero degli stadi

Impeller trimming - Редукция раб. колеса - Riduzione giranti

Pumps suitable for clean, chemically and mechanically non-aggressive water for materials of the components.

Насосы, пригодные для перекачивания пресной воды, химически и механически неагрессивной по отношению к материалам компонентов.

Pompe adatte al pompaggio di acqua dolce, pulita chimicamente e meccanicamente non aggressiva per i materiali dei componenti.

Maximum permissible power: in relation to the number of impellers at a set rotation speed, the power input of the selected pump must be compatible to the maximum permissible power P₂ max.

Максимальная допустимая мощность: в зависимости от количества рабочих колес выбранного насоса при определенной скорости вращения необходимо проверить, что потребляемая мощность соответствует максимальной допустимой мощности P₂ max.

Massime potenze ammissibili: in funzione del numero giranti della pompa selezionata ad una determinata velocità di rotazione, verificare che la potenza assorbita sia compatibile con la massima potenza ammessa P₂ max.

Example - *Пример* - **Esempio:**

PM100 N/n = 0,08

Speed - *Скорость* - **Velocità n [min⁻¹] = 2965**

P₂ max. = 0,08 x 2965 = 237 [Kw]

- Maximum content of solid substances of silt grain size and hardness with seal: with packing = 20 0 [g/m³]; mechanica = 0 [g/m³]

Максимальное содержание твердых веществ, твердость и гранулометрический состав ила: сальник = 20 [г/м³]; мех. уплотнение = 0 [г/м³]

Contenuto massimo di sostanze solide della durezza e granulometria del limo con tenuta: a baderna = 20 [g/m³]; meccanica = 0 [g/m³]

- Max. temperature of pumped liquid: 90°C

Максимальная температура перекачиваемой жидкости: 90 °C

Temperatura max. liquido sollevato: 90°C

- Operating max. time with closed port and liquid at 40°C: 2+6 min (2 min 3500g/1' - 6 min 1450g/1')

Макс. время работы при закрытом выходе с температурой жидкости 40 °C: 2+6 мин (2 мин. - 3500 об/мин.; 6 мин. - 1450 об/мин.)

Tempo max. di funzionamento a bocca chiusa con liquido a 40°C: 2+6 min (2 min 3500g/1' - 6 min 1450g/1')

- Operating max. time with closed port and liquid at 90°C: min "0"

Максимальное время работы при закрытом нагнетании с температурой жидкости 90 °C: мин. «0»

Tempo max. di funzionamento a bocca chiusa con liquido a 90°C: min "0"

- Direction of rotation: clockwise viewed from drive side

Направление вращения: по часовой стрелке, если смотреть со стороны электрощитка

Senso di rotazione: orario visto dal lato comando

- Approved paints for use with drinking water

Краски, сертифицированные для перекачки питьевой воды.

Vernici omologate per convogliamento di acqua potabile

- Port positioning: radial suction port normally pointing to the right, as viewed from control side. On request, it can be positioned either upwards or towards the left / radial delivery port pointing upwards

Ориентация патрубков: всасывание - радиальная, обычно повернуто вправо, если смотреть со стороны электрощитка, или по запросу может быть повернуто вверх или влево / выход - радиальная, повернуто вверх.

Orientamento bocche: aspirante radiale normalmente rivolta a destra, vista lato comando, orientabile su richiesta verso l'alto oppure a sinistra/premente radiale rivolta verso l'alto

- For pump driven by i.c. engine the use of a clutch is advised

При соединении насосов с тепловыми двигателями целесообразно предусмотреть сцепление.

Per accoppiamenti a motori endotermici, è buona norma che il motore sia corredato di frizione

- Always state the complete pump code on order, as indicated in the PUMP CODING paragraph.

При заказе всегда указывайте полный код насоса, как показано в примере ПОЯСНЕНИЯ К ОБОЗНАЧЕНИЯМ.

In sede d'ordine precisare sempre la sigla della pompa completa secondo la esemplificazione indicata nel paragrafo ESEMPLIFICAZIONE DELLA SIGLA.

Tolerances

Service conditions have been measured with cold water (15°C) at 1 bar atmospheric pressure. These tolerances are guaranteed with standard assembly line pumps built according to UNI/ISO 9906 Grade 3B. Catalogue data are for liquids with a density of 1 kg/dm³, and kinematic viscosity not exceeding 1 mm²/s. If requested the pump can be tested according to UNI/ISO 9906 Grade 2B standards.

Допуски

Рабочие характеристики измерены с использованием холодной воды (15°C) при атмосферном давлении (1 бар) и гарантированы с учетом того, что речь идет о серийных насосах, изготовленных в соответствии со стандартами UNI/ISO 9906 Уровень 3B. Данные в каталоге относятся к жидкостям с плотностью 1 кг/дм³ и кинематической вязкостью, равной или меньшей 1 мм²/с. По запросу характеристики могут быть гарантированы в соответствии со стандартами UNI/ISO Уровень 2B.

Tolleranze

Le caratteristiche di funzionamento sono state rilevate con acqua fredda (15°C.) alla pressione atmosferica (1bar) e vengono garantite, trattandosi di pompe costruite in serie, secondo le norme UNI/ISO 9906 Grado 3B. I dati di catalogo si riferiscono a liquidi con densità di 1kg/dm³ e con viscosità cinematica non superiore a 1mm²/s. Su richiesta, le pompe possono essere collaudate secondo le norme UNI/ISO 9906 Grado 2B.

Seal limit

Test to ascertain the maximum pressure acting on the seals.

Пределы уплотнений

Проверка максимального давления, действующего на уплотнения.

Limiti tenute

Verifica della massima pressione agente sulle tenute.

Test to ascertain the maximum pressure acting on the seals
Проверка максимального давления, действующего на уплотнения
Verifica della massima pressione agente sulle tenute

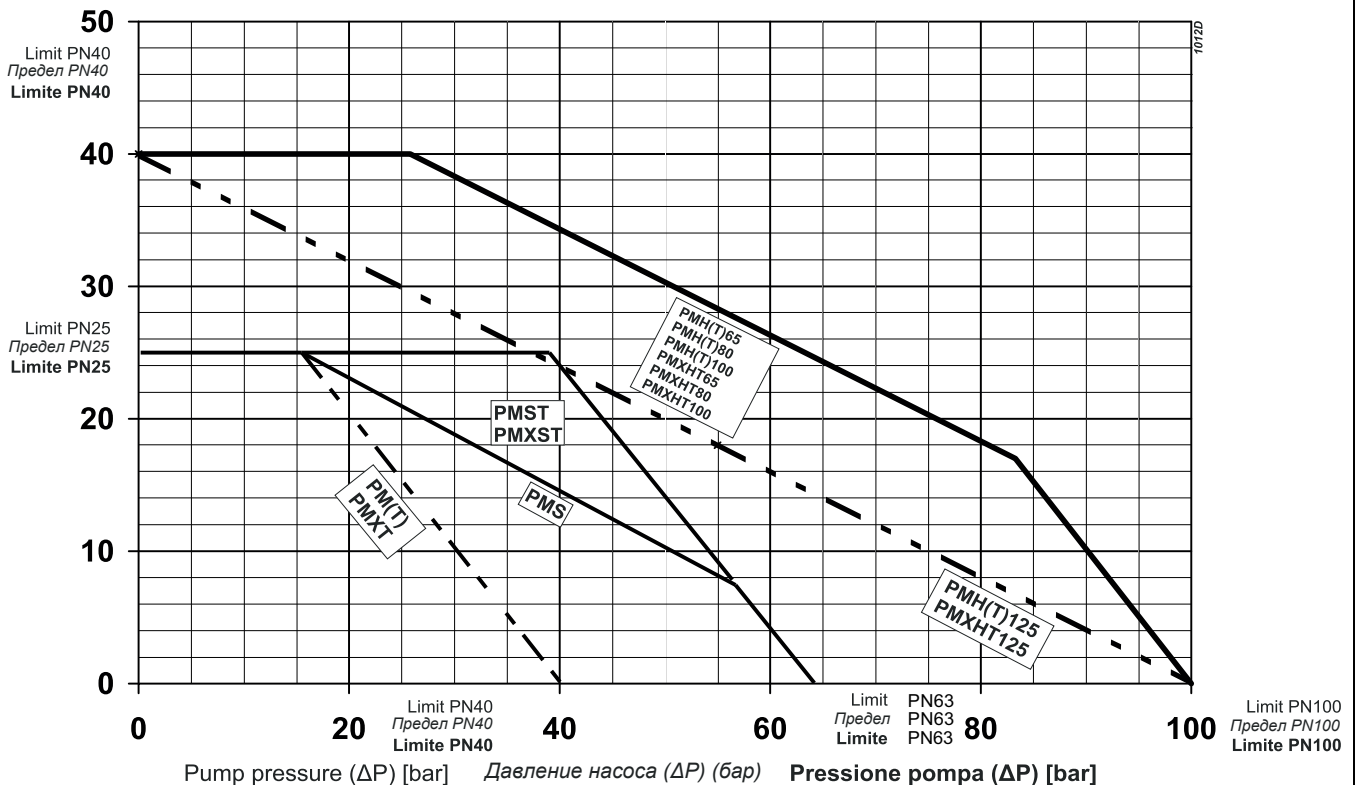

Total pressure = Max. suction pressure + Pump pressure (ΔP).
With special packing (PM...B/...), use the PMT curves for PM; use the PMST curve.

Общий напор = макс. давление на всасывании + давление насоса (ΔP).
При использовании специальной набивки сальника (PM...B/...), для PM используйте кривые PMT; для PMS используйте кривые PMST.

Pressione Totale = Pressione Max. in aspirazione + pressione pompa (ΔP).
Con la baderna speciale (PM...B/...), per la PM utilizzare le curve della PMT; per la PMS le curve della PMST.

PMX ... A / ...	=	Anticlockwise rotation (shaft projection on delivery side) - Направление вращения против часовой стрелки (выход вала со стороны нагнетания) - Rotazione antioraria (sporgenza albero lato mandata)
PMX ... C / ...	=	With thermal probes - <i>С термодатчиками</i> - Con sonde termiche
PMX ... D / ...	=	With double shaft projection - <i>С двойным выступом вала</i> - Con doppia sporgenza d'albero
PMX ... L / ...	=	With suction point port pointing upwards (PMXT50, PMXT65, PMXT80, PMXL125, PMXL100 2 stages and PMXT125 3 stages excluded) - <i>Всасывающ. патрубок ориентирован вверх (исключая PMXT50, PMXT65, PMXT80, PMXL125, PMXL100 2 ступени и PMXT125 3 ступени).</i> Con bocca di aspirazione rivolta verso l'alto (escluse PMXT50, PMXT65, PMXT80, PMXL125, PMXL100 2 stadi e PMXT125 3 stadi)
PMX ... M / ...	=	With suction port pointing towards the left (viewed from suction side) - <i>Всасывающий патрубок ориентирован влево (смотря со стороны всасывания)</i> - Con bocca di aspirazione rivolta a sinistra (vista lato aspirazione)
Others on request - Другие варианты под заказ - Altre su richiesta		

Technical data standardized enclosed electric motors (indicatives values according to the type of motor installed)
Технические данные нормализованных закрытых электродвигателей (приблизит. значения в зависимости от марки двигателя)
Dati tecnici motore elettrico chiuso normalizzato (valori indicativi in funzione della marca di motore utilizzato)

Motor power Мощность двигателя Potenza motore	2 Poles 50 Hz 2 Полюса 50 Гц 2 Poli 50 Hz			4 Poles 50 Hz 4 Полюса 50 Гц 4 Poli 50 Hz		
	Max. number starts/hour* Макс. кол-во пусков в час* Numero massimo di avviamenti/ora*	Voltage variation Изменение напряжения Variazione di tensione	Dinamic momentum J Динамический момент J Momento dinamico J	Max. number starts/hour* Макс. кол-во пусков в час* Numero massimo di avviamenti/ora*	Voltage variation Изменение напряжения Variazione di tensione	Dinamic momentum J Динамический момент J Momento dinamico J
[kW]		[%]	[kg m ²]		[%]	[kg m ²]
0,75	3	± 10 (400V)	0,001	3	± 10 (400V)	0,003
1,1	3	± 10 (400V)	0,002	3	± 10 (400V)	0,004
1,5	3	± 10 (400V)	0,002	3	± 10 (400V)	0,005
2,2	3	± 10 (400V)	0,003	3	± 10 (400V)	0,01
3	3	± 10 (400V)	0,005	3	± 10 (400V)	0,013
4	3	± 10 (400V)	0,008	3	± 10 (400V)	0,02
5,5	3	± 10 (400V)	0,014	3	± 10 (400V)	0,035
7,5	3	± 10 (400V)	0,017	3	± 10 (400V)	0,047
11	3	± 10 (400V)	0,051	3	± 10 (400V)	0,107
15	3	± 10 (400V)	0,064	3	± 10 (400V)	0,129
18,5	3	± 10 (400V)	0,076	3	± 10 (400V)	0,19
22	3	± 10 (400V)	0,117	3	± 10 (400V)	0,226
30	3	± 10 (400V)	0,174	3	± 10 (400V)	0,361
37	3	± 10 (400V)	0,205	3	± 10 (400V)	0,63
45	3	± 10 (400V)	0,302	3	± 10 (400V)	0,738
55	3	± 10 (400V)	0,408	3	± 10 (400V)	1,024
75 ○	3	± 10 (400V)	0,677	3	± 10 (400V)	1,4723
90 ○	3	± 10 (400V)	0,8001	3	± 10 (400V)	1,6775
110 ○	3	± 10 (400V)	1,5379	3	± 10 (400V)	3,4327
132 ○	3	± 10 (400V)	1,8654	3	± 10 (400V)	3,9943
160 ○	3	± 10 (400V)	2,1504	3	± 10 (400V)	4,6494
200 ○	3	± 10 (400V)	2,3575	3	± 10 (400V)	5,0238
250	3	± 10 (400V)	3,812	3	± 10 (400V)	9,297
280	3	± 10 (400V)	3,812	3	± 10 (400V)	9,297
315	3	± 10 (400V)	4,463	3	± 10 (400V)	10,286
355	3	± 10 (400V)	4,463	3	± 10 (400V)	11,275
375	3	± 10 (400V)	5,58	3	± 10 (400V)	11,9

- Axial drive only, by flexible coupling.

- Только соосный привод с помощью упругой муфты.

- Azionamento solo coassiale tramite giunto elastico.

- Electric motor operating limits in compliance with IEC 34-1

- Пределы эксплуатации для электродвигателей в соответствии с IEC 34-1.

- Limiti d'utilizzo motore elettrico secondo IEC 34-1.

* Equally distributed.

* Рекомендуется равномерное распределение.

* Consigliati equamente ripartiti.

SPECIFICATIONS

Efficiency class: IE3

○ Motor in IE4 efficiency class according to EU REGULATION 2019/1781. Available in other efficiency classes for non-EU markets.

ХАРАКТЕРИСТИКИ

Класс эффективности: IE3

○ Двигатель класса эффективности IE4 в соответствии с РЕГЛАМЕНТОМ ЕС 2019/1781. Доступны другие классы эффективности для рынков за пределами ЕС.

CARATTERISTICHE

Classe di efficienza: IE3

○ Motore in classe di efficienza IE4 in conformità al REGOLAMENTO UE2019/1781. Disponibili in altre classi di efficienza per mercati extra UE.

Performance ranges
 Диапазон рабочих параметров
 Campi di prestazione

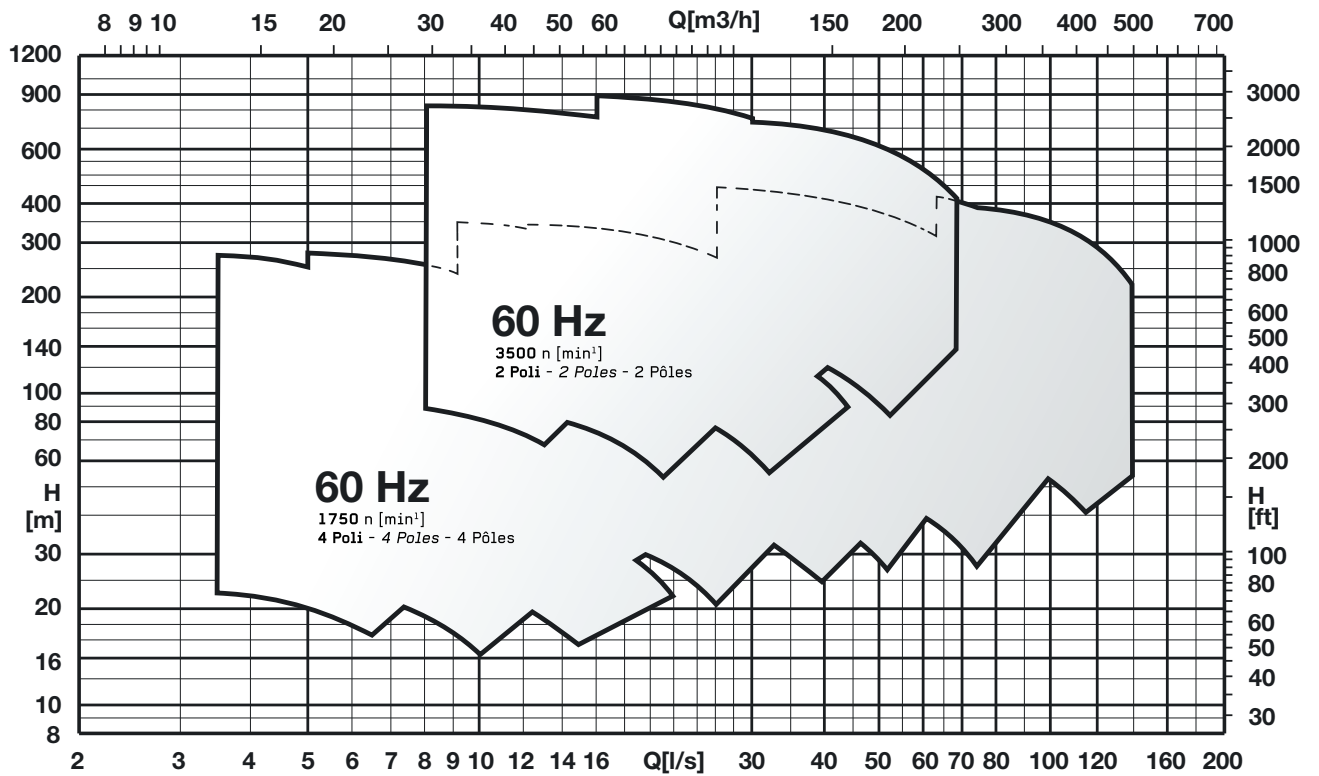
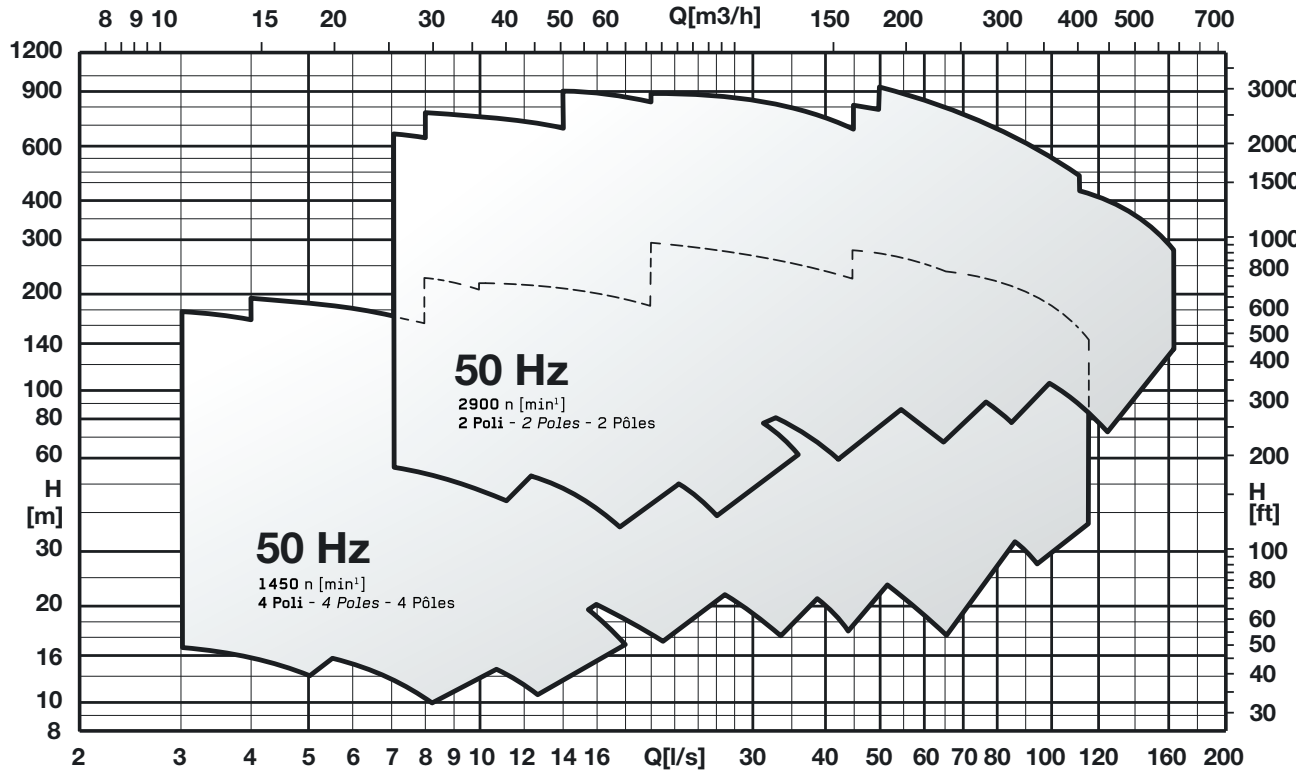

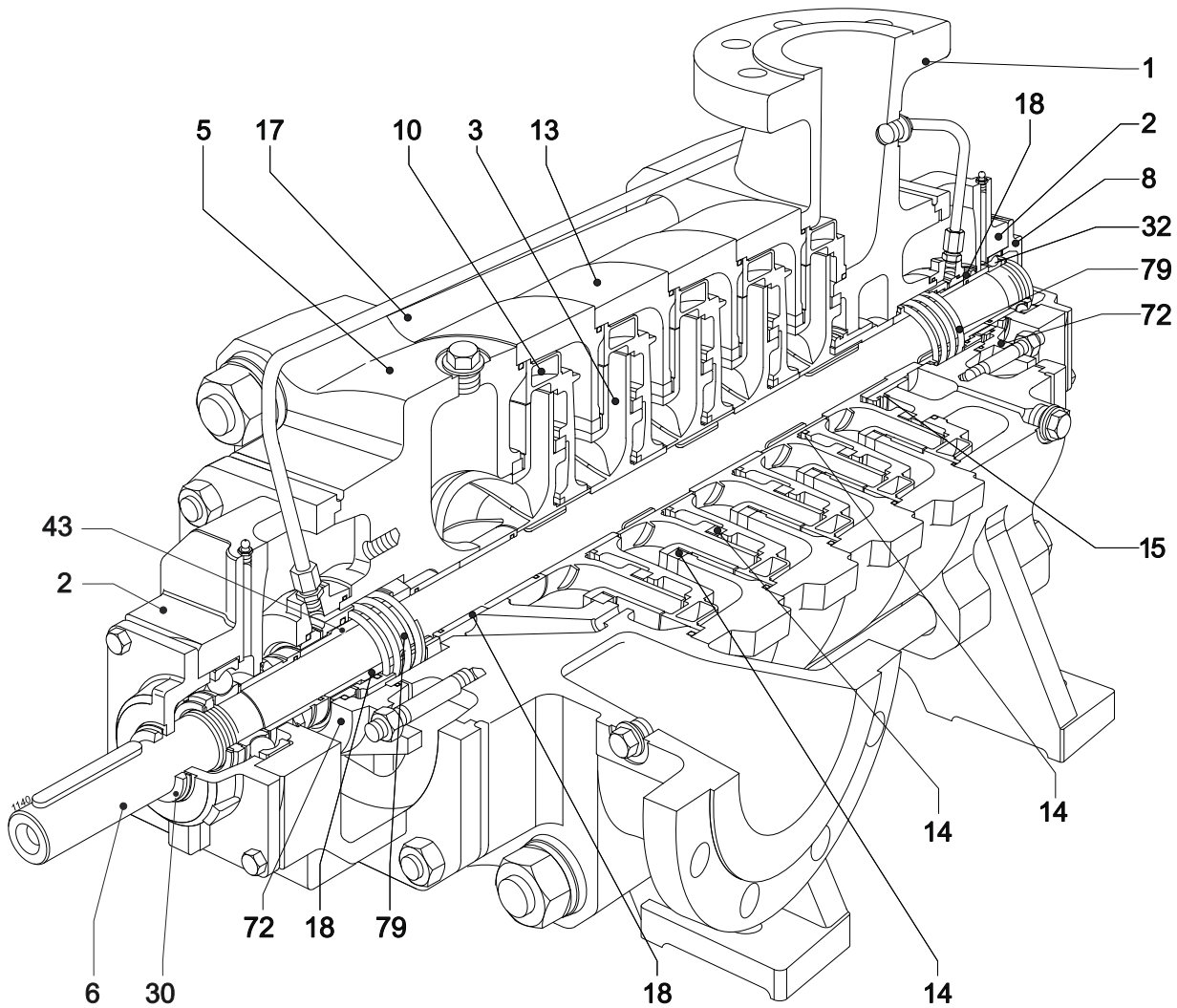

PMX(T)

Pos.	Parts	Materials	Компонент	Материал	Nomenclatura	Materiale
1	Delivery body	Stainless steel	Корпус подающей части	Нержав. сталь	Corpo mandata	Acciaio inox
2	Support bearing	Stainless steel	Опора подшипника	Нержав. сталь	Supporto cuscinetto	Acciaio inox
3	Impeller	Stainless steel	Раб. колесо	Нержав. сталь	Girante	Acciaio inox
5	Suction casing	Stainless steel	Корпус всасывающей части	Нержав. сталь	Corpo aspirazione	Acciaio inox
6	Pump shaft	Stainless steel	Вал насоса	Нержав. сталь	Albero pompa	Acciaio inox
8	Flange bearing	Stainless steel	Фланец подшипника	Нержав. сталь	Flangia cuscinetto	Acciaio inox
10	Diffuser	Stainless steel	Диффузор	Нержав. сталь	Diffusore	Acciaio inox
13	Stage casing	Stainless steel	Кожух	Нержав. сталь	Mantello	Acciaio inox
14	Impeller wear ring	Stainless steel	Износное кольцо	Нержав. сталь	Anello sede girante	Acciaio inox
15	Drum wear ring	Stainless steel	Износное кольцо барабана	Нержав. сталь	Anello di rasamento tamburo	Acciaio inox
17	Tie rod	Stainless steel	Стяжка	Нержав. сталь	Tirante	Acciaio inox
18	Shaft sleeve	Stainless steel	Втулка вала	Нержав. сталь	Bussola albero	Acciaio inox
30	V seal ring	Rubber	Уплотнит. кольцо V	Резина	Anello di tenuta V	Gomma
32	Bearing	Stainless steel	Подшипник	Нержав. сталь	Cuscinetto	Acciaio inox
43	OR Seal ring	Rubber	Уплотнит. кольцо OR	Резина	Anello di tenuta OR	Gomma
72	Flange for mechanical seal	Stainless steel	Несущий фланец мех. уплотнения	Нержав. сталь	Flangia porta tenuta meccanica	Acciaio inox
79	Mechanical seal	Silicon carbide/ graphite	Мех. уплотнение	Карбид кремния/ графит	Tenuta meccanica	Carburo di silicio/ grafite

Screws and nuts in stainless steel.

Винты и гайки из нержавеющей стали.

Viti e dadi in acciaio inox.

PMXS(T)

Pos.	Parts	Materials	Компонент	Материал	Nomenclatura	Materiale
1	Delivery body	Stainless steel	Корпус подающей части	Нержав. сталь	Corpo mandata	Acciaio inox
2	Support bearing	Stainless steel	Опора подшипника	Нержав. сталь	Supporto cuscinetto	Acciaio inox
3	Impeller	Stainless steel	Раб. колесо	Нержав. сталь	Girante	Acciaio inox
5	Suction casing	Stainless steel	Корпус всасывающей части	Нержав. сталь	Corpo aspirazione	Acciaio inox
6	Pump shaft	Stainless steel	Вал насоса	Нержав. сталь	Albero pompa	Acciaio inox
8	Flange bearing	Stainless steel	Фланец подшипника	Нержав. сталь	Flangia cuscinetto	Acciaio inox
10	Diffuser	Stainless steel	Диффузор	Нержав. сталь	Diffusore	Acciaio inox
13	Stage casing	Stainless steel	Кожух	Нержав. сталь	Mantello	Acciaio inox
14	Impeller wear ring	Stainless steel	Износное кольцо	Нержав. сталь	Anello sede girante	Acciaio inox
15	Drum wear ring	Stainless steel	Износное кольцо барабана	Нержав. сталь	Anello di rasamento tamburo	Acciaio inox
17	Tie rod	Stainless steel	Стяжка	Нержав. сталь	Tirante	Acciaio inox
18	Shaft sleeve	Stainless steel	Втулка вала	Нержав. сталь	Bussola albero	Acciaio inox
30	V seal ring	Rubber	Уплотнит. кольцо V	Резина	Anello di tenuta V	Gomma
32	Bearing	Stainless steel	Подшипник	Нержав. сталь	Cuscinetto	Acciaio inox
43	OR Seal ring	Rubber	Уплотнит. кольцо OR	Резина	Anello di tenuta OR	Gomma
72	Flange for mechanical seal	Stainless steel	Несущий фланец мех. уплотнения	Нержав. сталь	Flangia porta tenuta meccanica	Acciaio inox
79	Mechanical seal	Silicon carbide/ graphite	Мех. уплотнение	Карбид кремния/ графит	Tenuta meccanica	Carburo di silicio/ grafite

PMXH(T)

Pos.	Parts	Materials	Компонент	Материал	Nomenclatura	Materiale
1	Delivery body	Stainless steel	Корпус подающ части	Нержав. сталь	Corpo mandata	Acciaio inox
2	Support bearing	Stainless steel	Опора подшипника	Нержав. сталь	Supporto cuscinetto	Acciaio inox
3	Impeller	Stainless steel	Раб. колесо	Нержав. сталь	Girante	Acciaio inox
5	Suction casing	Stainless steel	Корпус всасывающей части	Нержав. сталь	Corpo aspirazione	Acciaio inox
6	Pump shaft	Stainless steel	Вал насоса	Нержав. сталь	Albero pompa	Acciaio inox
8	Flange bearing	Stainless steel	Фланец подшипника	Нержав. сталь	Flangia cuscinetto	Acciaio inox
10	Diffuser	Stainless steel	Диффузор	Нержав. сталь	Diffusore	Acciaio inox
13	Stage casing	Stainless steel	Кожух	Нержав. сталь	Mantello	Acciaio inox
14	Impeller wear ring	Stainless steel	Износное кольцо	Нержав. сталь	Anello sede girante	Acciaio inox
15	Drum wear ring	Stainless steel	Износное кольцо барабана	Нержав. сталь	Anello di rasamento tamburo	Acciaio inox
17	Tie rod	Stainless steel	Стяжка	Нержав. сталь	Tirante	Acciaio inox
18	Shaft sleeve	Stainless steel	Втулка вала	Нержав. сталь	Bussola albero	Acciaio inox
30	V seal ring	Rubber	Уплотнит. кольцо V	Резина	Anello di tenuta V	Gomma
32	Bearing	Stainless steel	Подшипник	Нержав. сталь	Cuscinetto	Acciaio inox
43	OR Seal ring	Rubber	Уплотнит. кольцо OR	Резина	Anello di tenuta OR	Gomma
72	Flange for mechanical seal	Stainless steel	Несущий фланец мех. уплотнения	Нержав. сталь	Flangia porta tenuta meccanica	Acciaio inox
79	Mechanical seal	Silicon carbide/ graphite	Мех. уплотнение	Карбид кремния/ графит	Tenuta meccanica	Carburo di silicio/ grafite

Screws and nuts in stainless steel.

Винты и гайки из нержавеющей стали.

Viti e dadi in acciaio inox.

Utilization field Область применения Campo di utilizzo ≥ 60% η		
Stage number: compatibly with the maximum pressure. Кол-во ступеней: совместимое с макс. давлением. Numero stadi: compatibilmente con la pressione massima di esercizio.		
Type Тип Tipo	MIN.	MAX.
PMXT	2	15
PMXST	2	15
NB. For two-stage pumps only, reduce efficiency by one point. Только для двухступенчатых насосов - снизить КПД на 1 единицу. Solamente per le pompe a due stadi, ridurre di un punto il rendimento.		

Wet moment of inertia J Момент инерции J мокрый Momento d'inerzia J bagnato $J = \frac{1}{4}PD^2$ - [kg m ²]		
Impeller type Тип раб. колеса Girante tipo	PMX(S)T50/1	For each additional stage Для каждой доп. ступени Per ogni stadio in più
Stainless steel Нержав. сталь Acciaio inox	0,0107	0,0095

Maximum permissible power Макс. допустимая мощность Massime potenze ammissibili	
Type Тип Tipo	N/n MAX.
PMXT	0,055
PMXST	0,055
For seal limits and calculation formulas of the maximum permissible powers, see technical data section. Ограничения по уплотнениям и формулы расчета макс. допустимой мощности - см. раздел "Технические данные". Per i limiti tenete e le formule di calcolo delle massime potenze ammissibili, vedere sezione dati tecnici.	

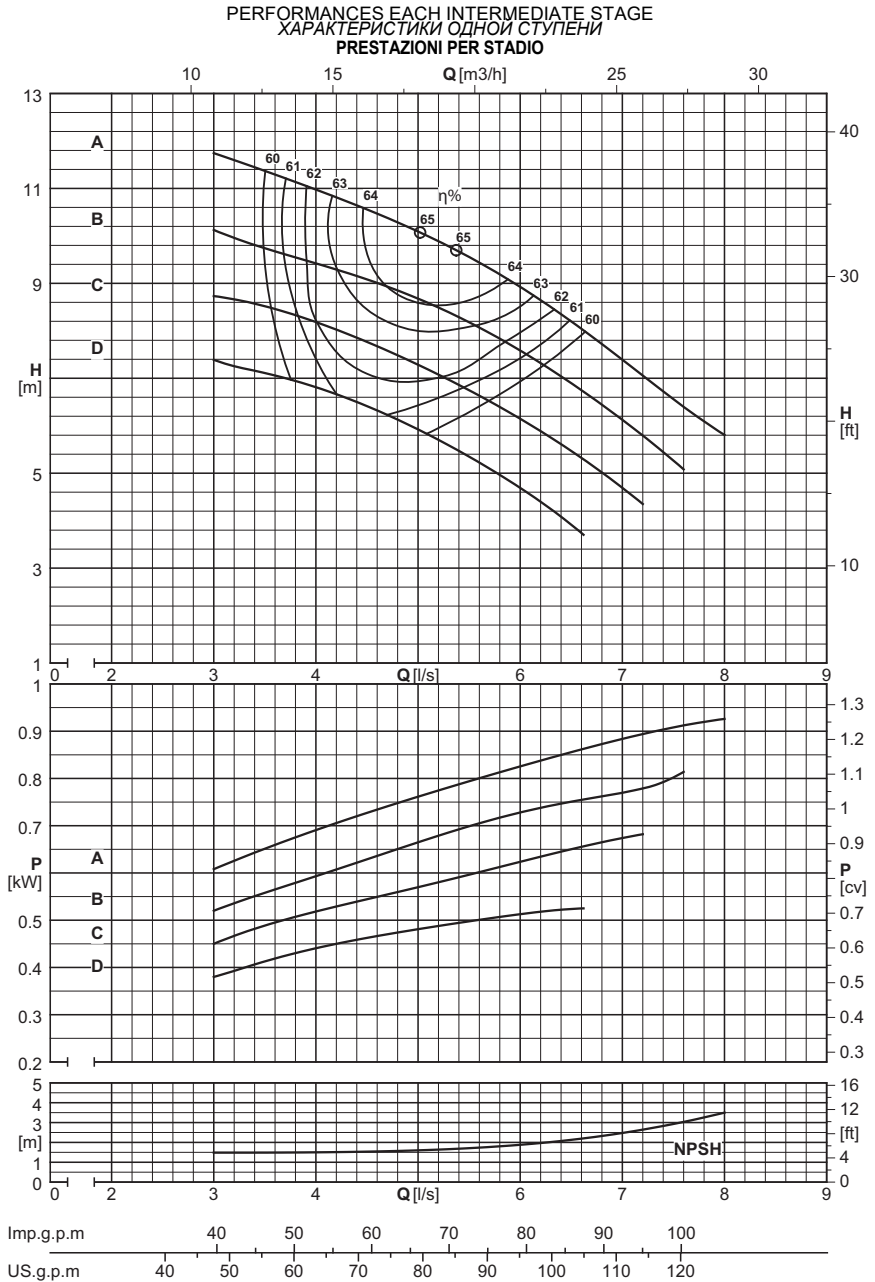

		Capacity - Расход - Portata																								
Dna x DNm	Impeller type Тип раб. кол. Girante tipo	[l/s]	0	3	3,5	4	4,5	5	5,5	6	6,5	7	7,5													
		[m³/h]	0	10,8	12,6	14,4	16,2	18	19,8	21,6	23,4	25,2	27													
		[l/min]	0	180	210	240	270	300	330	360	390	420	450													
PMX(S)T50/1																										
65x50	D	[m]	6,8	7,4	7,2	6,8	6,4	5,9	5,4																	
65x50	D	[kW]		0,4	0,4	0,4	0,5	0,5	0,5																	
65x50	C	[m]	8	8,7	8,4	8,3	7,8	7,3	6,7	6,1																
65x50	C	[kW]		0,4	0,5	0,5	0,5	0,6	0,6	0,6																
65x50	B	[m]	9,3	10	9,7	9,4	9	8,6	8,1	7,6	6,9															
65x50	B	[kW]		0,5	0,6	0,6	0,6	0,7	0,7	0,7	0,8															
65x50	A	[m]	11,5		11,5	11	10,5	10	9,5	8,9	8,2	7,4														
65x50	A	[kW]			0,6	0,7	0,7	0,8	0,8	0,8	0,9	0,9														
NPSH																										
		[m]		1,5	1,5	1,5	1,5	1,6	1,7	1,9	2,1	2,5	2,9													

Utilization field Область применения Campo di utilizzo ≥ 60% η		
Stage number: compatibly with the maximum pressure. Кол-во ступеней: совместимое с макс. давлением. Numero stadi: compatibilmente con la pressione massima di esercizio.		
Type Тип Tipo	MIN.	MAX.
PMXT	2	15
PMXST	2	15
NB. For two-stage pumps only, reduce efficiency by one point. Только для двухступенчатых насосов - снизить КПД на 1 единицу. Solamente per le pompe a due stadi, ridurre di un punto il rendimento.		

Wet moment of inertia J Момент инерции J мокрый Momento d'inerzia J bagnato J=1/4PD ² - [kg m ²]		
Impeller type Тип раб. колеса Girante tipo	PMX(S)T50/1	For each additional stage Для каждой доп. ступени Per ogni stadio in più
Stainless steel Нержав. сталь Acciaio inox	0,0107	0,0095

Maximum permissible power Макс. допустимая мощность Massime potenze ammissibili	
Type Тип Tipo	N/n MAX.
PMXT	0,055
PMXST	0,055
For seal limits and calculation formulas of the maximum permissible powers, see technical data section. Ограничения по уплотнениям и формулы расчета макс. допустимой мощности - см. раздел "Технические данные". Per i limiti tenute e le formule di calcolo delle massime potenze ammissibili, vedere sezione dati tecnici.	

PERFORMANCES EACH INTERMEDIATE STAGE
ХАРАКТЕРИСТИКИ ОДНОЙ СТУПЕНИ
PRESTAZIONI PER STADIO

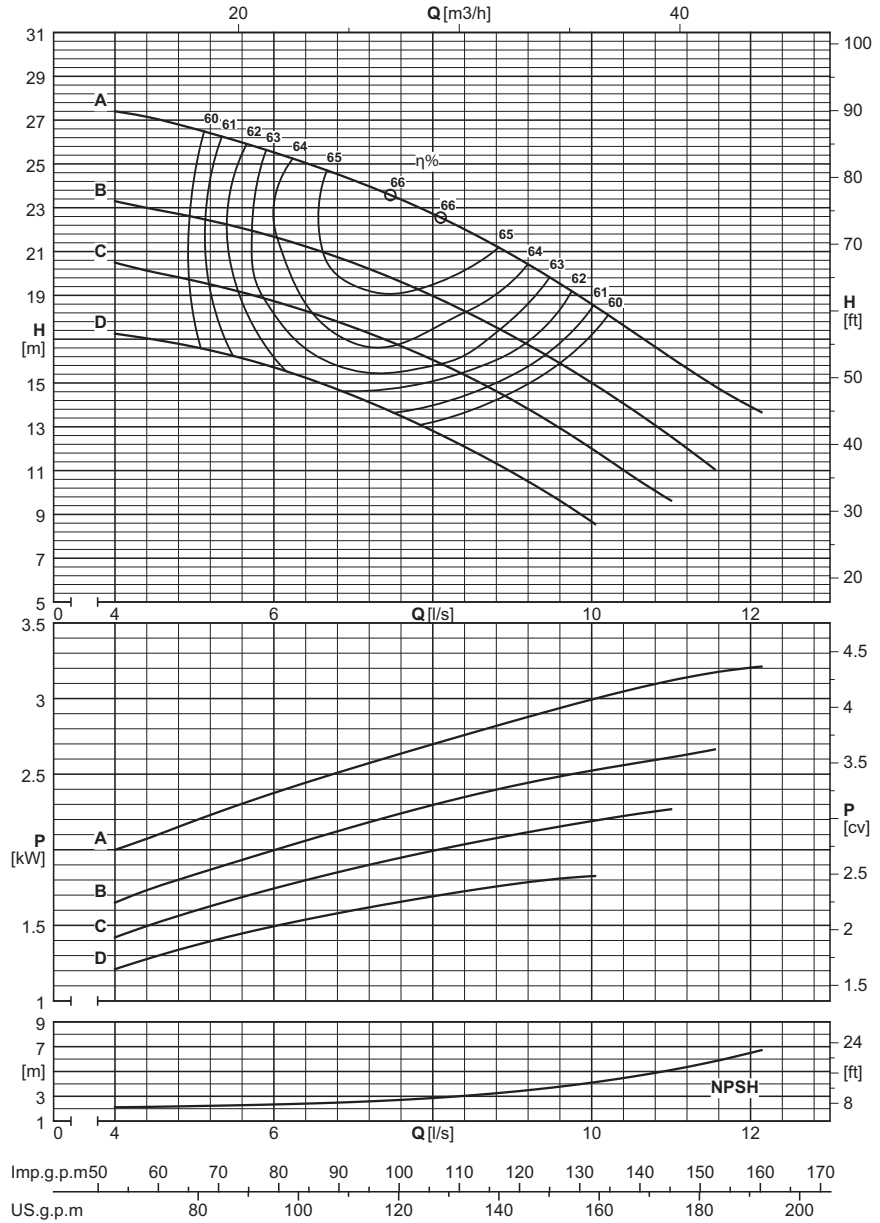

Dna x Dnm	Impeller type Тип раб. кол. Girante tipo	Capacity - Расход - Portata																	
		[l/s]	0	5	5,5	6	6,5	7	7,5	8	8,5	9	9,5	10	10,5				
		[m³/h]	0	18	19,8	21,6	23,4	25,2	27	28,8	30,6	32,4	34,2	36	37,8				
		[l/min]	0	300	330	360	390	420	450	480	510	540	570	600	630				
PMX(S)T50/1																			
65x50	D	[m]	15,5	16,5	16,5	15,5	15	14,5	13,5	13	12								
65x50	D	[kW]		1,4	1,4	1,5	1,5	1,6	1,6	1,7	1,7								
65x50	C	[m]	18	20	19	18,5	18,5	17,5	16,5	16	15	14	13						
65x50	C	[kW]		1,6	1,7	1,8	1,8	1,9	2	2	2,1	2,1	2,1						
65x50	B	[m]	21	23,5	22,5	21,5	21	21	20	20	18	17	16	15,5					
65x50	B	[kW]		1,8	1,9	2	2,1	2,1	2,2	2,3	2,4	2,4	2,5	2,5					
65x50	A	[m]	26,5	26,5	27	26,5	25	24,5	23,5	22,5	22	21	19,5	18,5	17,5				
65x50	A	[kW]		2,2	2,2	2,3	2,4	2,5	2,6	2,7	2,7	2,8	2,9	3	3,1				
NPSH																			
		[m]		2,2	2,3	2,3	2,4	2,5	2,7	2,9	3,1	3,4	3,7	4,1	4,5				

Utilization field Область применения Campo di utilizzo ≥ 60% η		
Stage number: compatibly with the maximum pressure. Кол-во ступеней: совместимое с макс. давлением. Numero stadi: compatibilmente con la pressione massima di esercizio.		
Type Тип Tipo	MIN.	MAX.
PMXT	2	15
PMXST	2	15
NB. For two-stage pumps only, reduce efficiency by one point. Только для двухступенчатых насосов - снизить КПД на 1 единицу. Solamente per le pompe a due stadi, ridurre di un punto il rendimento.		

Wet moment of inertia J Момент инерции J мокрый Momento d'inerzia J bagnato $J = \frac{1}{4}PD^2$ - [kg m ²]		
Impeller type Тип раб. колеса Girante tipo	PMX(S)T50/1	For each additional stage Для каждой доп. ступени Per ogni stadio in più
Stainless steel Нержав. сталь Acciaio inox	0,0107	0,0095

Maximum permissible power Макс. допустимая мощность Massime potenze ammissibili	
Type Тип Tipo	N/n MAX.
PMXT	0,055
PMXST	0,055
For seal limits and calculation formulas of the maximum permissible powers, see technical data section. Ограничения по уплотнениям и формулы расчета макс. допустимой мощности - см. раздел "Технические данные". Per i limiti tenete e le formule di calcolo delle massime potenze ammissibili, vedere sezione dati tecnici.	

PERFORMANCES EACH INTERMEDIATE STAGE
ХАРАКТЕРИСТИКИ ОДНОЙ СТУПЕНИ
PRESTAZIONI PER STADIO

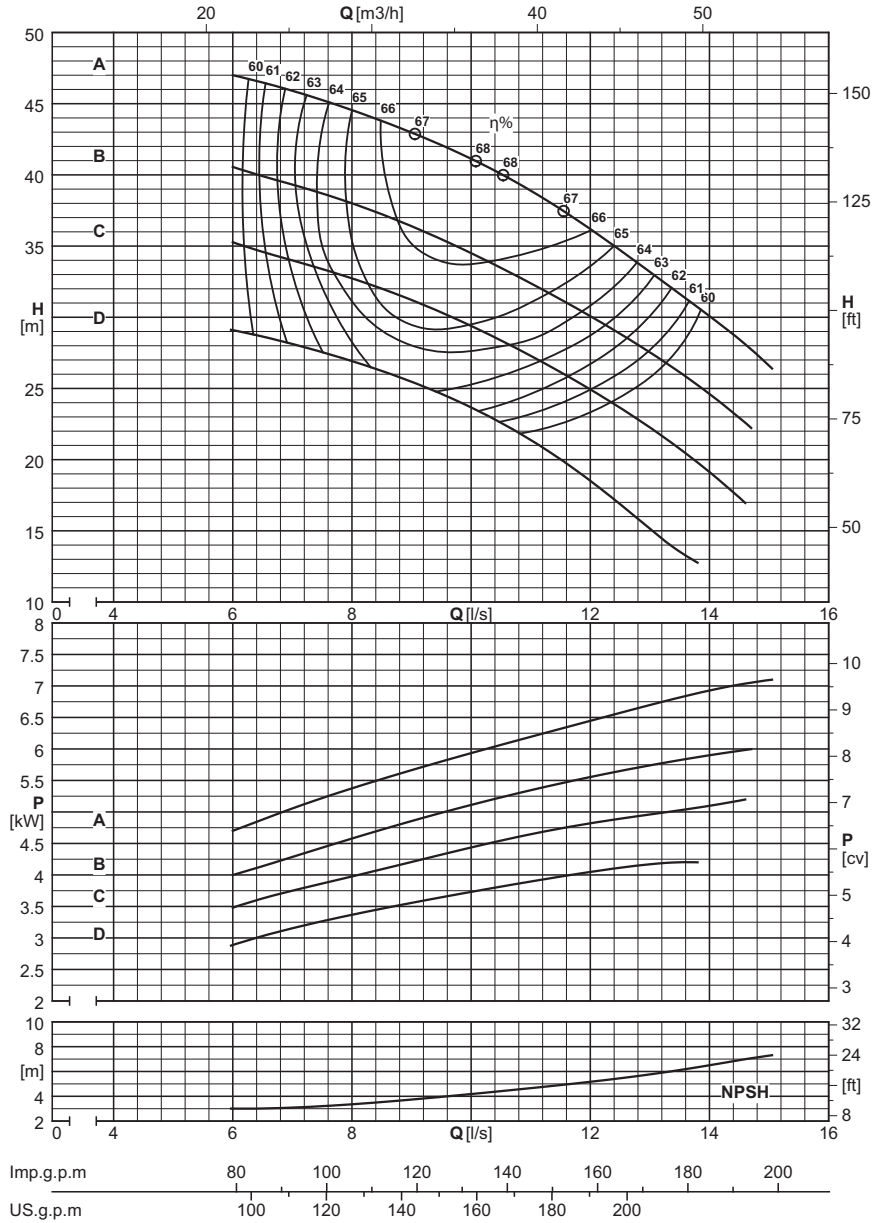

		Capacity - Расход - Portata																			
Dna x DNm	Impeller type Тип раб. кол. Girante tipo	[l/s]	0	6	6,5	7	7,5	8	8,5	9	9,5	10	10,5	11	11,5	12	12,5	13	13,5	14	
		[m³/h]	0	21,6	23,4	25,2	27	28,8	30,6	32,4	34,2	36	37,8	39,6	41,4	43,2	45	46,8	48,6	50,4	
		[l/min]	0	360	390	420	450	480	510	540	570	600	630	660	690	720	750	780	810	840	
PMX(S)T50/1																					
65x50	D	[m]	27,5	30	28	27,5	28	27,5	26	25,5	24,5	23,5	22,5	21,5	20						
65x50	D	[kW]		2,9	3,1	3,2	3,2	3,4	3,5	3,6	3,6	3,7	3,8	3,9	4						
65x50	C	[m]	32	35,5	34,5	33,5	33	32	32,5	31,5	30,5	29,5	28,5	27,5	26	25,5	24	22,5			
65x50	C	[kW]		3,5	3,6	3,8	3,9	4	4	4,2	4,3	4,4	4,5	4,7	4,8	4,8	4,9	5			
65x50	B	[m]	37,5	40,5	39,5	39	38	37,5	36,5	37	36	34,5	33,5	32,5	31,5	30	29	27,5	26,5	25	
65x50	B	[kW]		4	4,2	4,3	4,5	4,6	4,8	4,8	4,9	5,1	5,2	5,3	5,5	5,6	5,7	5,8	5,9	6	
65x50	A	[m]	46,5	47,5	46,5	45,5	45	44	43,5	42,5	41,5	40,5	39,5	38,5	37,5	36	34,5	33	31,5	30	
65x50	A	[kW]		4,7	4,9	5,1	5,2	5,4	5,6	5,7	5,9	6	6,1	6,3	6,3	6,4	6,5	6,7	6,8	6,9	
NPSH																					
		[m]		3	3	3,1	3,2	3,4	3,5	3,7	4	4,2	4,4	4,7	4,9	5,2	5,5	5,8	6,1	6,5	

Utilization field Область применения Campo di utilizzo ≥ 60% η		
Stage number: compatibly with the maximum pressure. Кол-во ступеней: совместимое с макс. давлением. Numero stadi: compatibilmente con la pressione massima di esercizio.		
Type Тип Tipo	MIN.	MAX.
PMXT	2	12
PMXST	2	12
NB. For two-stage pumps only, reduce efficiency by one point. Только для двухступенчатых насосов - снизить КПД на 1 единицу. Solamente per le pompe a due stadi, ridurre di un punto il rendimento.		

Wet moment of inertia J Момент инерции J мокрый Momento d'inerzia J bagnato $J = \frac{1}{2}PD^2$ - [kg m ²]		
Impeller type Тип раб. колеса Girante tipo	PMX(S)T50/1	For each additional stage Для каждой доп. ступени Per ogni stadio in più
Stainless steel Нержав. сталь Acciaio inox	0,0107	0,0095

Maximum permissible power Макс. допустимая мощность Massime potenze ammissibili	
Type Тип Tipo	N/n MAX.
PMXT	0,055
PMXST	0,055
For seal limits and calculation formulas of the maximum permissible powers, see technical data section. Ограничения по уплотнениям и формулы расчета макс. допустимой мощности - см. раздел "Технические данные". Per i limiti tenute e le formule di calcolo delle massime potenze ammissibili, vedere sezione dati tecnici.	

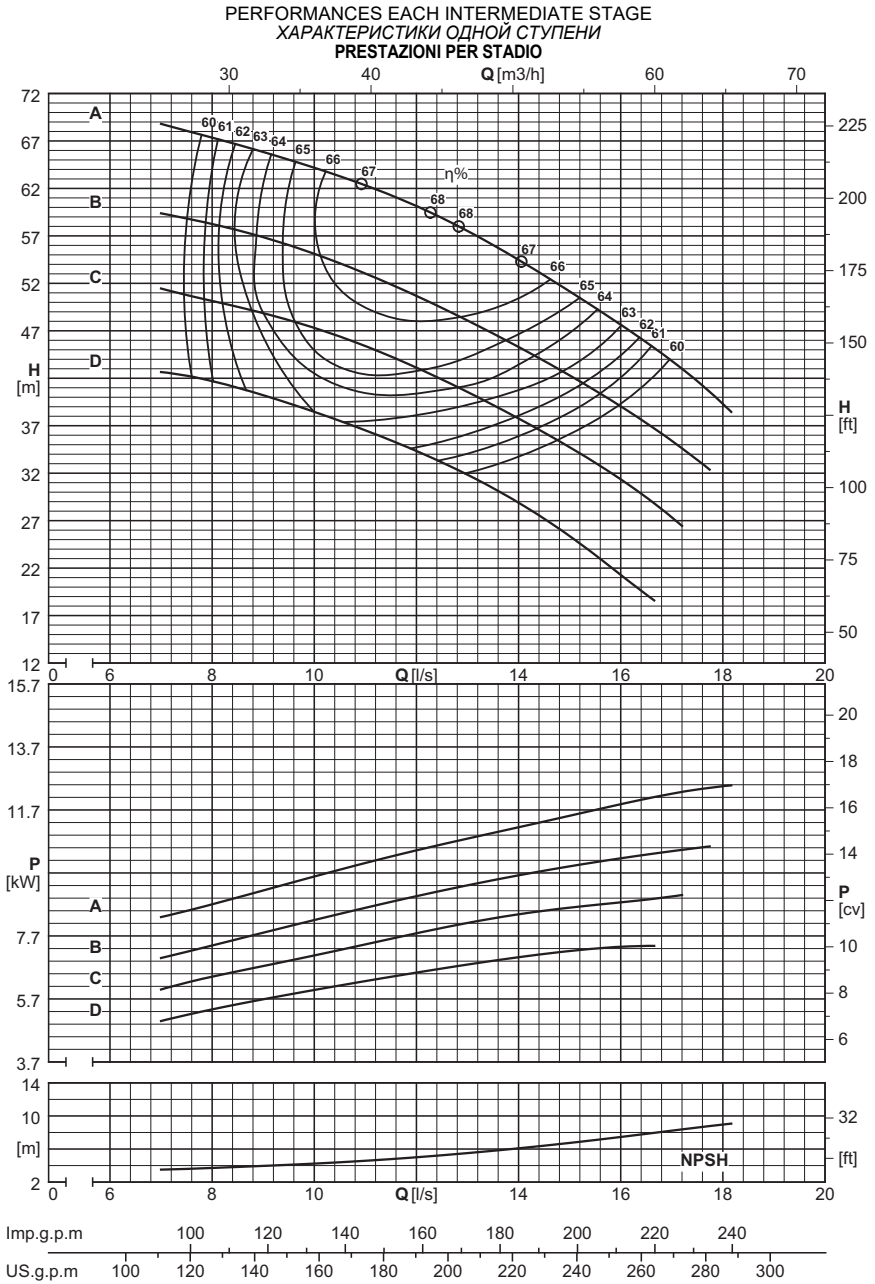

Dna x Dnm	Impeller type Тип раб. кол. Girante tipo	Capacity - Расход - Portata																						
		[l/s]	0	7,5	8	8,5	9	9,5	10	10,5	11	11,5	12	12,5	13	13,5	14	14,5	15	15,5	16	16,5	17	
		[m³/h]	0	27	28,8	30,6	32,4	34,2	36	37,8	39,6	41,4	43,2	45	46,8	48,6	50,4	52,2	54	55,8	57,6	59,4	61,2	
		[l/min]	0	450	480	510	540	570	600	630	660	690	720	750	780	810	840	870	900	930	960	990	1020	

		PMX(S)T50/1																						
65x50	D	[m]	40	42,5	42	41	40,5	39,5	38,5	37,5	36,5	35,5	34,5	33	32	30,5								
65x50	D	[kW]		5,2	5,4	5,5	5,7	5,8	6	6,1	6,2	6,4	6,5	6,6	6,8	6,9								
65x50	C	[m]	46,5	51	50	50	49,5	49	48	47,5	45	44,5	43	42	40,5	39	38	36,5	34,5	33,5				
65x50	C	[kW]		6,2	6,4	6,5	6,7	6,8	7	7,2	7,5	7,7	7,8	8	8,1	8,3	8,4	8,5	8,6	8,6				
65x50	B	[m]	54	59	59	58	58	55	54	53	52	51	50	49,5	48,5	46,5	45	44	42,5	40,5	40	37		
65x50	B	[kW]		7,2	7,3	7,5	7,7	8,1	8,3	8,4	8,6	8,8	8,9	9,1	9,2	9,6	9,7	9,8	9,9	10	10,1	10,2		
65x50	A	[m]	67	68	68	68	64	64	63	63	62	61	60	58	57	56	54	52	51	49,5	47,5	46	44	
65x50	A	[kW]		8,4	8,6	8,8	9,3	9,4	9,6	9,8	10	10,1	10,3	10,7	10,8	11	11,1	11,3	11,4	11,8	12	12,1	12,2	

		NPSH																					
	[m]		3,6	3,7	3,8	4	4,1	4,2	4,4	4,6	4,8	5	5,3	5,5	5,8	6,1	6,4	6,8	7,1	7,5	7,8	8,2	

Overall dimensions and weights
 Общие габариты и вес
 Dimensioni di ingombro e pesi

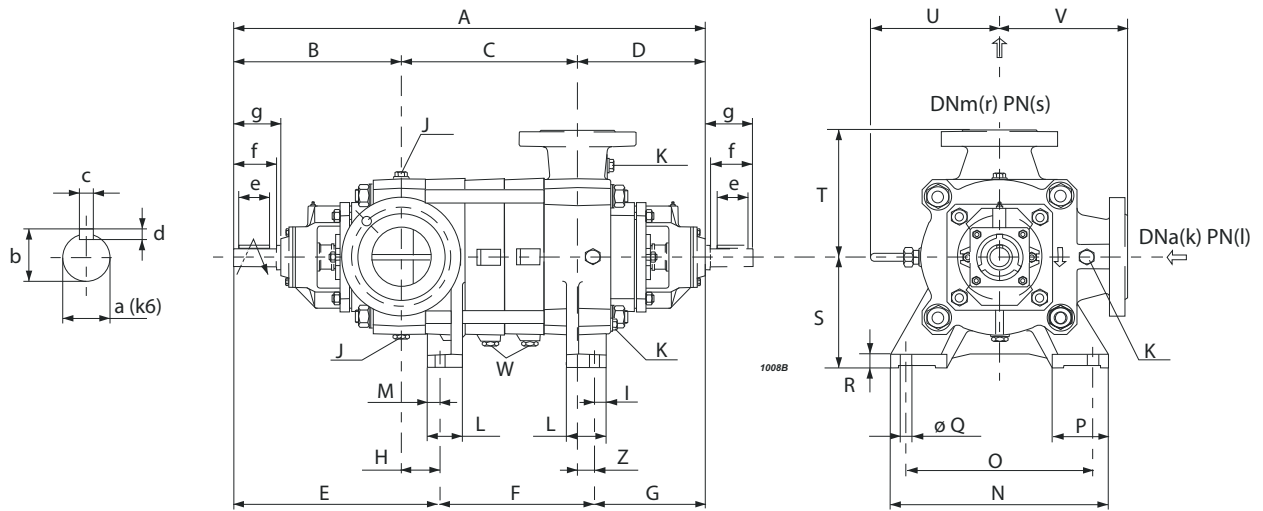

Series Серия Serie	Type Тип Tipo	A	B	C	D	E	F	G	H	S	T	U	V	Z	Weight Bec Peso
		[mm]													[kg]
PMX(S)T	50/2	653	289	137	227	356	100	197	67	180	195	232	195	30	108
PMX(S)T	50/3	713	289	197	227	356	160	197	67	180	195	232	195	30	121
PMX(S)T	50/4	773	289	257	227	356	220	197	67	180	195	232	195	30	134
PMX(S)T	50/5	833	289	317	227	356	280	197	67	180	195	232	195	30	148
PMX(S)T	50/6	893	289	377	227	356	340	197	67	180	195	232	195	30	161
PMX(S)T	50/7	953	289	437	227	356	400	197	67	180	195	232	195	30	174
PMX(S)T	50/8	1013	289	497	227	356	460	197	67	180	195	232	195	30	187
PMX(S)T	50/9	1073	289	557	227	356	520	197	67	180	195	232	195	30	200
PMX(S)T	50/10	1133	289	617	227	356	580	197	67	180	195	232	195	30	213
PMX(S)T	50/11	1193	289	677	227	356	640	197	67	180	195	232	195	30	226
PMX(S)T	50/12	1253	289	737	227	356	700	197	67	180	195	232	195	30	239
PMX(S)T	50/13	1313	289	797	227	356	760	197	67	180	195	232	195	30	252
PMX(S)T	50/14	1373	289	857	227	356	820	197	67	180	195	232	195	30	265
PMX(S)T	50/15	1433	289	917	227	356	880	197	67	180	195	232	195	30	278

Foot dimensions Размеры ножек Dimensioni dei piedi							
I	L	M	N	O	P	Q	R
[mm]							
43	60	40	370	320	90	18	23

Shaft projection Выступ вала Sporgenza d'albero							
a	b	c	d	e	f	g	
[mm]							
27	30	8	7	55	70	79,5	

Type Тип Tipo	Flanges Фланцы Flange			
	(k) DNa	(l) PN	(r) DNm	(s) PN
	[mm]	[bar]	[mm]	[bar]
PMXT	65	25	50	40
PMXST	65	25	50	63

Plugs Пробки Tappi		
J	K	W
G 1/2	G3/8	G 1/4

Selection - dimensions and weights for base mounted electric pumps
 Подбор - габариты и вес электронасосов на раме
 Selezione - dimensioni e pesi elettropompe su base

COUPLINGS WITH STANDARDIZED ENCLOSED ELECTRIC MOTORS
 СОЕДИНЕНИЕ С НОРМАЛИЗОВАННЫМИ ЗАКРЫТЫМИ ЭЛЕКТРОДВИГАТЕЛЯМИ
 ACCORPIAMENTI CON MOTORI ELETTRICI CHIUSI NORMALIZZATI

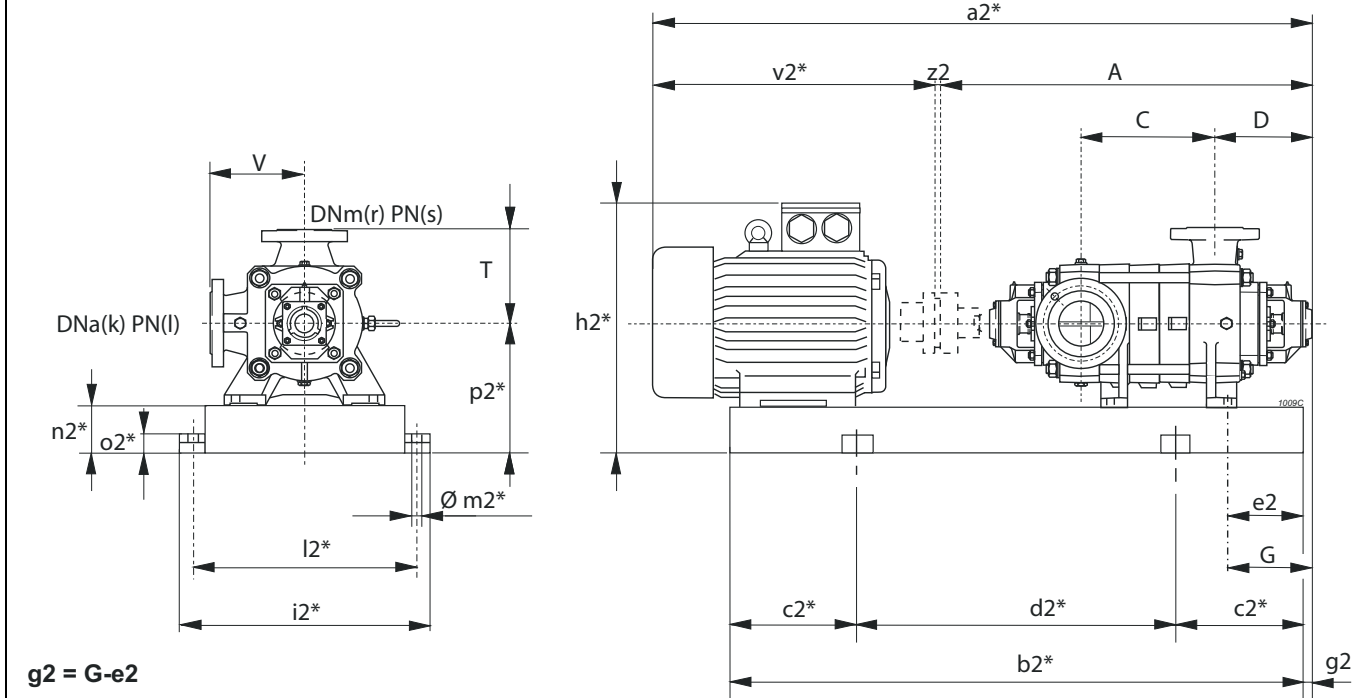

$g2 = G - e2$

* Valori indicativi in funzione della marca di motore utilizzato
 Indicatives values according to the type of motor installed

Приблизительные значения в зависимости от марки двигателя.

Pump Насос Pompa	Motor Двигатель Motore	BGAM	A	C	D	G	T	V	a2*	b2*	c2*	d2*	e2	h2*	i2*	k	l	l2*	m2*	n2*	o2*	p2*	r	s	v2*	z2	Weight Вес Peso		
Series Серия Serie	Type Тип Tipo	[kW]	Size Размер Grand.	Type Тип Tipo	[mm]																							[kg]	
PMX(S)T	50/2	11	160M	876/DM	652,5	137	227	197	195	195	1283,5	993	150	693	40	531	500	65	25	450	20	100	42	280	50	(2)	627	4	267
PMX(S)T	/2	15	160M	876/DM	652,5	137	227	197	195	195	1283,5	993	150	693	40	531	500	65	25	450	20	100	42	280	50	(2)	627	4	278
PMX(S)T	50/3	15	160M	877/DM	712,5	197	227	197	195	195	1343,5	1053	200	693	40	531	500	65	25	450	20	100	42	280	50	(2)	627	4	291
PMX(S)T	/3	18,5	160L	878/DM	712,5	197	227	197	195	195	1343,5	1097	200	697	40	531	500	65	25	450	20	100	42	280	50	(2)	627	4	304
PMX(S)T	/3	22	180M	879/EM	712,5	197	227	197	195	195	1381,5	1107	200	707	40	550	500	65	25	450	20	100	42	280	50	(2)	665	4	344
PMX(S)T	50/4	18,5	160L	880/DM	772,5	257	227	197	195	195	1403,5	1157	200	757	40	531	500	65	25	450	20	100	42	280	50	(2)	627	4	317
PMX(S)T	/4	22	180M	881/EM	772,5	257	227	197	195	195	1441,5	1167	200	767	40	550	500	65	25	450	20	100	42	280	50	(2)	665	4	357
PMX(S)T	/4	30	200L	882/FM	772,5	257	227	197	195	195	1514,5	1260	200	860	60	600	540	65	25	490	20	100	42	300	50	(2)	738	4	419
PMX(S)T	50/5	22	180M	883/EM	832,5	317	227	197	195	195	1501,5	1227	200	827	40	550	500	65	25	450	20	100	42	280	50	(2)	665	4	370
PMX(S)T	/5	30	200L	884/FM	832,5	317	227	197	195	195	1574,5	1320	200	920	60	600	540	65	25	490	20	100	42	300	50	(2)	738	4	432
PMX(S)T	/5	37	200L	884/FM	832,5	317	227	197	195	195	1574,5	1320	200	920	60	600	540	65	25	490	20	100	42	300	50	(2)	738	4	460
PMX(S)T	50/6	30	200L	885/FM	892,5	377	227	197	195	195	1634,5	1380	250	880	60	600	540	65	25	490	20	100	42	300	50	(2)	738	4	445
PMX(S)T	/6	37	200L	885/FM	892,5	377	227	197	195	195	1634,5	1380	250	880	60	600	540	65	25	490	20	100	42	300	50	(2)	738	4	473
PMX(S)T	/6	45	225M	886/FM	892,5	377	227	197	195	195	1671,5	1416	250	916	70	675	585	65	25	535	20	120	42	345	50	(2)	775	4	549
PMX(S)T	50/7	30	200L	887/FM	952,5	437	227	197	195	195	1694,5	1440	250	940	60	600	540	65	25	490	20	100	42	300	50	(2)	738	4	459
PMX(S)T	/7	37	200L	887/FM	952,5	437	227	197	195	195	1694,5	1440	250	940	60	600	540	65	25	490	20	100	42	300	50	(2)	738	4	487
PMX(S)T	/7	45	225M	888/FM	952,5	437	227	197	195	195	1731,5	1476	250	976	70	675	585	65	25	535	20	120	42	345	50	(2)	775	4	563
PMX(S)T	/7	55	250M	889/GM	952,5	437	227	197	195	195	1826,5	1558	250	1058	80	745	635	65	25	585	20	120	42	370	50	(2)	870	4	673
PMX(S)T	50/8	37	200L	890/FM	1012,5	497	227	197	195	195	1754,5	1500	250	1000	60	600	540	65	25	490	20	100	42	300	50	(2)	738	4	500
PMX(S)T	/8	45	225M	891/FM	1012,5	497	227	197	195	195	1791,5	1536	250	1036	70	675	585	65	25	535	20	120	42	345	50	(2)	775	4	576
PMX(S)T	/8	55	250M	892/GM	1012,5	497	227	197	195	195	1886,5	1618	250	1118	80	745	635	65	25	585	20	120	42	370	50	(2)	870	4	686
PMX(S)T	/8	75	280S	893/HM	1012,5	497	227	197	195	195	2016,5	1675	300	1075	90	815	695	65	25	645	20	140	42	420	50	(2)	1000	4	917
PMX(S)T	50/9	45	225M	894/FM	1072,5	557	227	197	195	195	1851,5	1596	250	1096	70	675	585	65	25	535	20	120	42	345	50	(2)	775	4	590
PMX(S)T	/9	55	250M	895/GM	1072,5	557	227	197	195	195	1946,5	1678	300	1078	80	745	635	65	25	585	20	120	42	370	50	(2)	870	4	700
PMX(S)T	/9	75	280S	896/HM	1072,5	557	227	197	195	195	2076,5	1735	300	1135	90	815	695	65	25	645	20	140	42	420	50	(2)	1000	4	931
PMX(S)T	50/10	45	225M	897/FM	1132,5	617	227	197	195	195	1911,5	1656	300	1056	70	675	585	65	25	535	20	120	42	345	50	(2)	775	4	604
PMX(S)T	/10	55	250M	898/GM	1132,5	617	227	197	195	195	2006,5	1738	300	1138	80	745	635	65	25	585	20	120	42	370	50	(2)	870	4	713
PMX(S)T	/10	75	280S	899/HM	1132,5	617	227	197	195	195	2136,5	1795	300	1195	90	815	695	65	25	645	20	140	42	420	50	(2)	1000	4	945
PMX(S)T	/10	90	280M	900/HM	1132,5	617	227	197	195	195	2187,5	1846	300	1246	90	815	695	65	25	645	20	140	42	420	50	(2)	1051	4	1074

BGAM = Base and coupling

* = Indicatives values according to the type of motor installed.

○ Motor in IE4 efficiency class according to EU REGULATION 2019/1781. Available in other efficiency classes for non-EU markets.

(2) PMXT=40 bar PMXST=63 bar

BGAM = Рама и муфта

* = Приблизит. значения в завис. от марки двигателя.

○ Двигатель класса эффективности IE4 в соответствии с РЕГЛАМЕНТОМ ЕС 2019/1781. Доступны другие классы эффективности для рынков за пределами ЕС.

(2) PMXT=40 бар PMXST=63 бар

BGAM = Base giunto e coprigiunto

* = Valori indicativi in funzione della marca di motore utilizzato.

○ Motore in classe di efficienza IE4 in conformità al REGOLAMENTO UE2019/1781. Disponibili in altre classi di efficienza per mercati extra UE.

(2) PMXT=40 bar PMXST=63 bar

Selection - dimensions and weights for base mounted electric pumps
 Подбор - габариты и вес электронасосов на раме
 Selezione - dimensioni e pesi elettropompe su base

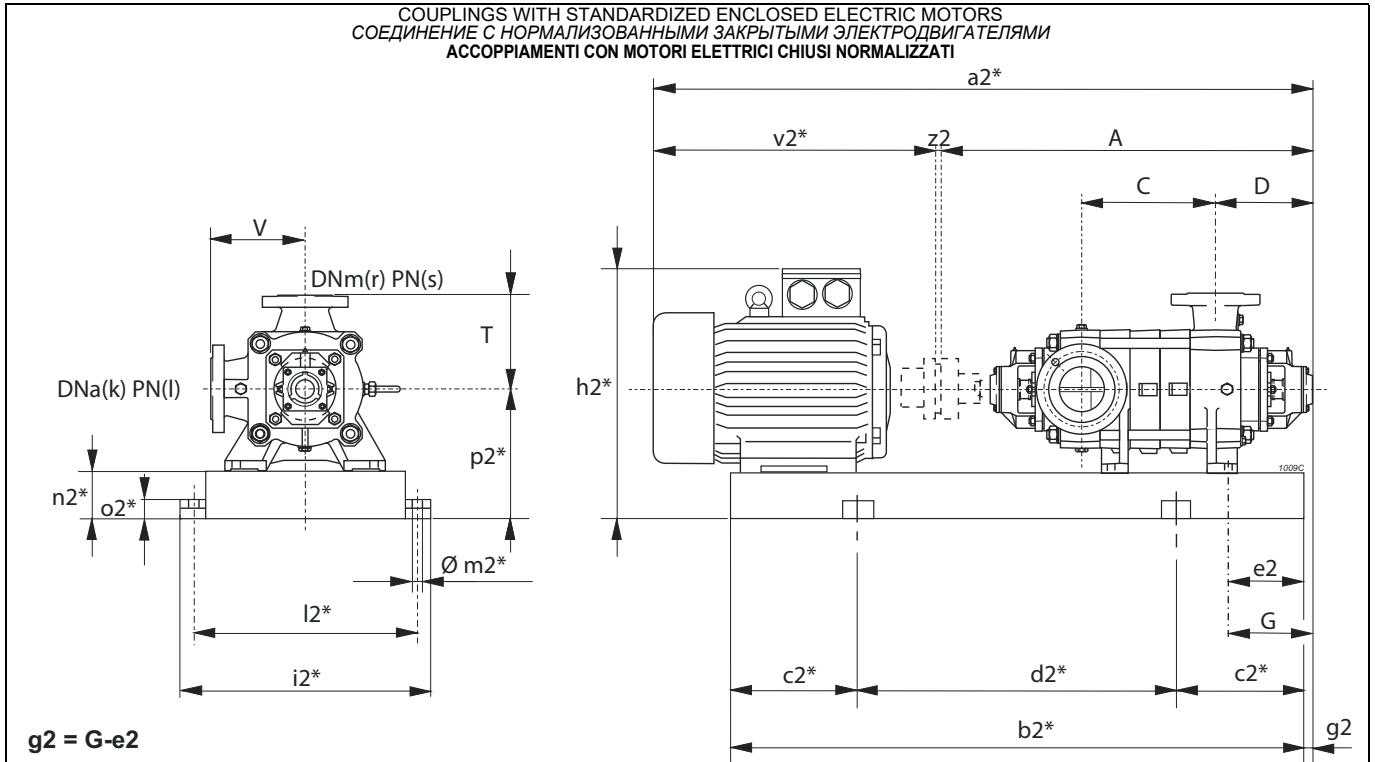

* Valori indicativi in funzione della marca di motore utilizzato
 Indicatives values according to the type of motor installed

Приблизительные значения в зависимости от марки двигателя.

Pump Насос Pompa	Motor Двигатель Motore	BGAM	A	C	D	G	T	V	a2*	b2*	c2*	d2*	e2	h2*	i2*	k	l	l2*	m2*	n2*	o2*	p2*	r	s	v2*	z2	Weight Вес Peso		
Series Серия Serie	Type Тип Tipo	[kW]	Size Размер Grand.	Type Тип Tipo	[mm]																				[kg]				
PMX(S)T	50/11	55	250M	901/GM	1192,5	677	227	197	195	195	2066,5	1798	300	1198	80	745	635	65	25	585	20	120	42	370	50	(2)	870	4	727
PMX(S)T	/11	75	280S	902/HM	1192,5	677	227	197	195	195	2196,5	1855	300	1255	90	815	695	65	25	645	20	140	42	420	50	(2)	1000	4	959
PMX(S)T	/11	90	280M	903/HM	1192,5	677	227	197	195	195	2247,5	1906	300	1306	90	815	695	65	25	645	20	140	42	420	50	(2)	1051	4	1087
PMX(S)T	50/12	55	250M	904/GM	1252,5	737	227	197	195	195	2126,5	1858	300	1258	80	745	635	65	25	585	20	120	42	370	50	(2)	870	4	741
PMX(S)T	/12	75	280S	905/HM	1252,5	737	227	197	195	195	2256,5	1915	300	1315	90	815	695	65	25	645	20	140	42	420	50	(2)	1000	4	973
PMX(S)T	/12	90	280M	906/HM	1252,5	737	227	197	195	195	2307,5	1966	350	1266	90	815	695	65	25	645	20	140	42	420	50	(2)	1051	4	1101
PMX(S)T	/12	110	315S	907/IM	1252,5	737	227	197	195	195	2437,5	2022	350	1322	100	1030	780	65	25	730	22	160	50	475	50	(2)	1181	4	1378
PMX(S)T	50/13	75	280S	908/HM	1312,5	797	227	197	195	195	2316,5	1975	350	1275	90	815	695	65	25	645	20	140	42	420	50	(2)	1000	4	987
PMX(S)T	/13	90	280M	909/HM	1312,5	797	227	197	195	195	2367,5	2026	350	1326	90	815	695	65	25	645	20	140	42	420	50	(2)	1051	4	1115
PMX(S)T	/13	110	315S	910/IM	1312,5	797	227	197	195	195	2497,5	2082	350	1382	100	1030	780	65	25	730	22	160	50	475	50	(2)	1181	4	1392
PMX(S)T	50/14	75	280S	911/HM	1372,5	857	227	197	195	195	2376,5	2035	350	1335	90	815	695	65	25	645	20	140	42	420	50	(2)	1000	4	1001
PMX(S)T	/14	90	280M	912/HM	1372,5	857	227	197	195	195	2427,5	2086	350	1386	90	815	695	65	25	645	20	140	42	420	50	(2)	1051	4	1129
PMX(S)T	/14	110	315S	913/IM	1372,5	857	227	197	195	195	2557,5	2142	350	1442	100	1030	780	65	25	730	22	160	50	475	50	(2)	1181	4	1406
PMX(S)T	50/15	75	280S	9911/HM	1432,5	917	227	197	195	195	2436,5	2095	350	1395	90	815	695	65	25	645	20	140	42	420	50	(2)	1000	4	1014
PMX(S)T	/15	90	280M	9912/HM	1432,5	917	227	197	195	195	2487,5	2146	350	1446	90	815	695	65	25	645	20	140	42	420	50	(2)	1051	4	1143
PMX(S)T	/15	110	315S	914/IM	1432,5	917	227	197	195	195	2617,5	2202	350	1502	100	1030	780	65	25	730	22	160	50	475	50	(2)	1181	4	1420
PMX(S)T	/15	132	315M	9913/IM	1432,5	917	227	197	195	195	2727,5	2261	400	1461	100	1030	780	65	25	730	22	160	50	475	50	(2)	1291	4	1494

BGAM = Base and coupling
 * = Indicatives values according to the type of motor installed.

BGAM = Рама и муфта
 * = Приблизит. значения в завис. от марки двигателя.

BGAM = Base giunto e coprigiunto
 * = Valori indicativi in funzione della marca di motore utilizzato.

○ Motor in IE4 efficiency class according to EU REGULATION 2019/1781. Available in other efficiency classes for non-EU markets.

○ Двигатель класса эффективности IE4 в соответствии с РЕГЛАМЕНТОМ ЕС 2019/1781. Доступны другие классы эффективности для рынков за пределами ЕС.

○ Motore in classe di efficienza IE4 in conformità al REGOLAMENTO UE2019/1781. Disponibili in altre classi di efficienza per mercati extra UE.

(2) PMXT=40 bar PMXST=63 bar

(2) PMXT=40 бар PMXST=63 бар

(2) PMXT=40 bar PMXST=63 bar

Selection - dimensions and weights for base mounted electric pumps
 Подбор - габариты и вес электронасосов на раме
 Selezione - dimensioni e pesi elettropompe su base

COUPLINGS WITH STANDARDIZED ENCLOSED ELECTRIC MOTORS
 СОЕДИНЕНИЕ С НОРМАЛИЗОВАННЫМИ ЗАКРЫТЫМИ ЭЛЕКТРОДВИГАТЕЛЯМИ
 ACCOPPIAMENTI CON MOTORI ELETTRICI CHIUSI NORMALIZZATI

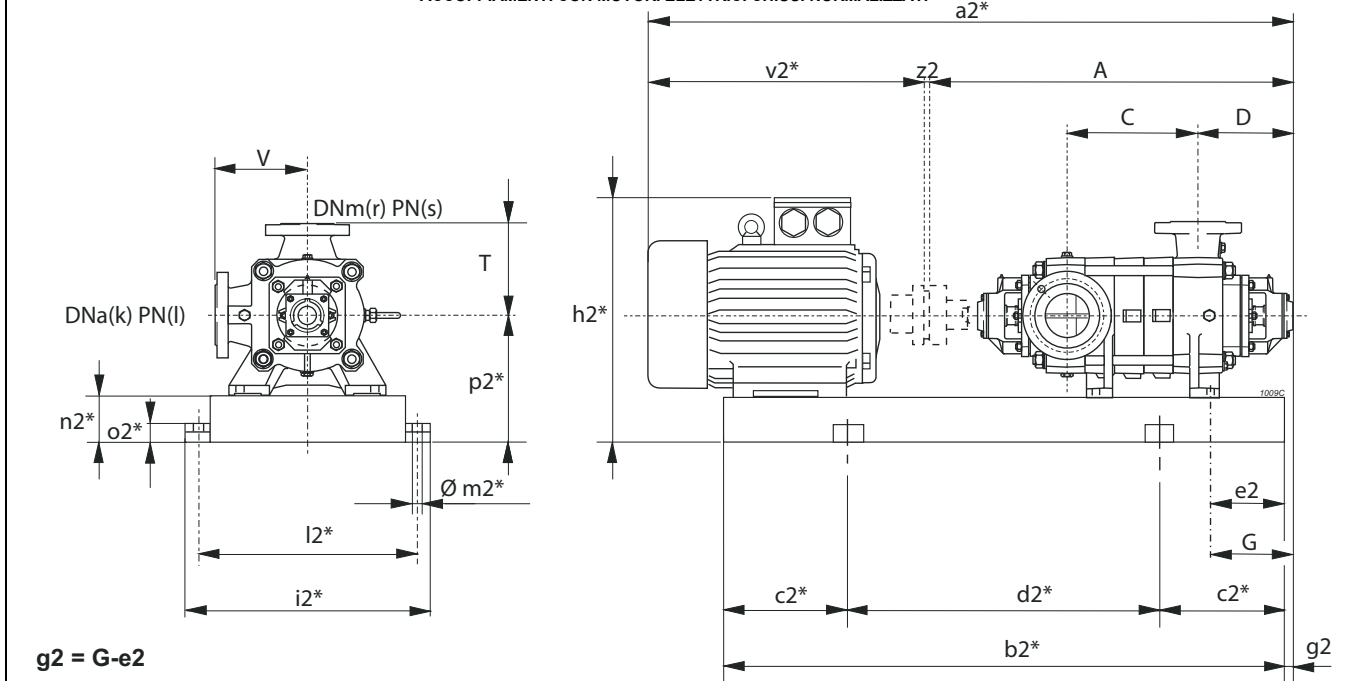

$g2 = G - e2$

* Valori indicativi in funzione della marca di motore utilizzato

Indicatives values according to the type of motor installed

Приблизительные значения в зависимости от марки двигателя.

Pump Насос Помпа	Motor Двигатель Motore	BGAM	A	C	D	G	T	V	a2*	b2*	c2*	d2*	e2	h2*	i2*	k	l	l2*	m2*	n2*	o2*	p2*	r	s	v2*	z2	Weight Вес Peso		
Series Серия Serie	Type Тип Tipo	[kW]	Size Размер Grand.	Type Тип Tipo	[mm]																				[kg]				
PMX(S)T	50/2	1,1	90S	951/CL	652,5	137	227	197	195	195	1011,5	741	100	541	40	418	500	65	25	450	20	100	42	280	50	(2)	355	4	153
PMX(S)T	/2	1,5	90L	915/CL	652,5	137	227	197	195	195	1041,5	766	150	466	40	418	500	65	25	450	20	100	42	280	50	(2)	385	4	158
PMX(S)T	/2	2,2	100L	9917/CL	652,5	137	227	197	195	195	1061,5	801	150	501	40	430	500	65	25	450	20	100	42	280	50	(2)	405	4	171
PMX(S)T	50/3	1,5	90L	916/CL	712,5	197	227	197	195	195	1101,5	826	150	526	40	418	500	65	25	450	20	100	42	280	50	(2)	385	4	171
PMX(S)T	/3	2,2	100L	917/CL	712,5	197	227	197	195	195	1121,5	861	150	561	40	430	500	65	25	450	20	100	42	280	50	(2)	405	4	184
PMX(S)T	/3	3	100L	917/CL	712,5	197	227	197	195	195	1121,5	861	150	561	40	430	500	65	25	450	20	100	42	280	50	(2)	405	4	188
PMX(S)T	50/4	2,2	100L	918/CL	772,5	257	227	197	195	195	1181,5	921	150	621	40	430	500	65	25	450	20	100	42	280	50	(2)	405	4	197
PMX(S)T	/4	3	100L	918/CL	772,5	257	227	197	195	195	1181,5	921	150	621	40	430	500	65	25	450	20	100	42	280	50	(2)	405	4	201
PMX(S)T	/4	4	112M	919/CL	772,5	257	227	197	195	195	1216,5	928	150	628	40	452	500	65	25	450	20	100	42	280	50	(2)	440	4	203
PMX(S)T	50/5	3	100L	920/CL	832,5	317	227	197	195	195	1241,5	981	150	681	40	430	500	65	25	450	20	100	42	280	50	(2)	405	4	214
PMX(S)T	/5	4	112M	921/CL	832,5	317	227	197	195	195	1276,5	988	150	688	40	452	500	65	25	450	20	100	42	280	50	(2)	440	4	216
PMX(S)T	/5	5,5	132S	922/DL	832,5	317	227	197	195	195	1291,5	1049	150	749	40	472	500	65	25	450	20	100	42	280	50	(2)	455	4	226
PMX(S)T	50/6	3	100L	923/CL	892,5	377	227	197	195	195	1301,5	1041	150	741	40	430	500	65	25	450	20	100	42	280	50	(2)	405	4	228
PMX(S)T	/6	4	112M	924/CL	892,5	377	227	197	195	195	1336,5	1048	150	748	40	452	500	65	25	450	20	100	42	280	50	(2)	440	4	229
PMX(S)T	/6	5,5	132S	925/DL	892,5	377	227	197	195	195	1351,5	1109	200	709	40	472	500	65	25	450	20	100	42	280	50	(2)	455	4	239
PMX(S)T	50/7	4	112M	926/CL	952,5	437	227	197	195	195	1396,5	1108	200	708	40	452	500	65	25	450	20	100	42	280	50	(2)	440	4	242
PMX(S)T	/7	5,5	132S	927/DL	952,5	437	227	197	195	195	1411,5	1169	200	769	40	472	500	65	25	450	20	100	42	280	50	(2)	455	4	252
PMX(S)T	/7	7,5	132M	928/DL	952,5	437	227	197	195	195	1446,5	1207	200	807	40	472	500	65	25	450	20	100	42	280	50	(2)	490	4	261
PMX(S)T	50/8	4	112M	929/CL	1012,5	497	227	197	195	195	1456,5	1168	200	768	40	452	500	65	25	450	20	100	42	280	50	(2)	440	4	256
PMX(S)T	/8	5,5	132S	930/DL	1012,5	497	227	197	195	195	1471,5	1229	200	829	40	472	500	65	25	450	20	100	42	280	50	(2)	455	4	266
PMX(S)T	/8	7,5	132M	931/DL	1012,5	497	227	197	195	195	1506,5	1267	200	867	40	472	500	65	25	450	20	100	42	280	50	(2)	490	4	274
PMX(S)T	50/9	5,5	132S	932/DL	1072,5	557	227	197	195	195	1531,5	1289	200	889	40	472	500	65	25	450	20	100	42	280	50	(2)	455	4	279
PMX(S)T	/9	7,5	132M	933/DL	1072,5	557	227	197	195	195	1566,5	1327	200	927	40	472	500	65	25	450	20	100	42	280	50	(2)	490	4	287
PMX(S)T	/9	11	160M	952/EM	1072,5	557	227	197	195	195	1703,5	1413	250	913	40	531	500	65	25	450	20	100	42	280	50	(2)	627	4	374
PMX(S)T	50/10	5,5	132S	934/DL	1132,5	617	227	197	195	195	1591,5	1349	200	949	40	472	500	65	25	450	20	100	42	280	50	(2)	455	4	292
PMX(S)T	/10	7,5	132M	935/DL	1132,5	617	227	197	195	195	1626,5	1387	250	887	40	472	500	65	25	450	20	100	42	280	50	(2)	490	4	301
PMX(S)T	/10	11	160M	936/EM	1132,5	617	227	197	195	195	1763,5	1473	250	973	40	531	500	65	25	450	20	100	42	280	50	(2)	627	4	387
PMX(S)T	50/11	7,5	132M	937/DL	1192,5	677	227	197	195	195	1686,5	1447	250	947	40	472	500	65	25	450	20	100	42	280	50	(2)	490	4	314
PMX(S)T	/11	11	160M	938/EM	1192,5	677	227	197	195	195	1823,5	1533	250	1033	40	531	500	65	25	450	20	100	42	280	50	(2)	627	4	400
PMX(S)T	50/12	7,5	132M	939/DL	1252,5	737	227	197	195	195	1746,5	1507	250	1007	40	472	500	65	25	450	20	100	42	280	50	(2)	490	4	327
PMX(S)T	/12	11	160M	940/EM	1252,5	737	227	197	195	195	1883,5	1593	250	1093	40	531	500	65	25	450	20	100	42	280	50	(2)	627	4	413
PMX(S)T	/12	15	160L	941/EM	1252,5	737	227	197	195	195	1883,5	1637	250	1137	40	531	500	65	25	450	20	100	42	280	50	(2)	627	4	426
PMX(S)T	50/13	7,5	132M	942/DL	1312,5	797	227	197	195	195	1806,5	1567	250	1067	40	472	500	65	25	450	20	100	42	280	50	(2)	490	4	341

BGAM = Base and coupling

* = Indicatives values according to the type of motor installed.

(2) PMXT=40 bar PMXST=63 bar

BGAM = Рама и муфта

* = Приблизит. значения в завис. от марки двигателя.

(2) PMXT=40 бар PMXST=63 бар

BGAM = Base giunto e coprigiunto

* = Valori indicativi in funzione della marca di motore utilizzato.

(2) PMXT=40 bar PMXST=63 bar

Selection - dimensions and weights for base mounted electric pumps
 Подбор - габариты и вес электронасосов на раме
 Selezione - dimensioni e pesi elettropompe su base

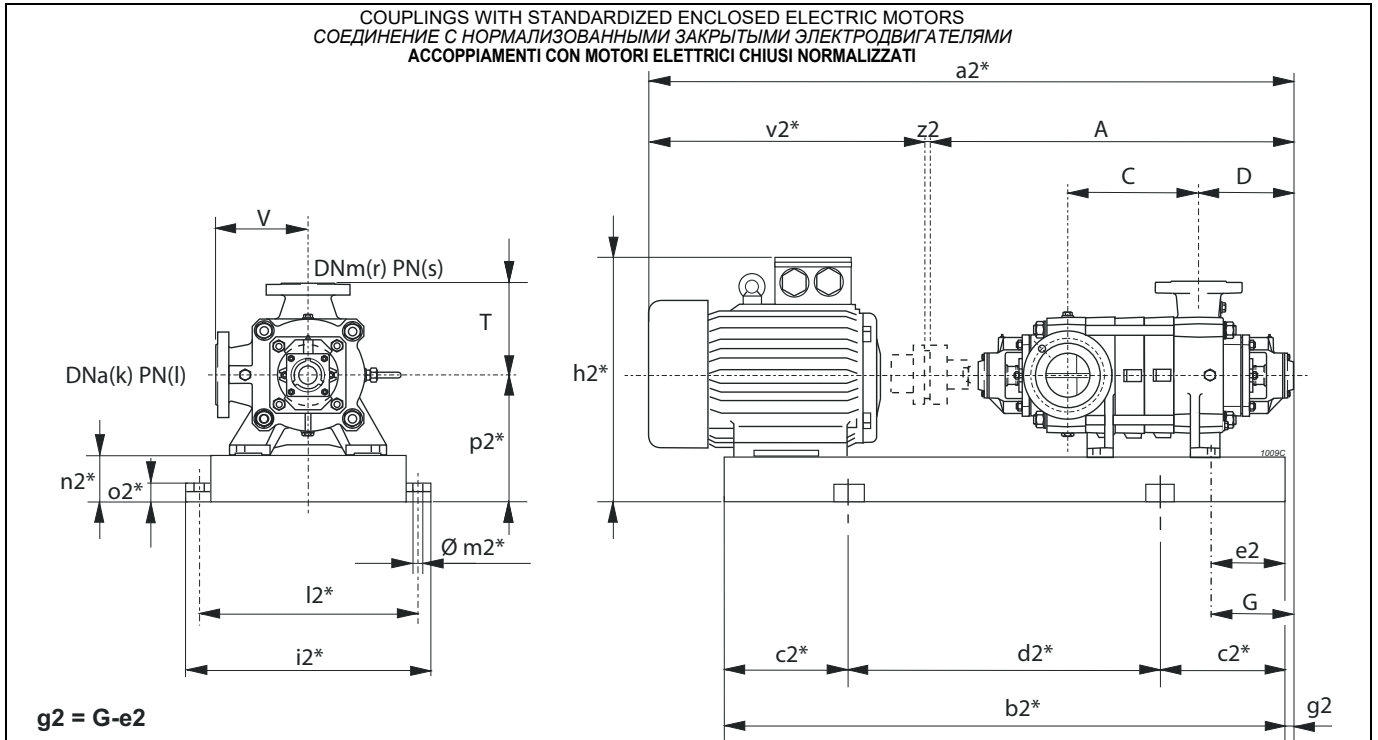

* Valori indicativi in funzione della marca di motore utilizzato
 Indicatives values according to the type of motor installed

Приблизительные значения в зависимости от марки двигателя.

Pump Насос Помпа		Motor Двигатель Motore		BGAM	A	C	D	G	T	V	a2*	b2*	c2*	d2*	e2	h2*	i2*	k	l	l2*	m2*	n2*	o2*	p2*	r	s	v2*	z2	Weight Вес Peso
Series Серия Serie	Type Тип Tipo	[kW]	Size Размер Grand.	Type Тип Tipo	[mm]																								[kg]
PMX(S)T	/13	11	160M	943/EM	1312,5	797	227	197	195	195	1943,5	1653	300	1053	40	531	500	65	25	450	20	100	42	280	50	(2)	627	4	427
PMX(S)T	/13	15	160L	944/EM	1312,5	797	227	197	195	195	1943,5	1697	300	1097	40	531	500	65	25	450	20	100	42	280	50	(2)	627	4	440
PMX(S)T	50/14	7,5	132M	945/DL	1372,5	857	227	197	195	195	1866,5	1627	250	1127	40	472	500	65	25	450	20	100	42	280	50	(2)	490	4	354
PMX(S)T	/14	11	160M	946/EM	1372,5	857	227	197	195	195	2003,5	1713	300	1113	40	531	500	65	25	450	20	100	42	280	50	(2)	627	4	440
PMX(S)T	/14	15	160L	947/EM	1372,5	857	227	197	195	195	2003,5	1757	300	1157	40	531	500	65	25	450	20	100	42	280	50	(2)	627	4	453
PMX(S)T	50/15	11	160M	949/EM	1432,5	917	227	197	195	195	2063,5	1773	300	1173	40	531	500	65	25	450	20	100	42	280	50	(2)	627	4	453
PMX(S)T	/15	15	160L	950/EM	1432,5	917	227	197	195	195	2063,5	1817	300	1217	40	531	500	65	25	450	20	100	42	280	50	(2)	627	4	466

BGAM = Base and coupling

* = Indicatives values according to the type of motor installed.

(2) PMXT=40 bar PMXST=63 bar

BGAM = Рама и муфта

* = Приблизит. значения в завис. от марки двигателя.

(2) PMXT=40 бар PMXST=63 бар

BGAM = Base giunto e coprigiunto

* = Valori indicativi in funzione della marca di motore utilizzato.

(2) PMXT=40 bar PMXST=63 bar

Utilization field Область применения Campo di utilizzo ≥ 60% η		
Stage number: compatibly with the maximum pressure. Кол-во ступеней: совместимое с макс. давлением. Numero stadi: compatibilmente con la pressione massima di esercizio.		
Type Тип Tipo	MIN.	MAX.
PMXT	2	16
PMXST	2	16
PMXHT	6	16
NB. For two-stage pumps only, reduce efficiency by one point. Только для двухступенчатых насосов - снизить КПД на 1 единицу. Solamente per le pompe a due stadi, ridurre di un punto il rendimento.		

Wet moment of inertia J Момент инерции J мокрый Momento d'inerzia J bagnato J=1/4PD ² - [kg m ²]		
Impeller type Тип раб. колеса Girante tipo	PMX(S/H)T65/1	For each additional stage Для каждой доп. ступени Per ogni stadio in più
Stainless steel Нержав. сталь Acciaio inox	0,0142	0,0117

Maximum permissible power Макс. допустимая мощность Massime potenze ammissibili		
Type Тип Tipo	N/n MAX.	
PMXT	0,08	
PMXST	0,08	
PMXHT	0,08	
For seal limits and calculation formulas of the maximum permissible powers, see technical data section. Ограничения по уплотнениям и формулы расчета макс. допустимой мощности - см. раздел "Технические данные". Per i limiti tenute e le formule di calcolo delle massime potenze ammissibili, vedere sezione dati tecnici.		

PERFORMANCES EACH INTERMEDIATE STAGE
ХАРАКТЕРИСТИКИ ОДНОЙ СТУПЕНИ
PRESTAZIONI PER STADIO

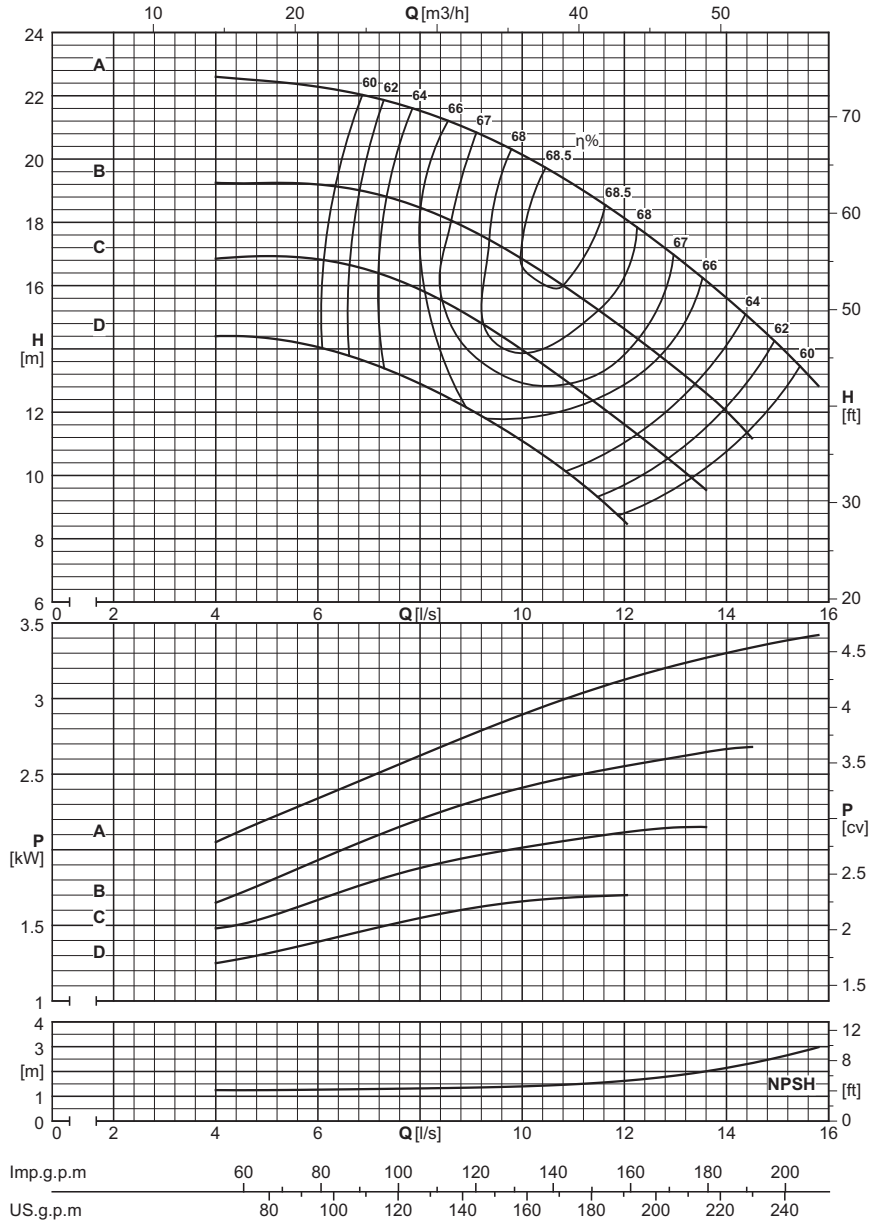

Dna x DNm	Impeller type Тип раб. кол. / Girante tipo	Capacity - Расход - Portata																					
		[l/s]	0	6	6,5	7	7,5	8	8,5	9	9,5	10	10,5	11	11,5	12	12,5	13	13,5	14	14,5	15	15,5
		[m ³ /h]	0	21,6	23,4	25,2	27	28,8	30,6	32,4	34,2	36	37,8	39,6	41,4	43,2	45	46,8	48,6	50,4	52,2	54	55,8
		[l/min]	0	360	390	420	450	480	510	540	570	600	630	660	690	720	750	780	810	840	870	900	930

		PMX(S/H)T65/1																					
80x65	D	[m]	13,5	14,5	14	13,5	13	12,5	12,5	12	11,5	11	10,5	9,9	9,2	8,5	8,2						
80x65	D	[kW]		1,4	1,4	1,5	1,5	1,6	1,6	1,6	1,7	1,7	1,7	1,7	1,7	1,7	1,8						
80x65	C	[m]	15,5	17	17	16,5	16,5	16	15,5	15,5	14,5	14,5	13,5	13	12	11,5	11	10,5	9,6	9,3			
80x65	C	[kW]		1,7	1,7	1,8	1,8	1,9	1,9	1,9	2	2	2	2,1	2,1	2,1	2,1	2,1	2,1	2,2			
80x65	B	[m]	18,5	20	20	18,5	18,5	18	19	17,5	17,5	17	16,5	16	15,5	14,5	14,5	13,5	13	12	11		
80x65	B	[kW]		1,9	2	2,1	2,2	2,2	2,3	2,3	2,4	2,4	2,4	2,5	2,5	2,6	2,6	2,6	2,7	2,7	2,7		
80x65	A	[m]	22,5		22	22,5	22,5	21	21	21	20,5	20,5	19,5	19	18,5	18	17,5	17	16,5	15,5	15	14,5	13
80x65	A	[kW]			2,4	2,5	2,5	2,7	2,7	2,8	2,8	2,9	3	3	3,1	3,1	3,1	3,3	3,3	3,3	3,3	3,3	3,4

		NPSH																					
	[m]		1,3	1,3	1,3	1,3	1,3	1,3	1,4	1,4	1,4	1,4	1,4	1,5	1,5	1,6	1,7	1,8	2	2,1	2,3	2,6	2,9

Utilization field Область применения Campo di utilizzo ≥ 60% η		
Stage number: compatibly with the maximum pressure. Кол-во ступеней: совместимое с макс. давлением. Numero stadi: compatibilmente con la pressione massima di esercizio.		
Type Тип Tipo	MIN.	MAX.
PMXT	2	16
PMXST	2	16
PMXHT	6	16
NB. For two-stage pumps only, reduce efficiency by one point. Только для двухступенчатых насосов - снизить КПД на 1 единицу. Solamente per le pompe a due stadi, ridurre di un punto il rendimento.		

Wet moment of inertia J Момент инерции J мокрый Momento d'inerzia J bagnato J=¼PD ² - [kg m ²]		
Impeller type Тип раб. колеса Girante tipo	PMX(S/H)T65/1	For each additional stage Для каждой доп. ступени Per ogni stadio in più
Stainless steel Нержав. сталь Acciaio inox	0,0142	0,0117

Maximum permissible power Макс. допустимая мощность Massime potenze ammissibili	
Type Тип Tipo	N/h MAX.
PMXT	0,08
PMXST	0,08
PMXHT	0,08
For seal limits and calculation formulas of the maximum permissible powers, see technical data section. Ограничения по уплотнениям и формулы расчета макс. допустимой мощности - см. раздел "Технические данные". Per i limiti tenute e le formule di calcolo delle massime potenze ammissibili, vedere sezione dati tecnici.	

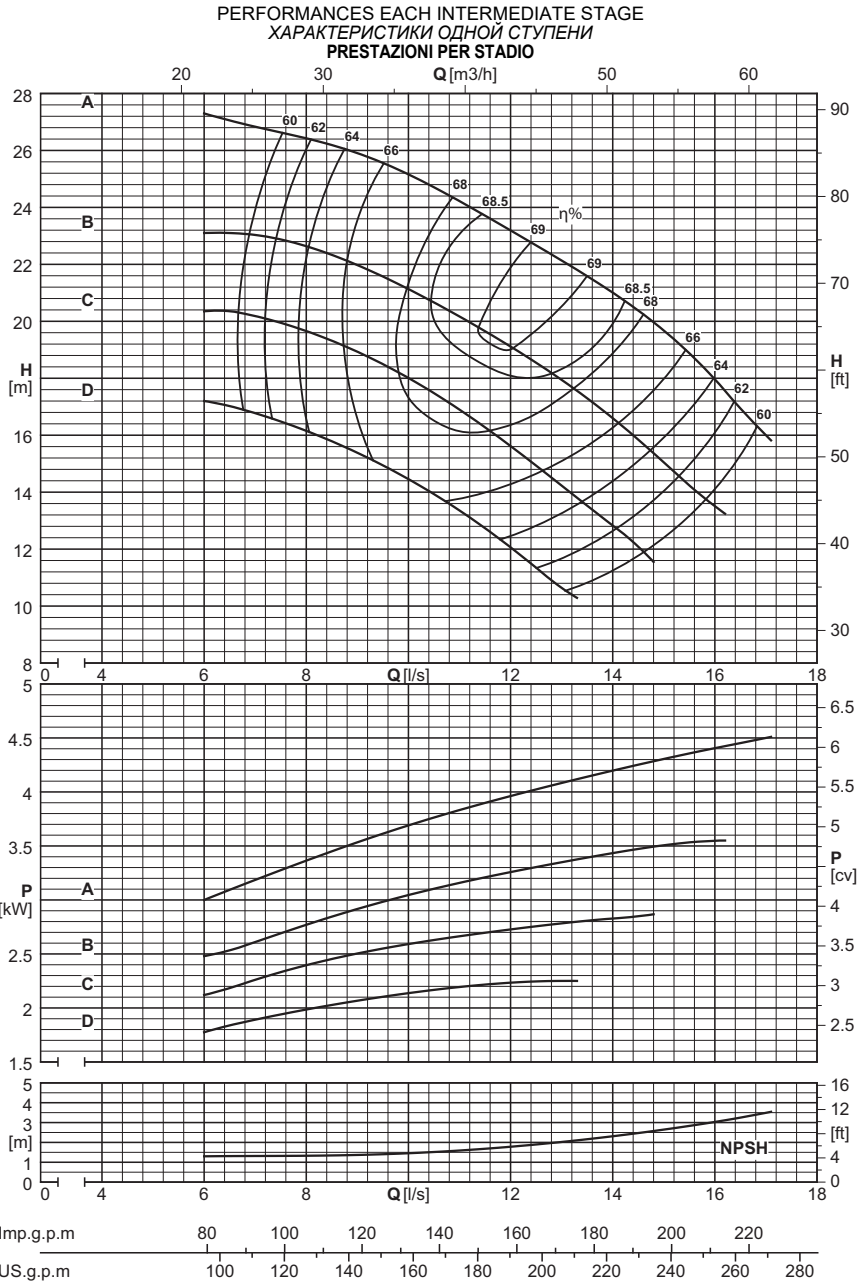

Dna x Dnm		Impeller type / Тип раб. кол. / Girante tipo	[l/s]	0	7	7,5	8	8,5	9	9,5	10	10,5	11	11,5	12	12,5	13	13,5	14	14,5	15	15,5	16	16,5	17									
			[m³/h]	0	25,2	27	28,8	30,6	32,4	34,2	36	37,8	39,6	41,4	43,2	45	46,8	48,6	50,4	52,2	54	55,8	57,6	59,4	61,2									
			[l/min]	0	420	450	480	510	540	570	600	630	660	690	720	750	780	810	840	870	900	930	960	990	1020									
Capacity - Расход - Portata																																		
PMX(S/H)T65/1																																		
80x65	D	[m]	16	17	16,5	16,5	15,5	15	14,5	14,5	13,5	13	12	11,5	10,5	10																		
80x65	D	[kW]		1,9	1,9	2	2	2,1	2,1	2,2	2,2	2,2	2,2	2,2	2,3	2,3																		
80x65	C	[m]	18,5	20	19,5	19,5	20	18,5	18,5	18	17,5	17	16,5	15,5	15	14	13,5	13	12	11,5														
80x65	C	[kW]		2,3	2,4	2,4	2,5	2,5	2,5	2,6	2,6	2,6	2,7	2,7	2,8	2,8	2,8	2,8	2,9	2,9														
80x65	B	[m]	22	23,5	23	23,5	22,5	22,5	22	21	20,5	20	19,5	19	18,5	18	17,5	16,5	16	15,5	14	13,5	13,5											
80x65	B	[kW]		2,6	2,7	2,7	2,8	2,9	2,9	3,1	3,1	3,2	3,2	3,3	3,3	3,4	3,4	3,4	3,5	3,5	3,5	3,5	3,6											
80x65	A	[m]	27,5	27,5	27,5	25,5	26	25,5	25,5	25,5	25	24,5	23,5	23,5	22,5	22	21,5	21	20,5	19,5	19	19	17	16										
80x65	A	[kW]		3,1	3,2	3,4	3,5	3,6	3,6	3,7	3,7	3,8	3,9	4	4	4,1	4,1	4,2	4,2	4,3	4,4	4,4	4,4	4,5										
NPSH																																		
[m]																																		
			1,3	1,3	1,3	1,4	1,4	1,4	1,5	1,5	1,6	1,7	1,8	1,9	2	2,2	2,3	2,5	2,7	2,8	3	3,3	3,5											

Utilization field Область применения Campo di utilizzo ≥ 60% η		
Stage number: compatibly with the maximum pressure. Кол-во ступеней: совместимое с макс. давлением. Numero stadi: compatibilmente con la pressione massima di esercizio.		
Type Тип Tipo	MIN.	MAX.
PMXT	2	14
PMXST	2	14
PMXHT	6	16
NB. For two-stage pumps only, reduce efficiency by one point. Только для двухступенчатых насосов - снизить КПД на 1 единицу. Solamente per le pompe a due stadi, ridurre di un punto il rendimento.		

Wet moment of inertia J Момент инерции J мокрый Momento d'inerzia J bagnato J=1/4PD ² - [kg m ²]		
Impeller type Тип раб. колеса Girante tipo	PMX(S/H)T65/1	For each additional stage Для каждой доп. ступени Per ogni stadio in più
Stainless steel Нержав. сталь Acciaio inox	0,0142	0,0117

Maximum permissible power Макс. допустимая мощность Massime potenze ammissibili	
Type Тип Tipo	N/n MAX.
PMXT	0,08
PMXST	0,08
PMXHT	0,08
For seal limits and calculation formulas of the maximum permissible powers, see technical data section. Ограничения по уплотнениям и формулы расчета макс. допустимой мощности - см. раздел "Технические данные". Per i limiti tenute e le formule di calcolo delle massime potenze ammissibili, vedere sezione dati tecnici.	

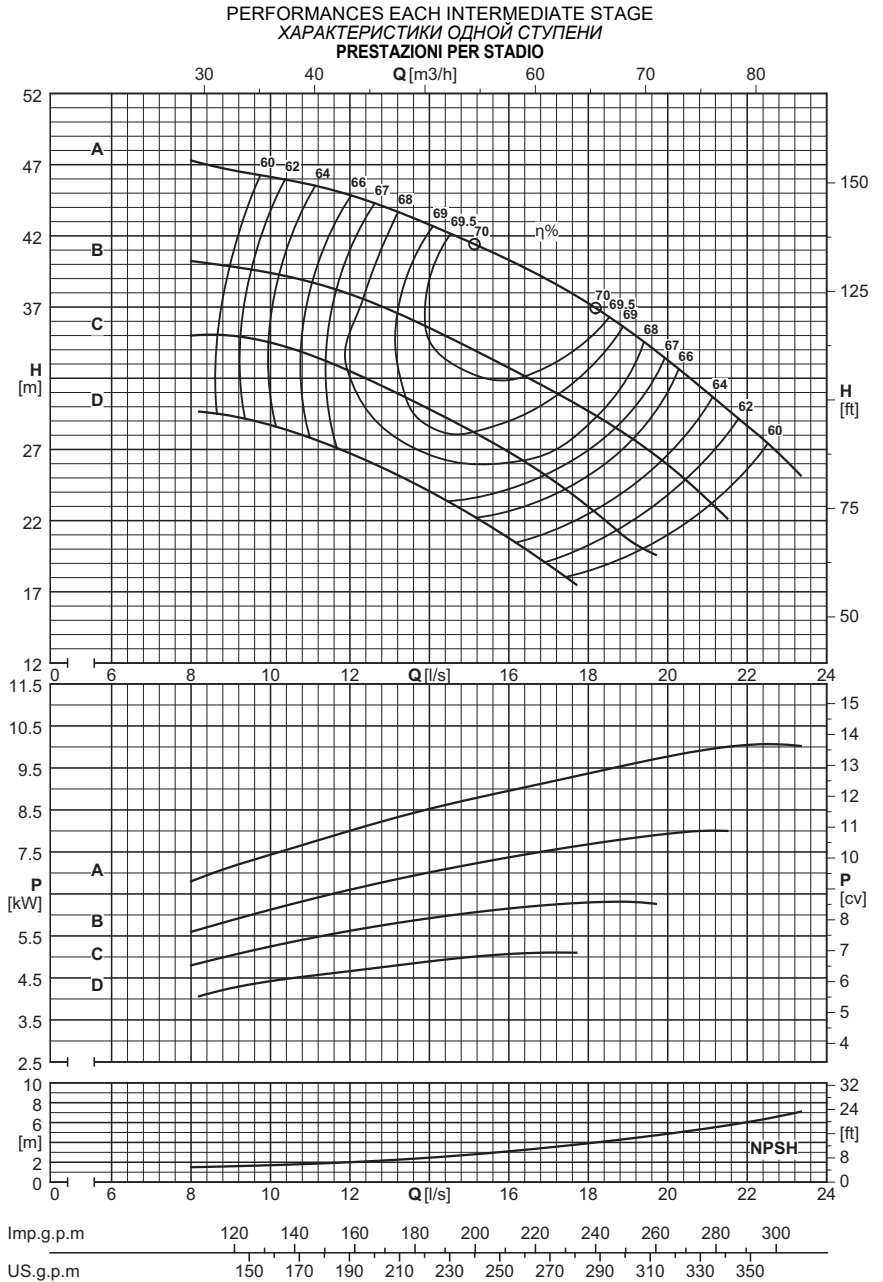

Dna x DNm	Impeller type Тип раб. кол. / Girante tipo	Capacity - Расход - Portata																						
		[l/s]	0	9	10	11	12	13	14	15	16	17	18	19	20	21	22	23						
		[m³/h]	0	32,4	36	39,6	43,2	46,8	50,4	54	57,6	61,2	64,8	68,4	72	75,6	79,2	82,8						
		[l/min]	0	540	600	660	720	780	840	900	960	1020	1080	1140	1200	1260	1320	1380						

		PMX(S/H)T65/1																							
80x65	D	[m]	28	30	29	28	27	25,5	24	22,5	20,5	18,5	17												
80x65	D	[kW]		4,2	4,4	4,5	4,6	4,7	4,8	4,9	5	5	5,2												
80x65	C	[m]	32,5	36	34	34	32	31	30	28,5	27	25	23	20,5	19,5										
80x65	C	[kW]		5	5,3	5,4	5,7	5,8	5,9	6,1	6,2	6,2	6,3	6,3	6,4										
80x65	B	[m]	38	38,5	40	38,5	38,5	37	35	34	32,5	31,5	29,5	28	26	24	21,5								
80x65	B	[kW]		6	6,1	6,4	6,5	6,8	7,1	7,2	7,4	7,5	7,7	7,9	7,9	8,1	8,2								
80x65	A	[m]	47,5		44,5	46,5	45,5	43,5	42	42	40,5	39	37	35,5	33	31	29	25,5							
80x65	A	[kW]			7,6	7,6	8	8,3	8,7	8,6	8,9	9,2	9,5	9,5	9,7	10	10,1	9,9							

		NPSH																						
	[m]		1,6	1,7	1,8	2	2,2	2,5	2,8	3,1	3,5	3,9	4,4	4,9	5,4	5,9	7							

Utilization field Область применения Campo di utilizzo ≥ 60% η		
Stage number: compatibly with the maximum pressure. Кол-во ступеней: совместимое с макс. давлением. Numero stadi: compatibilmente con la pressione massima di esercizio.		
Type Тип Tipo	MIN.	MAX.
PMXT	2	9
PMXST	2	9
PMXHT	6	12
NB. For two-stage pumps only, reduce efficiency by one point. Только для двухступенчатых насосов - снизить КПД на 1 единицу. Solamente per le pompe a due stadi, ridurre di un punto il rendimento.		

Wet moment of inertia J Момент инерции J мокрый Momento d'inerzia J bagnato J=¼PD ² - [kg m ²]		
Impeller type Тип раб. колеса Girante tipo	PMX(S/H)T65/1	For each additional stage Для каждой доп. ступени Per ogni stadio in più
Stainless steel Нержав. сталь Acciaio inox	0,0142	0,0117

Maximum permissible power Макс. допустимая мощность Massime potenze ammissibili	
Type Тип Tipo	N/h MAX.
PMXT	0,08
PMXST	0,08
PMXHT	0,08
For seal limits and calculation formulas of the maximum permissible powers, see technical data section. Ограничения по уплотнениям и формулы расчета макс. допустимой мощности - см. раздел "Технические данные". Per i limiti tenute e le formule di calcolo delle massime potenze ammissibili, vedere sezione dati tecnici.	

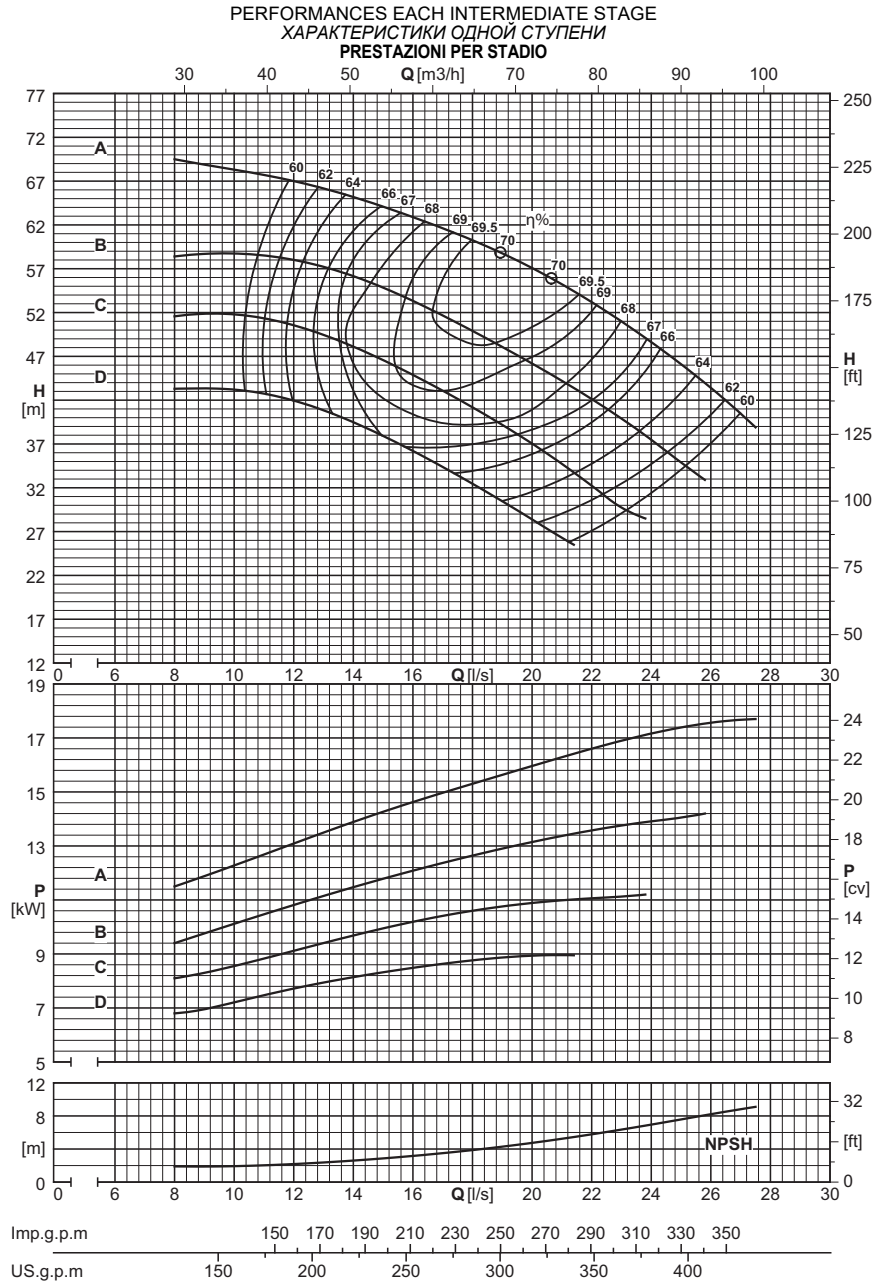

Dna x Dnm	Impeller type Тип раб. кол. / Girante tipo	Capacity - Расход - Portata																										
		[l/s]	0	10	11	12	13	14	15	16	17	18	19	20	21	22	23	24	25	26	27							
		[m³/h]	0	36	39,6	43,2	46,8	50,4	54	57,6	61,2	64,8	68,4	72	75,6	79,2	82,8	86,4	90	93,6	97,2							
		[l/min]	0	600	660	720	780	840	900	960	1020	1080	1140	1200	1260	1320	1380	1440	1500	1560	1620							

		PMX(S/H)T65/1																																			
80x65	D	[m]	40,5	43,5	42	42,5	40,5	40	39	36	34,5	32,5	30,5	28,5	26,5	25																					
80x65	D	[kW]		7,2	7,5	7,6	8	8	8,3	8,6	8,6	8,8	8,8	8,9	9,1	9,2																					
80x65	C	[m]	47	50	52	51	49,5	47,5	46,5	45	43	41	39	37	34,5	32	30	28,5																			
80x65	C	[kW]		8,8	8,7	9	9,4	9,8	10,1	10,1	10,3	10,6	10,8	11	10,9	11	11,1	11,3																			
80x65	B	[m]	55		57	56	56	55	53	54	52	50	48	46	44	42	40	37,5	35,5	32,5																	
80x65	B	[kW]			10,6	11	11,3	11,7	12	11,9	12,2	12,5	12,8	13,1	13,3	13,6	13,8	13,9	14,1	14,3																	
80x65	A	[m]	69		68	67	66	65	64	63	62	60	59	57	55	53	50	48,5	45,5	43	39,5																
80x65	A	[kW]			12,6	13	13,4	13,8	14,2	14,5	14,8	15	15,5	16	16,5	16,5	17,5	17,5	17,5	17,5																	

		NPSH																																	
	[m]		1,9	2	2,2	2,4	2,6	2,9	3,2	3,5	3,9	4,2	4,7	5,3	5,8	6,3	6,9	7,5	8,1	8,9															

Overall dimensions and weights
 Общие габариты и вес
 Dimensioni di ingombro e pesi

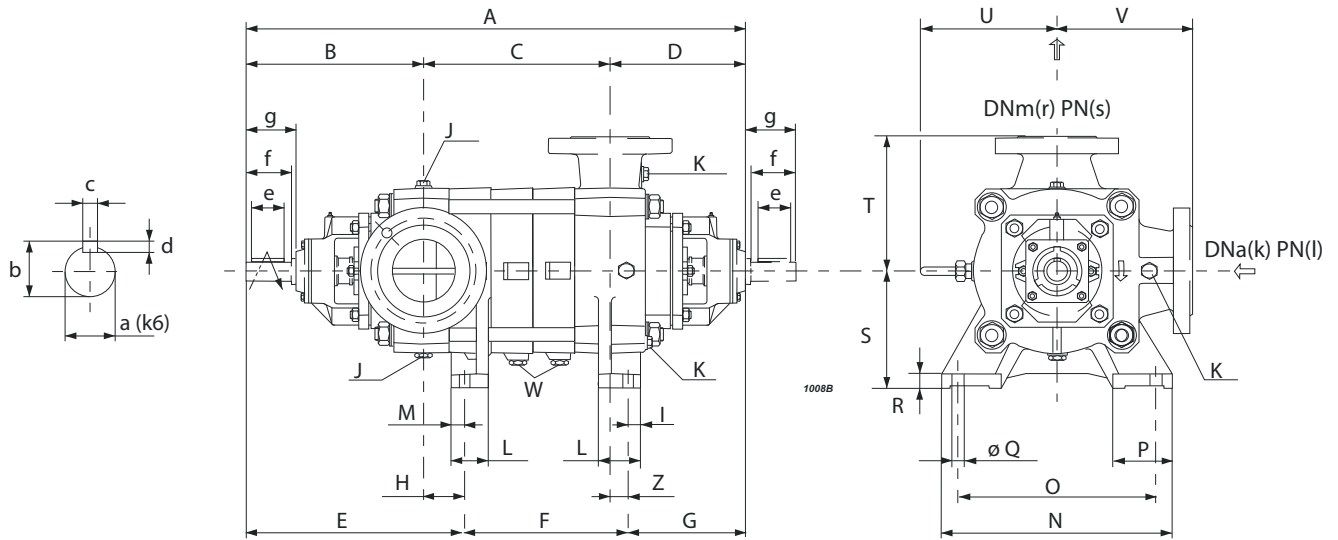

Series Серия Serie	Type Тип Tipo	A	B	C	D	E	F	G	H	S	T	U	V	Z	Weight Вес Peso
		[mm]													
PMX(S)T	65/2	688	289	170	229	354	135	199	65	180	220	239	220	30	127
PMX(S)T	65/3	753	289	235	229	354	200	199	65	180	220	239	220	30	142
PMX(S)T	65/4	818	289	300	229	354	265	199	65	180	220	239	220	30	157
PMX(S)T	65/5	883	289	365	229	354	330	199	65	180	220	239	220	30	173
PMX(S/H)T	65/6	948	289	430	229	354	395	199	65	180	220	239	220	30	188
PMX(S/H)T	65/7	1013	289	495	229	354	460	199	65	180	220	239	220	30	203
PMX(S/H)T	65/8	1078	289	560	229	354	525	199	65	180	220	239	220	30	218
PMX(S/H)T	65/9	1143	289	625	229	354	590	199	65	180	220	239	220	30	234
PMX(S/H)T	65/10	1208	289	690	229	354	655	199	65	180	220	239	220	30	249
PMX(S/H)T	65/11	1273	289	755	229	354	720	199	65	180	220	239	220	30	264
PMX(S/H)T	65/12	1338	289	820	229	354	785	199	65	180	220	239	220	30	279
PMX(S/H)T	65/13	1403	289	885	229	354	850	199	65	180	220	239	220	30	295
PMX(S/H)T	65/14	1468	289	950	229	354	915	199	65	180	220	239	220	30	310
PMX(S/H)T	65/15	1533	289	1015	229	354	980	199	65	180	220	239	220	30	325
PMX(S/H)T	65/16	1598	289	1080	229	354	1045	199	65	180	220	239	220	30	340

Foot dimensions Размеры ножек Dimensioni dei piedi							
I	L	M	N	O	P	Q	R
[mm]							
20	65	21	370	320	90	18	23

Shaft projection Выступ вала Sporgenza d'albero						
a	b	c	d	e	f	g
[mm]						
32	35	10	8	60	75	90

Flanges Фланцы Flange				
Type Тип Tipo	(k) DNa	(l) PN	(r) DNm	(s) PN
	[mm]	[bar]	[mm]	[bar]
PMXT	80	25	65	40
PMXST	80	25	65	63
PMXHT	80	40	65	100

Plugs Пробки Tappi		
J	K	W
G 1/2	G 3/8	G 1/4

Selection - dimensions and weights for base mounted electric pumps
 Подбор - габариты и вес электронасосов на раме
 Selezione - dimensioni e pesi elettropompe su base

COUPLINGS WITH STANDARDIZED ENCLOSED ELECTRIC MOTORS
 СОЕДИНЕНИЕ С НОРМАЛИЗОВАННЫМИ ЗАКРЫТЫМИ ЭЛЕКТРОДВИГАТЕЛЯМИ
 ACCOPPIAMENTI CON MOTORI ELETTRICI CHIUSI NORMALIZZATI

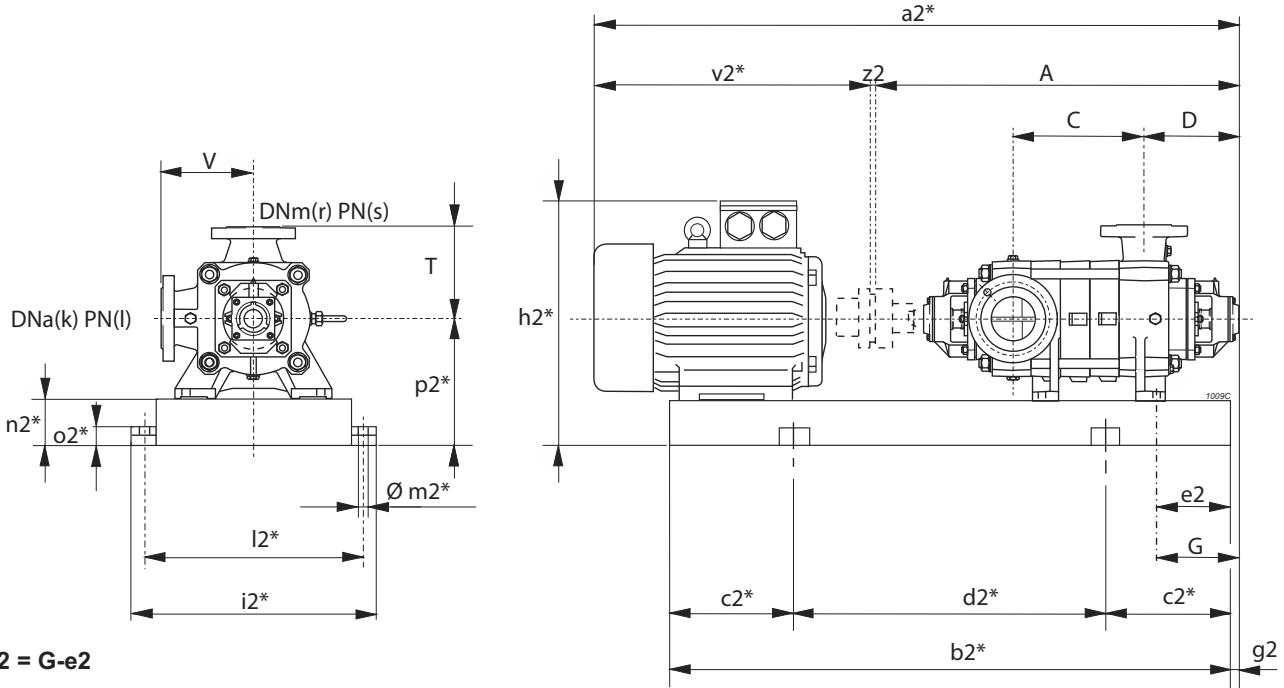

$g2 = G - e2$

* Valori indicativi in funzione della marca di motore utilizzato - Indicatives values according to the type of motor installed - Приблизительные значения в зависимости от марки двигателя

Pump Насос Помпа	Motor Двигатель Motore	BGAM	A	C	D	G	T	V	a2*	b2*	c2*	d2*	e2	h2*	i2*	k	l	l2*	m2*	n2*	o2*	p2*	r	s	v2*	z2	Weight Вес Peso		
Series Серия Serie	Type Тип Tipo	[kW]	Size Размер Grand.	Type Тип Tipo	[mm]																				[kg]				
PMX(S)T	65/2	11	160M	411/DM	687,5	170	229	199	220	220	1318,5	1026	150	726	40	531	500	80	(1)	450	20	100	42	280	65	(2)	627	4	284
PMX(S)T	/2	15	160M	411/DM	687,5	170	229	199	220	220	1318,5	1026	150	726	40	531	500	80	(1)	450	20	100	42	280	65	(2)	627	4	295
PMX(S)T	/2	18,5	160L	412/DM	687,5	170	229	199	220	220	1318,5	1070	200	670	40	531	500	80	(1)	450	20	100	42	280	65	(2)	627	4	308
PMX(S)T	/2	22	180M	413/EM	687,5	170	229	199	220	220	1356,5	1080	200	680	40	550	500	80	(1)	450	20	100	42	280	65	(2)	665	4	348
PMX(S)T	65/3	15	160M	414/DM	752,5	235	229	199	220	220	1383,5	1091	200	691	40	531	500	80	(1)	450	20	100	42	280	65	(2)	627	4	311
PMX(S)T	/3	18,5	160L	415/DM	752,5	235	229	199	220	220	1383,5	1135	200	735	40	531	500	80	(1)	450	20	100	42	280	65	(2)	627	4	323
PMX(S)T	/3	22	180M	416/EM	752,5	235	229	199	220	220	1421,5	1145	200	745	40	550	500	80	(1)	450	20	100	42	280	65	(2)	665	4	363
PMX(S)T	/3	30	200L	417/FM	752,5	235	229	199	220	220	1494,5	1238	200	838	60	600	540	80	(1)	490	20	100	42	300	65	(2)	738	4	425
PMX(S)T	/3	37	200L	417/FM	752,5	235	229	199	220	220	1494,5	1238	200	838	60	600	540	80	(1)	490	20	100	42	300	65	(2)	738	4	453
PMX(S)T	65/4	18,5	160L	418/DM	817,5	300	229	199	220	220	1448,5	1200	200	800	40	531	500	80	(1)	450	20	100	42	280	65	(2)	627	4	339
PMX(S)T	/4	22	180M	419/EM	817,5	300	229	199	220	220	1486,5	1210	200	810	40	550	500	80	(1)	450	20	100	42	280	65	(2)	665	4	379
PMX(S)T	/4	30	200L	420/FM	817,5	300	229	199	220	220	1559,5	1303	200	903	60	600	540	80	(1)	490	20	100	42	300	65	(2)	738	4	440
PMX(S)T	/4	37	200L	420/FM	817,5	300	229	199	220	220	1559,5	1303	200	903	60	600	540	80	(1)	490	20	100	42	300	65	(2)	738	4	468
PMX(S)T	/4	45	225M	421/FM	817,5	300	229	199	220	220	1596,5	1339	200	939	70	675	585	80	(1)	535	20	120	42	345	65	(2)	775	4	544
PMX(S)T	65/5	22	180M	422/EM	882,5	365	229	199	220	220	1551,5	1275	200	875	40	550	500	80	(1)	450	20	100	42	280	65	(2)	665	4	394
PMX(S)T	/5	30	200L	423/FM	882,5	365	229	199	220	220	1624,5	1368	250	868	60	600	540	80	(1)	490	20	100	42	300	65	(2)	738	4	456
PMX(S)T	/5	37	200L	423/FM	882,5	365	229	199	220	220	1624,5	1368	250	868	60	600	540	80	(1)	490	20	100	42	300	65	(2)	738	4	484
PMX(S)T	/5	45	225M	424/FM	882,5	365	229	199	220	220	1661,5	1404	250	904	70	675	585	80	(1)	535	20	120	42	345	65	(2)	775	4	560
PMX(S)T	/5	55	250M	425/GM	882,5	365	229	199	220	220	1756,5	1486	250	986	80	745	635	80	(1)	585	20	120	42	370	65	(2)	870	4	670
PMX(S/H)T	65/6	30	200L	426/FM	947,5	430	229	199	220	220	1689,5	1433	250	933	60	600	540	80	(1)	490	20	100	42	300	65	(2)	738	4	471
PMX(S/H)T	/6	37	200L	426/FM	947,5	430	229	199	220	220	1689,5	1433	250	933	60	600	540	80	(1)	490	20	100	42	300	65	(2)	738	4	499
PMX(S/H)T	/6	45	225M	427/FM	947,5	430	229	199	220	220	1726,5	1469	250	969	70	675	585	80	(1)	535	20	120	42	345	65	(2)	775	4	576
PMX(S/H)T	/6	55	250M	428/GM	947,5	430	229	199	220	220	1821,5	1551	250	1051	80	745	635	80	(1)	585	20	120	42	370	65	(2)	870	4	686
PMX(S/H)T	/6	75	280S	429/HM	947,5	430	229	199	220	220	1951,5	1608	250	1108	90	815	695	80	(1)	645	20	140	42	420	65	(2)	1000	4	916
PMX(S/H)T	65/7	30	200L	430/FM	1012,5	495	229	199	220	220	1754,5	1498	250	998	60	600	540	80	(1)	490	20	100	42	300	65	(2)	738	4	487
PMX(S/H)T	/7	37	200L	430/FM	1012,5	495	229	199	220	220	1754,5	1498	250	998	60	600	540	80	(1)	490	20	100	42	300	65	(2)	738	4	515
PMX(S/H)T	/7	45	225M	431/FM	1012,5	495	229	199	220	220	1791,5	1534	250	1034	70	675	585	80	(1)	535	20	120	42	345	65	(2)	775	4	591
PMX(S/H)T	/7	55	250M	432/GM	1012,5	495	229	199	220	220	1886,5	1616	250	1116	80	745	635	80	(1)	585	20	120	42	370	65	(2)	870	4	701

BGAM = Base and coupling

* = Indicatives values according to the type of motor installed.

○ Motor in IE4 efficiency class according to EU REGULATION 2019/1781. Available in other efficiency classes for non-EU markets.

BGAMA = Рама и муфта

* = Приблизит. значения в зависимости от марки двигателя.

○ Двигатель класса эффективности IE4 в соответствии с РЕГЛАМЕНТОМ ЕС 2019/1781. Имеются варианты в других классах эффективности для рынков за пределами ЕС.

BGAM = Base giunto e coprigiunto

* = Valori indicativi in funzione della marca di motore utilizzato.

○ Motore in classe di efficienza IE4 in conformità al REGOLAMENTO UE2019/1781. Disponibili in altre classi di efficienza per mercati extra UE.

- (1) PMXT=25 bar PMXST=25 bar PMXHT=40 bar
- (2) PMXT=40 bar PMXST=63 bar PMXHT=100 bar

- (1) PMXT=25 бар PMXST=25 бар PMXHT=40 бар
- (2) PMXT=40 бар PMXST=63 бар PMXHT=100 бар

- (1) PMXT=25 bar PMXST=25 bar PMXHT=40 bar
- (2) PMXT=40 bar PMXST=63 bar PMXHT=100 bar

COUPLINGS WITH STANDARDIZED ENCLOSED ELECTRIC MOTORS
 СОЕДИНЕНИЕ С НОРМАЛИЗОВАННЫМИ ЗАКРЫТЫМИ ЭЛЕКТРОДВИГАТЕЛЯМИ
 ACCOPPIAMENTI CON MOTORI ELETTRICI CHIUSI NORMALIZZATI

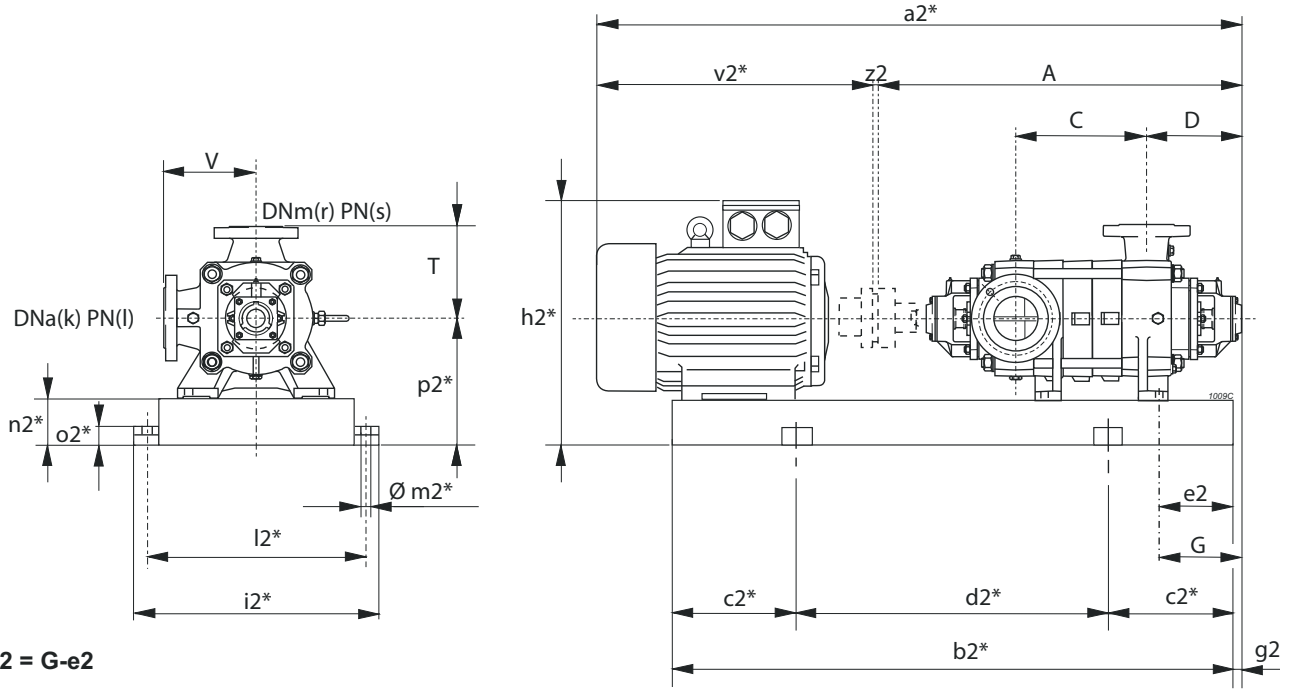

* Valori indicati in funzione della marca di motore utilizzato - Indicatives values according to the type of motor installed - Приблизительные значения в зависимости от марки двигателя

Pump Насос Помпа		Motor Двигатель Motore		BGAM	A	C	D	G	T	V	a2*	b2*	c2*	d2*	e2	h2*	i2*	k	l	l2*	m2*	n2*	o2*	p2*	r	s	v2*	z2	Weight Вес Peso
Series Серия Serie	Type Тип Tipo	[kW]	Size Размер Grand.	Type Тип Tipo	[mm]																								[kg]
PMX(S/H)T	/7	75	280S	433/HM	1012,5	495	229	199	220	220	2016,5	1673	300	1073	90	815	695	80	(1)	645	20	140	42	420	65	(2)	1000	4	932
PMX(S/H)T	/7	90	280M	434/HM	1012,5	495	229	199	220	220	2067,5	1724	300	1124	90	815	695	80	(1)	645	20	140	42	420	65	(2)	1051	4	1061
PMX(S/H)T	65/8	37	200L	435/FM	1077,5	560	229	199	220	220	1819,5	1563	250	1063	60	600	540	80	(1)	490	20	100	42	300	65	(2)	738	4	530
PMX(S/H)T	/8	45	225M	436/FM	1077,5	560	229	199	220	220	1856,5	1599	250	1099	70	675	585	80	(1)	535	20	120	42	345	65	(2)	775	4	607
PMX(S/H)T	/8	55	250M	437/GM	1077,5	560	229	199	220	220	1951,5	1681	300	1081	80	745	635	80	(1)	585	20	120	42	370	65	(2)	870	4	717
PMX(S/H)T	/8	75	280S	438/HM	1077,5	560	229	199	220	220	2081,5	1738	300	1138	90	815	695	80	(1)	645	20	140	42	420	65	(2)	1000	4	948
PMX(S/H)T	/8	90	280M	439/HM	1077,5	560	229	199	220	220	2132,5	1789	300	1189	90	815	695	80	(1)	645	20	140	42	420	65	(2)	1051	4	1077
PMX(S/H)T	65/9	45	225M	440/FM	1142,5	625	229	199	220	220	1921,5	1664	300	1064	70	675	585	80	(1)	535	20	120	42	345	65	(2)	775	4	623
PMX(S/H)T	/9	55	250M	441/GM	1142,5	625	229	199	220	220	2016,5	1746	300	1146	80	745	635	80	(1)	585	20	120	42	370	65	(2)	870	4	733
PMX(S/H)T	/9	75	280S	442/HM	1142,5	625	229	199	220	220	2146,5	1803	300	1203	90	815	695	80	(1)	645	20	140	42	420	65	(2)	1000	4	964
PMX(S/H)T	/9	90	280M	443/HM	1142,5	625	229	199	220	220	2197,5	1854	300	1254	90	815	695	80	(1)	645	20	140	42	420	65	(2)	1051	4	1093
PMX(S/H)T	/9	110	315S	444/IM	1142,5	625	229	199	220	220	2327,5	1910	300	1310	100	1030	780	80	(1)	730	22	160	50	475	65	(2)	1181	4	1369
PMX(S/H)T	65/10	45	225M	445/FM	1207,5	690	229	199	220	220	1986,5	1729	300	1129	70	675	585	80	(1)	535	20	120	42	345	65	(2)	775	4	639
PMX(S/H)T	/10	55	250M	446/GM	1207,5	690	229	199	220	220	2081,5	1811	300	1211	80	745	635	80	(1)	585	20	120	42	370	65	(2)	870	4	748
PMX(S/H)T	/10	75	280S	447/HM	1207,5	690	229	199	220	220	2211,5	1868	300	1268	90	815	695	80	(1)	645	20	140	42	420	65	(2)	1000	4	980
PMX(S/H)T	/10	90	280M	448/HM	1207,5	690	229	199	220	220	2262,5	1919	300	1319	90	815	695	80	(1)	645	20	140	42	420	65	(2)	1051	4	1109
PMX(S/H)T	/10	110	315S	449/IM	1207,5	690	229	199	220	220	2392,5	1975	350	1275	100	1030	780	80	(1)	730	22	160	50	475	65	(2)	1181	4	1385
PMX(S/H)T	65/11	55	250M	450/GM	1272,5	755	229	199	220	220	2146,5	1876	300	1276	80	745	635	80	(1)	585	20	120	42	370	65	(2)	870	4	764
PMX(S/H)T	/11	75	280S	451/HM	1272,5	755	229	199	220	220	2276,5	1933	300	1333	90	815	695	80	(1)	645	20	140	42	420	65	(2)	1000	4	996
PMX(S/H)T	/11	90	280M	452/HM	1272,5	755	229	199	220	220	2327,5	1984	350	1284	90	815	695	80	(1)	645	20	140	42	420	65	(2)	1051	4	1125
PMX(S/H)T	/11	110	315S	453/IM	1272,5	755	229	199	220	220	2457,5	2040	350	1340	100	1030	780	80	(1)	730	22	160	50	475	65	(2)	1181	4	1331
PMX(S/H)T	/11	132	315M	454/IM	1272,5	755	229	199	220	220	2567,5	2099	350	1399	100	1030	780	80	(1)	730	22	160	50	475	65	(2)	1291	4	1403
PMX(S/H)T	65/12	55	250M	455/GM	1337,5	820	229	199	220	220	2211,5	1941	300	1341	80	745	635	80	(1)	585	20	120	42	370	65	(2)	870	4	780
PMX(S/H)T	/12	75	280S	456/HM	1337,5	820	229	199	220	220	2341,5	1998	350	1298	90	815	695	80	(1)	645	20	140	42	420	65	(2)	1000	4	1012
PMX(S/H)T	/12	90	280M	457/HM	1337,5	820	229	199	220	220	2392,5	2049	350	1349	90	815	695	80	(1)	645	20	140	42	420	65	(2)	1051	4	1141
PMX(S/H)T	/12	110	315S	458/IM	1337,5	820	229	199	220	220	2522,5	2105	350	1405	100	1030	780	80	(1)	730	22	160	50	475	65	(2)	1181	4	1345
PMX(S/H)T	/12	132	315M	459/IM	1337,5	820	229	199	220	220	2632,5	2164	350	1464	100	1030	780	80	(1)	730	22	160	50	475	65	(2)	1291	4	1417

BGAM = Base and coupling

* = Indicatives values according to the type of motor installed.

○ Motor in IE4 efficiency class according to EU REGULATION 2019/1781. Available in other efficiency classes for non-EU markets.

- (1) PMXT=25 bar PMXST=25 bar PMXHT=40 bar
- (2) PMXT=40 bar PMXST=63 bar PMXHT=100 bar

BGAMA = Рама и муфта

* = Приблизит. значения в зависимости от марки двигателя.

○ Двигатель класса эффективности IE4 в соответствии с РЕГЛАМЕНТОМ ЕС 2019/1781. Имеются варианты в других классах эффективности для рынков за пределами ЕС.

- (1) PMXT=25 бар PMXST=25 бар PMXHT=40 бар
- (2) PMXT=40 бар PMXST=63 бар PMXHT=100 бар

BGAM = Base giunto e coprigiunto

* = Valori indicativi in funzione della marca di motore utilizzato.

○ Motore in classe di efficienza IE4 in conformità al REGOLAMENTO UE2019/1781. Disponibili in altre classi di efficienza per mercati extra UE.

- (1) PMXT=25 bar PMXST=25 bar PMXHT=40 bar
- (2) PMXT=40 bar PMXST=63 bar PMXHT=100 bar

COUPLINGS WITH STANDARDIZED ENCLOSED ELECTRIC MOTORS
 СОЕДИНЕНИЕ С НОРМАЛИЗОВАННЫМИ ЗАКРЫТЫМИ ЭЛЕКТРОДВИГАТЕЛЯМИ
 ACCORPIAMENTI CON MOTORI ELETTRICI CHIUSI NORMALIZZATI

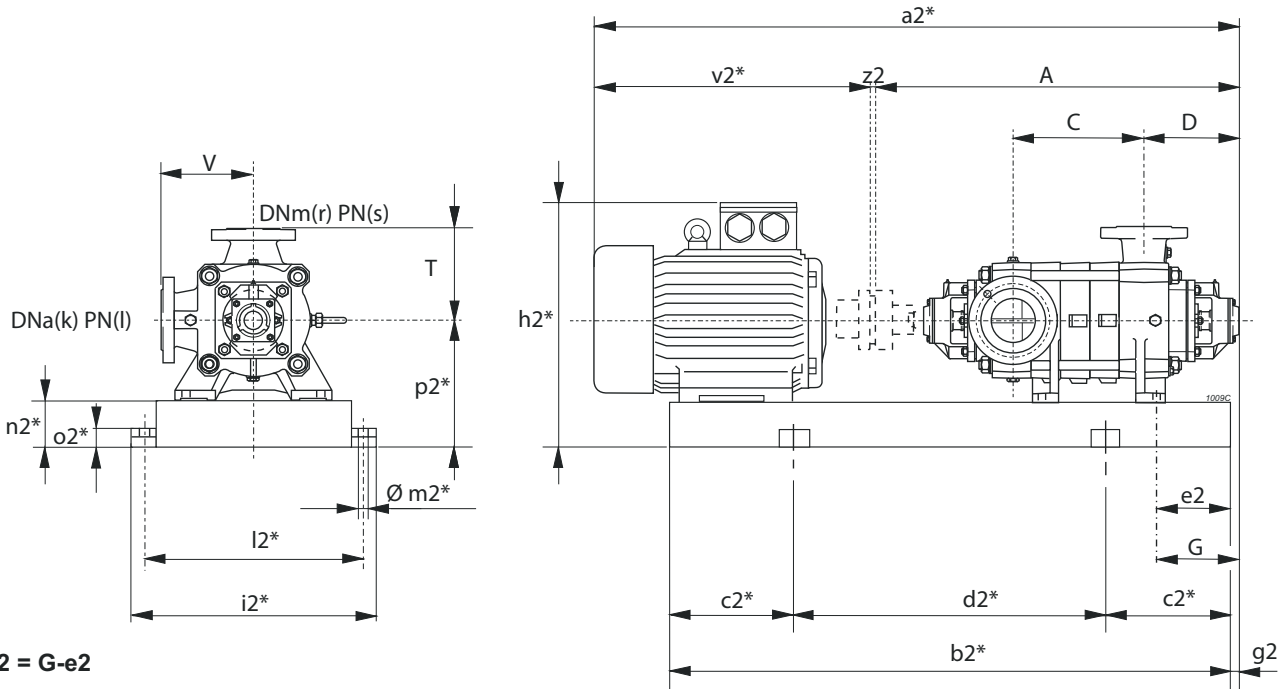

$g2 = G - e2$

* Valori indicativi in funzione della marca di motore utilizzato - Indicatives values according to the type of motor installed - Приблизительные значения в зависимости от марки двигателя

Pump Насос Pompa		Motor Двигатель Motore			BGAM	A	C	D	G	T	V	a2*	b2*	c2*	d2*	e2	h2*	i2*	k	l	l2*	m2*	n2*	o2*	p2*	r	s	v2*	z2	Weight Вес Peso
Series Серия Serie	Type Тип Tipo	[kW]	Size Размер Grand.	Type Тип Tipo	[mm]																									[kg]
PMX(S/H)T	65/13	75	280S	460/HM	1402,5	885	229	199	220	220	2406,5	2063	350	1363	90	815	695	80	(1)	645	20	140	42	420	65	(2)	1000	4	1028	
PMX(S/H)T	/13	90	280M	461/HM	1402,5	885	229	199	220	220	2457,5	2114	350	1414	90	815	695	80	(1)	645	20	140	42	420	65	(2)	1051	4	1157	
PMX(S/H)T	/13	110	315S	462/IM	1402,5	885	229	199	220	220	2587,5	2170	350	1470	100	1030	780	80	(1)	730	22	160	50	475	65	(2)	1181	4	1434	
PMX(S/H)T	/13	132	315M	463/IM	1402,5	885	229	199	220	220	2697,5	2280	400	1480	100	1030	780	80	(1)	730	22	160	50	475	65	(2)	1291	4	1511	
PMX(S/H)T	/13	160	315L	463/IM	1402,5	885	229	199	220	220	2697,5	2280	400	1480	100	1030	780	80	(1)	730	22	160	50	475	65	(2)	1291	4	1589	
PMX(S/H)T	65/14	75	280S	464/HM	1467,5	950	229	199	220	220	2471,5	2128	350	1428	90	815	695	80	(1)	645	20	140	42	420	65	(2)	1000	4	1045	
PMX(S/H)T	/14	90	280M	465/HM	1467,5	950	229	199	220	220	2522,5	2179	350	1479	90	815	695	80	(1)	645	20	140	42	420	65	(2)	1051	4	1173	
PMX(S/H)T	/14	110	315S	466/IM	1467,5	950	229	199	220	220	2652,5	2235	350	1535	100	1030	780	80	(1)	730	22	160	50	475	65	(2)	1181	4	1451	
PMX(S/H)T	/14	132	315M	467/IM	1467,5	950	229	199	220	220	2762,5	2345	400	1545	100	1030	780	80	(1)	730	22	160	50	475	65	(2)	1291	4	1527	
PMX(S/H)T	/14	160	315L	467/IM	1467,5	950	229	199	220	220	2762,5	2345	400	1545	100	1030	780	80	(1)	730	22	160	50	475	65	(2)	1291	4	1605	
PMX(S/H)T	65/15	90	280M	500/HM	1532,5	1015	229	199	220	220	2587,5	2244	350	1544	90	815	695	80	(1)	645	20	140	42	420	65	(2)	1051	4	1189	
PMX(S/H)T	/15	110	315S	501/IM	1532,5	1015	229	199	220	220	2717,5	2300	400	1500	100	1030	780	80	(1)	730	22	160	50	475	65	(2)	1181	4	1467	
PMX(S/H)T	/15	132	315M	502/IM	1532,5	1015	229	199	220	220	2827,5	2359	400	1559	100	1030	780	80	(1)	730	22	160	50	475	65	(2)	1291	4	1541	
PMX(S/H)T	/15	160	315L	503/IM	1532,5	1015	229	199	220	220	2827,5	2410	400	1610	100	1030	780	80	(1)	730	22	160	50	475	65	(2)	1291	4	1621	
PMX(S/H)T	/15	200	315L	504/IE4/LQ	1532,5	1015	229	199	220	220	2917,5	2500	400	1700	198	1030	780	80	(1)	730	22	160	50	475	65	(2)	1381	4	1754	
PMX(S/H)T	65/16	90	280M	511/HM	1597,5	1080	229	199	220	220	2652,5	2309	400	1509	90	815	695	80	(1)	645	20	140	42	420	65	(2)	1051	4	1205	
PMX(S/H)T	/16	110	315S	512/IM	1597,5	1080	229	199	220	220	2782,5	2365	400	1565	100	1030	780	80	(1)	730	22	160	50	475	65	(2)	1181	4	1483	
PMX(S/H)T	/16	132	315M	513/IM	1597,5	1080	229	199	220	220	2892,5	2424	400	1624	100	1030	780	80	(1)	730	22	160	50	475	65	(2)	1291	4	1558	
PMX(S/H)T	/16	160	315L	514/IM	1597,5	1080	229	199	220	220	2892,5	2475	400	1675	100	1030	780	80	(1)	730	22	160	50	475	65	(2)	1291	4	1638	
PMX(S/H)T	/16	200	315L	515/IE4/LQ	1597,5	1080	229	199	220	220	2982,5	2565	450	1665	198	1030	780	80	(1)	730	22	160	50	475	65	(2)	1381	4	1770	

BGAM = Base and coupling

* = Indicatives values according to the type of motor installed.

○ Motor in IE4 efficiency class according to EU REGULATION 2019/1781. Available in other efficiency classes for non-EU markets.

BGAMA = Рама и муфта

* = Приблизит. значения в зависимости от марки двигателя.

○ Двигатель класса эффективности IE4 в соответствии с РЕГЛАМЕНТОМ ЕС 2019/1781. Имеются варианты в других классах эффективности для рынков за пределами ЕС.

BGAM = Base giunto e coprigiunto

* = Valori indicativi in funzione della marca di motore utilizzato.

○ Motore in classe di efficienza IE4 in conformità al REGOLAMENTO UE2019/1781. Disponibili in altre classi di efficienza per mercati extra UE.

(1) PMXT=25 bar PMXST=25 bar PMXHT=40 bar

(2) PMXT=40 bar PMXST=63 bar PMXHT=100 bar

(1) PMXT=25 бар PMXST=25 бар PMXHT=40 бар

(2) PMXT=40 бар PMXST=63 бар PMXHT=100 бар

(1) PMXT=25 bar PMXST=25 bar PMXHT=40 bar

(2) PMXT=40 bar PMXST=63 bar PMXHT=100 bar

Selection - dimensions and weights for base mounted electric pumps
 Подбор - габариты и вес электронасосов на раме
 Selezione - dimensioni e pesi elettropompe su base

COUPLINGS WITH STANDARDIZED ENCLOSED ELECTRIC MOTORS
 СОЕДИНЕНИЕ С НОРМАЛИЗОВАННЫМИ ЗАКРЫТЫМИ ЭЛЕКТРОДВИГАТЕЛЯМИ
 ACCOPPIAMENTI CON MOTORI ELETTRICI CHIUSI NORMALIZZATI

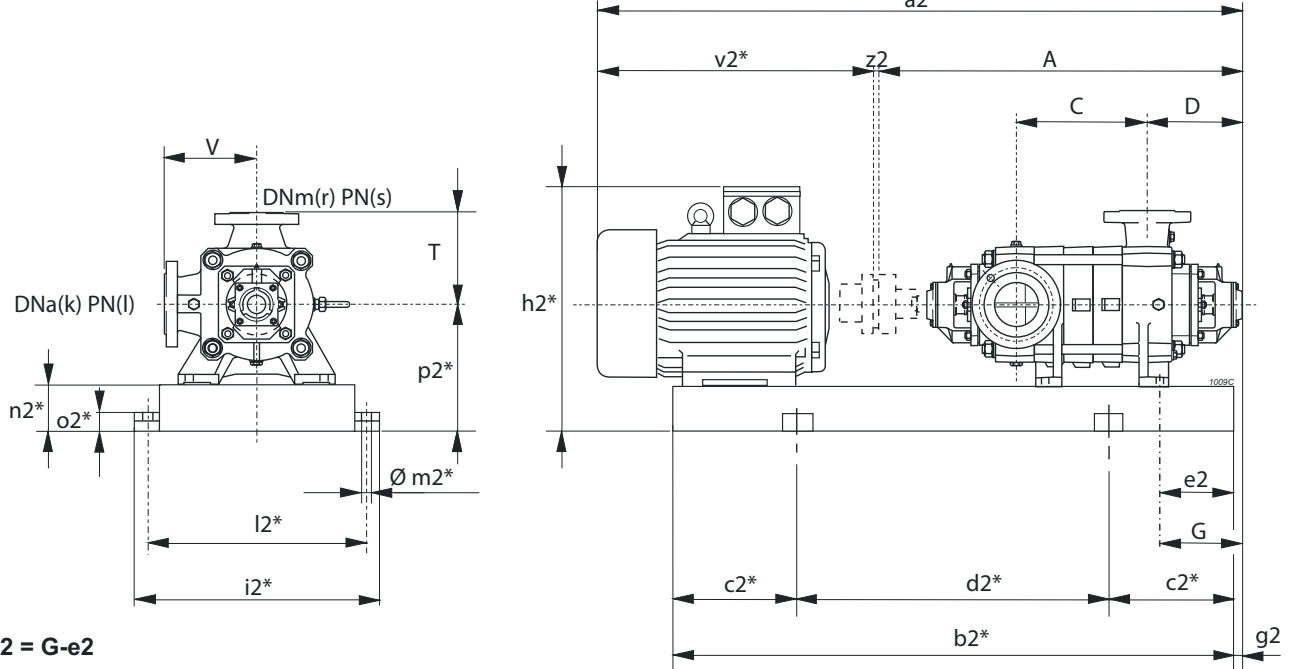

$g2 = G - e2$

* Valori indicativi in funzione della marca di motore utilizzato - Indicatives values according to the type of motor installed - Приблизительные значения в зависимости от марки двигателя

Pump Насос Ромпа		Motor Двигатель Motore		BGAM	A	C	D	G	T	V	a2*	b2*	c2*	d2*	e2	h2*	i2*	k	l	l2*	m2*	n2*	o2*	p2*	r	s	v2*	z2	Weight Вес Peso
Series Серия Serie	Type Тип Tipo	[kW]	Size Размер Grand.	Type Тип Tipo	[mm]																								[kg]
PMX(S)T	65/2	1,1	90S	197/CL	687,5	170	229	199	220	220	1046,5	774	150	474	40	418	500	80	(1)	450	20	100	42	280	65	(2)	355	4	170
PMX(S)T	/2	1,5	90L	198/CL	687,5	170	229	199	220	220	1076,5	799	150	499	40	418	500	80	(1)	450	20	100	42	280	65	(2)	385	4	175
PMX(S)T	/2	2,2	100L	199/CL	687,5	170	229	199	220	220	1096,5	834	150	534	40	430	500	80	(1)	450	20	100	42	280	65	(2)	405	4	188
PMX(S)T	/2	3	100L	199/CL	687,5	170	229	199	220	220	1096,5	834	150	534	40	430	500	80	(1)	450	20	100	42	280	65	(2)	405	4	192
PMX(S)T	65/3	2,2	100L	201/CL	752,5	235	229	199	220	220	1161,5	899	150	599	40	430	500	80	(1)	450	20	100	42	280	65	(2)	405	4	203
PMX(S)T	/3	3	100L	201/CL	752,5	235	229	199	220	220	1161,5	899	150	599	40	430	500	80	(1)	450	20	100	42	280	65	(2)	405	4	207
PMX(S)T	/3	4	112M	202/CL	752,5	235	229	199	220	220	1196,5	906	150	606	40	452	500	80	(1)	450	20	100	42	280	65	(2)	440	4	209
PMX(S)T	/3	5,5	132S	203/DL	752,5	235	229	199	220	220	1211,5	967	150	667	40	472	500	80	(1)	450	20	100	42	280	65	(2)	455	4	219
PMX(S)T	65/4	2,2	100L	204/CL	817,5	300	229	199	220	220	1226,5	964	150	664	40	430	500	80	(1)	450	20	100	42	280	65	(2)	405	4	219
PMX(S)T	/4	3	100L	204/CL	817,5	300	229	199	220	220	1226,5	964	150	664	40	430	500	80	(1)	450	20	100	42	280	65	(2)	405	4	223
PMX(S)T	/4	4	112M	205/CL	817,5	300	229	199	220	220	1261,5	971	150	671	40	452	500	80	(1)	450	20	100	42	280	65	(2)	440	4	224
PMX(S)T	/4	5,5	132S	206/DL	817,5	300	229	199	220	220	1276,5	1032	150	732	40	472	500	80	(1)	450	20	100	42	280	65	(2)	455	4	234
PMX(S)T	/4	7,5	132M	207/DL	817,5	300	229	199	220	220	1311,5	1070	200	670	40	472	500	80	(1)	450	20	100	42	280	65	(2)	490	4	243
PMX(S)T	65/5	3	100L	222/CL	882,5	365	229	199	220	220	1291,5	1029	150	729	40	430	500	80	(1)	450	20	100	42	280	65	(2)	405	4	238
PMX(S)T	/5	4	112M	223/CL	882,5	365	229	199	220	220	1326,5	1036	150	736	40	452	500	80	(1)	450	20	100	42	280	65	(2)	440	4	240
PMX(S)T	/5	5,5	132S	224/DL	882,5	365	229	199	220	220	1341,5	1097	200	697	40	472	500	80	(1)	450	20	100	42	280	65	(2)	455	4	249
PMX(S)T	/5	7,5	132M	225/DL	882,5	365	229	199	220	220	1376,5	1135	200	735	40	472	500	80	(1)	450	20	100	42	280	65	(2)	490	4	258
PMX(S/H)T	65/6	4	112M	226/CL	947,5	430	229	199	220	220	1391,5	1101	200	701	40	452	500	80	(1)	450	20	100	42	280	65	(2)	440	4	255
PMX(S/H)T	/6	5,5	132S	227/DL	947,5	430	229	199	220	220	1406,5	1162	200	762	40	472	500	80	(1)	450	20	100	42	280	65	(2)	455	4	265
PMX(S/H)T	/6	7,5	132M	228/DL	947,5	430	229	199	220	220	1441,5	1200	200	800	40	472	500	80	(1)	450	20	100	42	280	65	(2)	490	4	273
PMX(S/H)T	/6	11	160M	953/EM	947,5	430	229	199	220	220	1578,5	1286	200	886	40	531	500	80	(1)	450	20	100	42	280	65	(2)	627	4	360
PMX(S/H)T	65/7	4	112M	229/CL	1012,5	495	229	199	220	220	1456,5	1166	200	766	40	452	500	80	(1)	450	20	100	42	280	65	(2)	440	4	270
PMX(S/H)T	/7	5,5	132S	230/DL	1012,5	495	229	199	220	220	1471,5	1227	200	827	40	472	500	80	(1)	450	20	100	42	280	65	(2)	455	4	280
PMX(S/H)T	/7	7,5	132M	231/DL	1012,5	495	229	199	220	220	1506,5	1265	200	865	40	472	500	80	(1)	450	20	100	42	280	65	(2)	490	4	289
PMX(S/H)T	/7	11	160M	232/EM	1012,5	495	229	199	220	220	1643,5	1351	250	851	40	531	500	80	(1)	450	20	100	42	280	65	(2)	627	4	375
PMX(S/H)T	65/8	5,5	132S	233/DL	1077,5	560	229	199	220	220	1536,5	1292	200	892	40	472	500	80	(1)	450	20	100	42	280	65	(2)	455	4	295
PMX(S/H)T	/8	7,5	132M	234/DL	1077,5	560	229	199	220	220	1571,5	1330	200	930	40	472	500	80	(1)	450	20	100	42	280	65	(2)	490	4	304
PMX(S/H)T	/8	11	160M	235/EM	1077,5	560	229	199	220	220	1708,5	1416	250	916	40	531	500	80	(1)	450	20	100	42	280	65	(2)	627	4	390
PMX(S/H)T	/8	15	160L	236/EM	1077,5	560	229	199	220	220	1708,5	1460	250	960	40	531	500	80	(1)	450	20	100	42	280	65	(2)	627	4	403
PMX(S/H)T	65/9	5,5	132S	237/DL	1142,5	625	229	199	220	220	1601,5	1357	250	857	40	472	500	80	(1)	450	20	100	42	280	65	(2)	455	4	311
PMX(S/H)T	/9	7,5	132M	238/DL	1142,5	625	229	199	220	220	1636,5	1395	250	895	40	472	500	80	(1)	450	20	100	42	280	65	(2)	490	4	320

BGAM = Base and coupling

* = Indicatives values according to the type of motor installed.

(1) PMXT=25 bar PMXST=25 bar PMXHT=40 bar

(2) PMXT=40 bar PMXST=63 bar PMXHT=100 bar

BGAMA = Рама и муфта

* = Приблизит. значения в зависимости от марки двигателя.

(1) PMXT=25 бар PMXST=25 бар PMXHT=40 бар

(2) PMXT=40 бар PMXST=63 бар PMXHT=100 бар

BGAM = Base giunto e coprigiunto

* = Valori indicativi in funzione della marca di motore utilizzato.

(1) PMXT=25 bar PMXST=25 bar PMXHT=40 bar

(2) PMXT=40 bar PMXST=63 bar PMXHT=100 bar

COUPLINGS WITH STANDARDIZED ENCLOSED ELECTRIC MOTORS
 СОЕДИНЕНИЕ С НОРМАЛИЗОВАННЫМИ ЗАКРЫТЫМИ ЭЛЕКТРОДВИГАТЕЛЯМИ
 ACCORPIAMENTI CON MOTORI ELETTRICI CHIUSI NORMALIZZATI

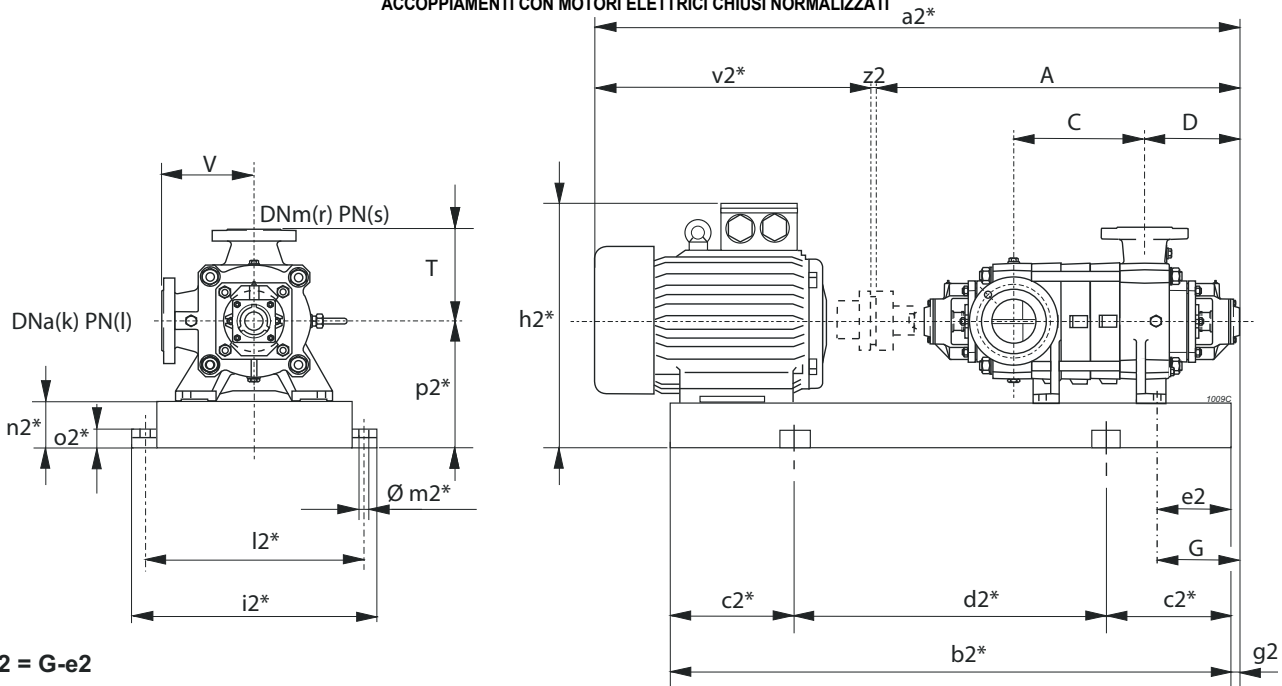

$g2 = G - e2$

* Valori indicativi in funzione della marca di motore utilizzato - Indicatives values according to the type of motor installed - Приблизительные значения в зависимости от марки двигателя

Pump Насос Помпа		Motor Двигатель Motore		BGAM	A	C	D	G	T	V	a2*	b2*	c2*	d2*	e2	h2*	i2*	k	l	l2*	m2*	n2*	o2*	p2*	r	s	v2*	z2	Weight Вес Peso	
Series Серия Serie	Type Тип Tipo	[kW]	Size Размер Grand.	Type Тип Tipo	[mm]																									[kg]
PMX(S/H)T	/9	11	160M	239/EM	1142,5	625	229	199	220	220	1773,5	1481	250	981	40	531	500	80	(1)	450	20	100	42	280	65	(2)	627	4	406	
PMX(S/H)T	/9	15	160L	240/EM	1142,5	625	229	199	220	220	1773,5	1525	250	1025	40	531	500	80	(1)	450	20	100	42	280	65	(2)	627	4	419	
PMX(S/H)T	65/10	5,5	132S	241/DL	1207,5	690	229	199	220	220	1666,5	1422	250	922	40	472	500	80	(1)	450	20	100	42	280	65	(2)	455	4	326	
PMX(S/H)T	/10	7,5	132M	242/DL	1207,5	690	229	199	220	220	1701,5	1460	250	960	40	472	500	80	(1)	450	20	100	42	280	65	(2)	490	4	335	
PMX(S/H)T	/10	11	160M	243/EM	1207,5	690	229	199	220	220	1838,5	1546	250	1046	40	531	500	80	(1)	450	20	100	42	280	65	(2)	627	4	421	
PMX(S/H)T	/10	15	160L	244/EM	1207,5	690	229	199	220	220	1838,5	1590	250	1090	40	531	500	80	(1)	450	20	100	42	280	65	(2)	627	4	434	
PMX(S/H)T	65/11	7,5	132M	284/DL	1272,5	755	229	199	220	220	1766,5	1525	250	1025	40	472	500	80	(1)	450	20	100	42	280	65	(2)	490	4	350	
PMX(S/H)T	/11	11	160M	285/EM	1272,5	755	229	199	220	220	1903,5	1611	250	1111	40	531	500	80	(1)	450	20	100	42	280	65	(2)	627	4	437	
PMX(S/H)T	/11	15	160L	286/EM	1272,5	755	229	199	220	220	1903,5	1655	300	1055	40	531	500	80	(1)	450	20	100	42	280	65	(2)	627	4	449	
PMX(S/H)T	/11	18,5	180M	287/FM	1272,5	755	229	199	220	220	1941,5	1665	300	1065	40	550	500	80	(1)	450	20	100	42	280	65	(2)	665	4	521	
PMX(S/H)T	65/12	7,5	132M	288/DL	1337,5	820	229	199	220	220	1831,5	1590	250	1090	40	472	500	80	(1)	450	20	100	42	280	65	(2)	490	4	366	
PMX(S/H)T	/12	11	160M	289/EM	1337,5	820	229	199	220	220	1968,5	1676	300	1076	40	531	500	80	(1)	450	20	100	42	280	65	(2)	627	4	452	
PMX(S/H)T	/12	15	160L	290/EM	1337,5	820	229	199	220	220	1968,5	1720	300	1120	40	531	500	80	(1)	450	20	100	42	280	65	(2)	627	4	465	
PMX(S/H)T	/12	18,5	180M	291/FM	1337,5	820	229	199	220	220	2006,5	1730	300	1130	40	550	500	80	(1)	450	20	100	42	280	65	(2)	665	4	535	
PMX(S/H)T	65/13	7,5	132M	292/DL	1402,5	885	229	199	220	220	1896,5	1655	300	1055	40	472	500	80	(1)	450	20	100	42	280	65	(2)	490	4	381	
PMX(S/H)T	/13	11	160M	293/EM	1402,5	885	229	199	220	220	2033,5	1741	300	1141	40	531	500	80	(1)	450	20	100	42	280	65	(2)	627	4	467	
PMX(S/H)T	/13	15	160L	294/EM	1402,5	885	229	199	220	220	2033,5	1785	300	1185	40	531	500	80	(1)	450	20	100	42	280	65	(2)	627	4	480	
PMX(S/H)T	/13	18,5	180M	295/FM	1402,5	885	229	199	220	220	2071,5	1795	300	1195	40	550	500	80	(1)	450	20	100	42	280	65	(2)	665	4	516	
PMX(S/H)T	65/14	11	160M	297/EM	1467,5	950	229	199	220	220	2098,5	1806	300	1206	40	531	500	80	(1)	450	20	100	42	280	65	(2)	627	4	483	
PMX(S/H)T	/14	15	160L	298/EM	1467,5	950	229	199	220	220	2098,5	1850	300	1250	40	531	500	80	(1)	450	20	100	42	280	65	(2)	627	4	496	
PMX(S/H)T	/14	18,5	180M	299/FM	1467,5	950	229	199	220	220	2136,5	1860	300	1260	40	550	500	80	(1)	450	20	100	42	280	65	(2)	665	4	531	
PMX(S/H)T	/14	22	180L	300/FM	1467,5	950	229	199	220	220	2176,5	1898	300	1298	40	550	500	80	(1)	450	20	100	42	280	65	(2)	705	4	552	
PMX(S/H)T	65/15	11	160M	505/EM	1532,5	1015	229	199	220	220	2163,5	1871	300	1271	40	531	500	80	(1)	450	20	100	42	280	65	(2)	627	4	498	
PMX(S/H)T	/15	15	160L	506/EM	1532,5	1015	229	199	220	220	2163,5	1915	300	1315	40	531	500	80	(1)	450	20	100	42	280	65	(2)	627	4	511	
PMX(S/H)T	/15	18,5	180M	507/FM	1532,5	1015	229	199	220	220	2201,5	1925	300	1325	40	550	500	80	(1)	450	20	100	42	280	65	(2)	665	4	547	
PMX(S/H)T	/15	22	180L	508/FM	1532,5	1015	229	199	220	220	2241,5	1963	350	1263	40	550	500	80	(1)	450	20	100	42	280	65	(2)	705	4	568	
PMX(S/H)T	65/16	15	160L	516/EM	1597,5	1080	229	199	220	220	2228,5	1980	350	1280	40	531	500	80	(1)	450	20	100	42	280	65	(2)	627	4	526	
PMX(S/H)T	/16	18,5	180M	517/EM	1597,5	1080	229	199	220	220	2266,5	1990	350	1290	40	550	500	80	(1)	450	20	100	42	280	65	(2)	665	4	561	
PMX(S/H)T	/16	22	180L	518/FM	1597,5	1080	229	199	220	220	2306,5	2028	350	1328	40	550	500	80	(1)	450	20	100	42	280	65	(2)	705	4	583	

BGAM = Base and coupling

* = Indicatives values according to the type of motor installed.

(1) PMXT=25 bar PMXST=25 bar PMXHT=40 bar

(2) PMXT=40 bar PMXST=63 bar PMXHT=100 bar

BGAMA = Рама и муфта

* = Приблизит. значения в зависимости от марки двигателя.

(1) PMXT=25 бар PMXST=25 бар PMXHT=40 бар

(2) PMXT=40 бар PMXST=63 бар PMXHT=100 бар

BGAM = Base giunto e coprigiunto

* = Valori indicativi in funzione della marca di motore utilizzato.

(1) PMXT=25 bar PMXST=25 bar PMXHT=40 bar

(2) PMXT=40 bar PMXST=63 bar PMXHT=100 bar

Utilization field Область применения Campo di utilizzo ≥ 60% η		
Stage number: compatibly with the maximum pressure. Кол-во ступеней: совместимое с макс. давлением. Numero stadi: compatibilmente con la pressione massima di esercizio.		
Type Тип Tipo	MIN.	MAX.
PMXT	2	16
PMXST	2	16
PMXHT	5	16
NB. For two-stage pumps only, reduce efficiency by one point. Только для двухступенчатых насосов - снизить КПД на 1 единицу. Solamente per le pompe a due stadi, ridurre di un punto il rendimento.		

Wet moment of inertia J Момент инерции J мокрый Momento d'inerzia J bagnato J=1/2PD ² - [kg m ²]		
Impeller type Тип раб. колеса Girante tipo	PMX(S/H)T80/1	For each additional stage Для каждой доп. ступени Per ogni stadio in più
Stainless steel Нержав. сталь Acciaio inox	0,0226	0,0186

Maximum permissible power Макс. допустимая мощность Massime potenze ammissibili	
Type Тип Tipo	N/n MAX.
PMXT	0,1
PMXST	0,1
PMXHT	0,1
For seal limits and calculation formulas of the maximum permissible powers, see technical data section. Ограничения по уплотнениям и формулы расчета макс. допустимой мощности - см. раздел "Технические данные". Per i limiti tenute e le formule di calcolo delle massime potenze ammissibili, vedere sezione dati tecnici.	

PERFORMANCES EACH INTERMEDIATE STAGE
ХАРАКТЕРИСТИКИ ОДНОЙ СТУПЕНИ
PRESTAZIONI PER STADIO

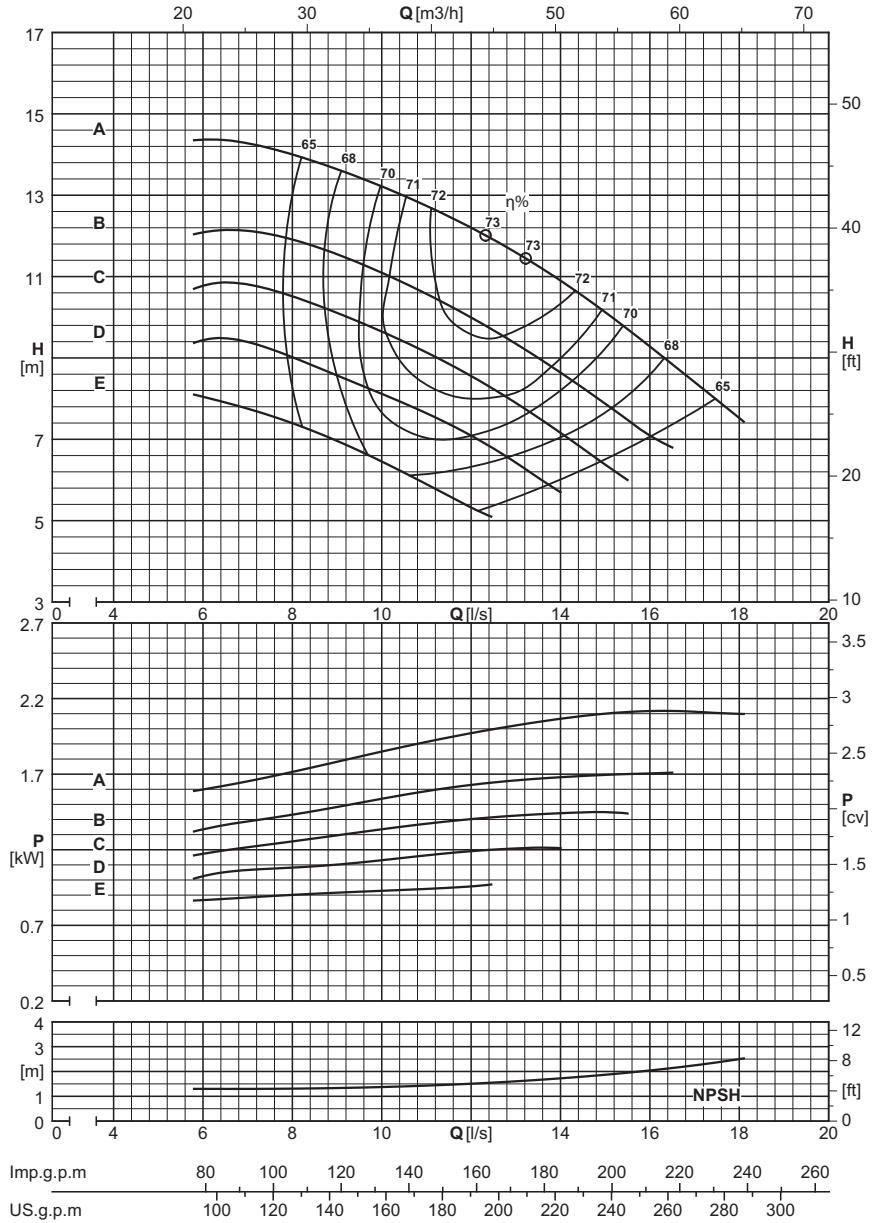

		Capacity - Расход - Portata																							
Dna x DNm	Impeller type Тип раб. кол. Girante tipo	[l/s]	0	8	8,5	9	9,5	10	10,5	11	11,5	12	12,5	13	13,5	14	14,5	15	15,5	16	16,5	17	17,5		
		[m³/h]	0	28,8	30,6	32,4	34,2	36	37,8	39,6	41,4	43,2	45	46,8	48,6	50,4	52,2	54	55,8	57,6	59,4	61,2	63		
		[l/min]	0	480	510	540	570	600	630	660	690	720	750	780	810	840	870	900	930	960	990	1020	1050		
		PMX(S/H)T80/1																							
100x80	E	[m]	8,4	7,3	7,2	6,9	6,7	6,5	6,2	5,9	5,6	5,3	5,1												
100x80	E	[kW]		0,9	0,9	0,9	0,9	0,9	0,9	0,9	1	1	1												
100x80	D	[m]	9,7	9	8,7	8,5	8,4	8,2	7,9	7,6	7,4	7,1	6,7	6,4	6	5,7									
100x80	D	[kW]		1,1	1,1	1,1	1,1	1,1	1,1	1,2	1,2	1,2	1,2	1,2	1,2	1,2									
100x80	C	[m]	11,5	10,5	10	10	9,8	9,6	9,4	9,1	8,8	8,5	8,2	7,9	7,5	7,2	6,8	6,4	6						
100x80	C	[kW]		1,3	1,3	1,3	1,3	1,3	1,4	1,4	1,4	1,4	1,4	1,4	1,4	1,4	1,5	1,4							
100x80	B	[m]	13	12	12	11,5	11,5	11	10,5	10,5	10,5	10	9,7	9,4	9	8,6	8,3	7,9	7,5	7,1	6,8				
100x80	B	[kW]		1,4	1,4	1,5	1,5	1,6	1,6	1,6	1,6	1,6	1,6	1,6	1,7	1,7	1,7	1,7	1,7	1,7	1,7				
100x80	A	[m]	15,5	13,5	13,5	13,5	13,5	13	13	12,5	12,5	12,5	12	11,5	11,5	11	10,5	10	9,7	9,2	8,7	8,5	8		
100x80	A	[kW]		1,8	1,8	1,8	1,8	1,9	1,9	1,9	1,9	1,9	2	2	2	2	2,1	2,1	2,1	2,1	2,1	2,1	2,1		
		NPSH																							
		[m]		1,3	1,3	1,3	1,4	1,4	1,4	1,4	1,5	1,5	1,6	1,6	1,7	1,7	1,8	1,9	2	2	2,1	2,2	2,4		

Utilization field Область применения Campo di utilizzo ≥ 60% η		
Stage number: compatibly with the maximum pressure. Кол-во ступеней: совместимое с макс. давлением. Numero stadi: compatibilmente con la pressione massima di esercizio.		
Type Тип Tipo	MIN.	MAX.
PMXT	2	16
PMXST	2	16
PMXHT	5	16
NB. For two-stage pumps only, reduce efficiency by one point. Только для двухступенчатых насосов - снизить КПД на 1 единицу. Solamente per le pompe a due stadi, ridurre di un punto il rendimento.		

Wet moment of inertia J Момент инерции J мокрый Momento d'inerzia J bagnato J=1/4PD ² - [kg m ²]		
Impeller type Тип раб. колеса Girante tipo	PMX(S/H)T80/1	For each additional stage Для каждой доп. ступени Per ogni stadio in più
Stainless steel Нержав. сталь Acciaio inox	0,0226	0,0186

Maximum permissible power Макс. допустимая мощность Massime potenze ammissibili	
Type Тип Tipo	N/n MAX.
PMXT	0,1
PMXST	0,1
PMXHT	0,1
For seal limits and calculation formulas of the maximum permissible powers, see technical data section. Ограничения по уплотнениям и формулы расчета макс. допустимой мощности - см. раздел "Технические данные". Per i limiti tenute e le formule di calcolo delle massime potenze ammissibili, vedere sezione dati tecnici.	

PERFORMANCES EACH INTERMEDIATE STAGE
ХАРАКТЕРИСТИКИ ОДНОЙ СТУПЕНИ
PRESTAZIONI PER STADIO

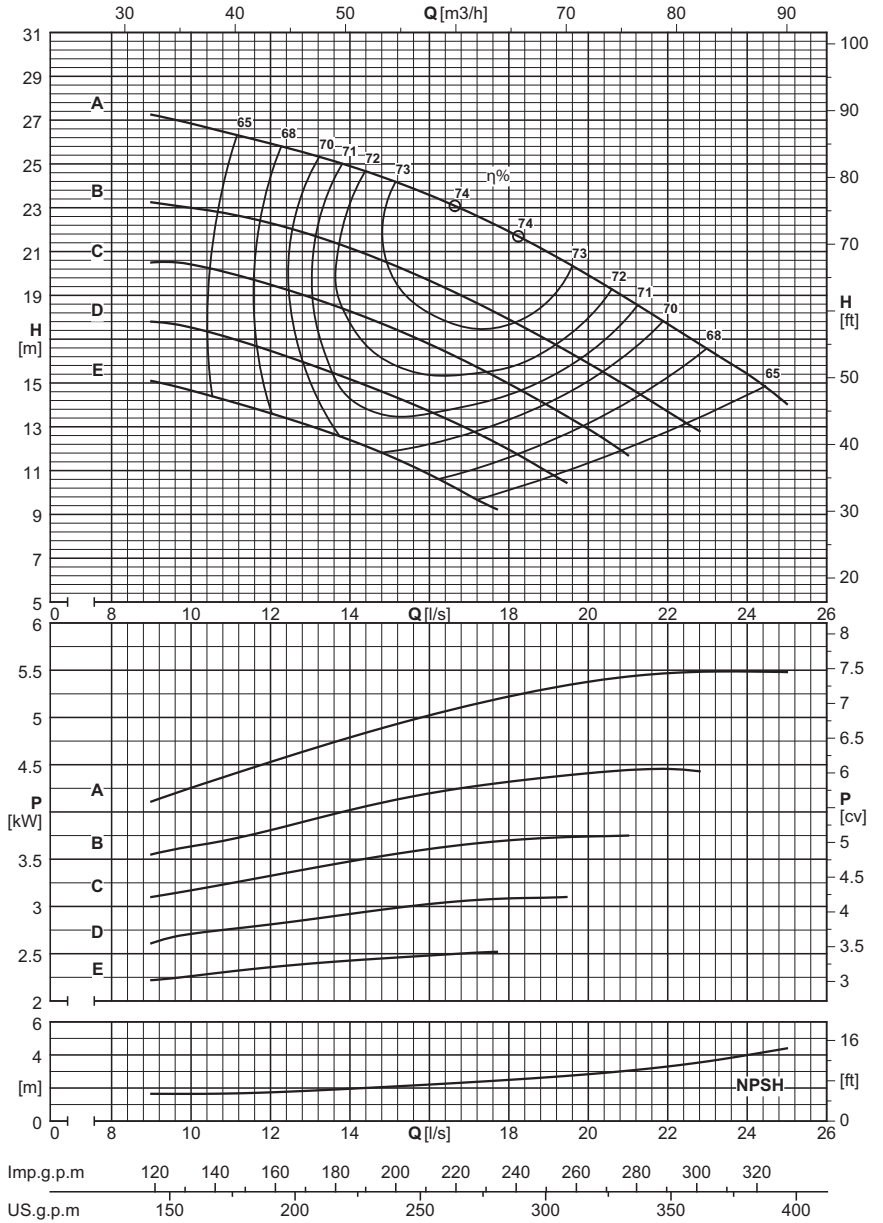

Capacity - Расход - Portata

Dna x DNm	Impeller type Тип раб. кол. / Girante tipo	[l/s]	0	10	11	12	13	14	15	16	17	18	19	20	21	22	23	24	25
		[m ³ /h]	0	36	39,6	43,2	46,8	50,4	54	57,6	61,2	64,8	68,4	72	75,6	79,2	82,8	86,4	90
		[l/min]	0	600	660	720	780	840	900	960	1020	1080	1140	1200	1260	1320	1380	1440	1500

PMX(S/H)T80/1

100x80	E	[m]	16,5	14,5	14,5	13,5	13	12,5	11	10	9,1								
100x80	E	[kW]		2,3	2,3	2,3	2,4	2,4	2,5	2,5	2,5	2,6							
100x80	D	[m]	18,5	17,5	17	16,5	16	15	14,5	13,5	13	12	11	10					
100x80	D	[kW]		2,7	2,7	2,9	2,9	2,9	3	3	3	3,1	3,1	3,2					
100x80	C	[m]	21,5	21	20	19,5	18,5	18,5	17,5	17	16	15,5	14	13,5	11,5				
100x80	C	[kW]		3,1	3,3	3,3	3,4	3,5	3,6	3,6	3,6	3,7	3,7	3,8	3,7				
100x80	B	[m]	24,5		23,5	22	22	21	20,5	20	19	18	17	16	14,5	13,5	12,5		
100x80	B	[kW]			3,7	3,8	3,8	4	4,2	4,1	4,3	4,4	4,3	4,4	4,4	4,4	4,5		
100x80	A	[m]	29,5		26	26,5	25,5	25,5	24	23,5	22,5	22	21	20	19	18	16,5	15,5	14,5
100x80	A	[kW]			4,5	4,4	4,6	4,8	4,9	5,1	5,2	5,2	5,3	5,4	5,5	5,6	5,4	5,4	5,5

NPSH

		[m]		1,7	1,7	1,7	1,8	2	2,1	2,2	2,3	2,5	2,7	2,8	3	3,3	3,6	4	4,4
--	--	-----	--	-----	-----	-----	-----	---	-----	-----	-----	-----	-----	-----	---	-----	-----	---	-----

Utilization field Область применения Campo di utilizzo ≥ 60% η		
Stage number: compatibly with the maximum pressure. Кол-во ступеней: совместимое с макс. давлением. Numero stadi: compatibilmente con la pressione massima di esercizio.		
Type Тип Tipo	MIN.	MAX.
PMXT	2	7
PMXST	2	7
PMXHT	5	10
NB. For two-stage pumps only, reduce efficiency by one point. Только для двухступенчатых насосов - снизить КПД на 1 единицу. Solamente per le pompe a due stadi, ridurre di un punto il rendimento.		

Wet moment of inertia J Момент инерции J мокрый Momento d'inerzia J bagnato J=¼PD ² - [kg m ²]		
Impeller type Тип раб. колеса Girante tipo	PMX(S/H)T80/1	For each additional stage Для каждой доп. ступени Per ogni stadio in più
Stainless steel Нержав. сталь Acciaio inox	0,0226	0,0186

Maximum permissible power Макс. допустимая мощность Massime potenze ammissibili	
Type Тип Tipo	N/n MAX.
PMXT	0,1
PMXST	0,1
PMXHT	0,1
For seal limits and calculation formulas of the maximum permissible powers, see technical data section. Ограничения по уплотнениям и формулы расчета макс. допустимой мощности - см. раздел "Технические данные". Per i limiti tenute e le formule di calcolo delle massime potenze ammissibili, vedere sezione dati tecnici.	

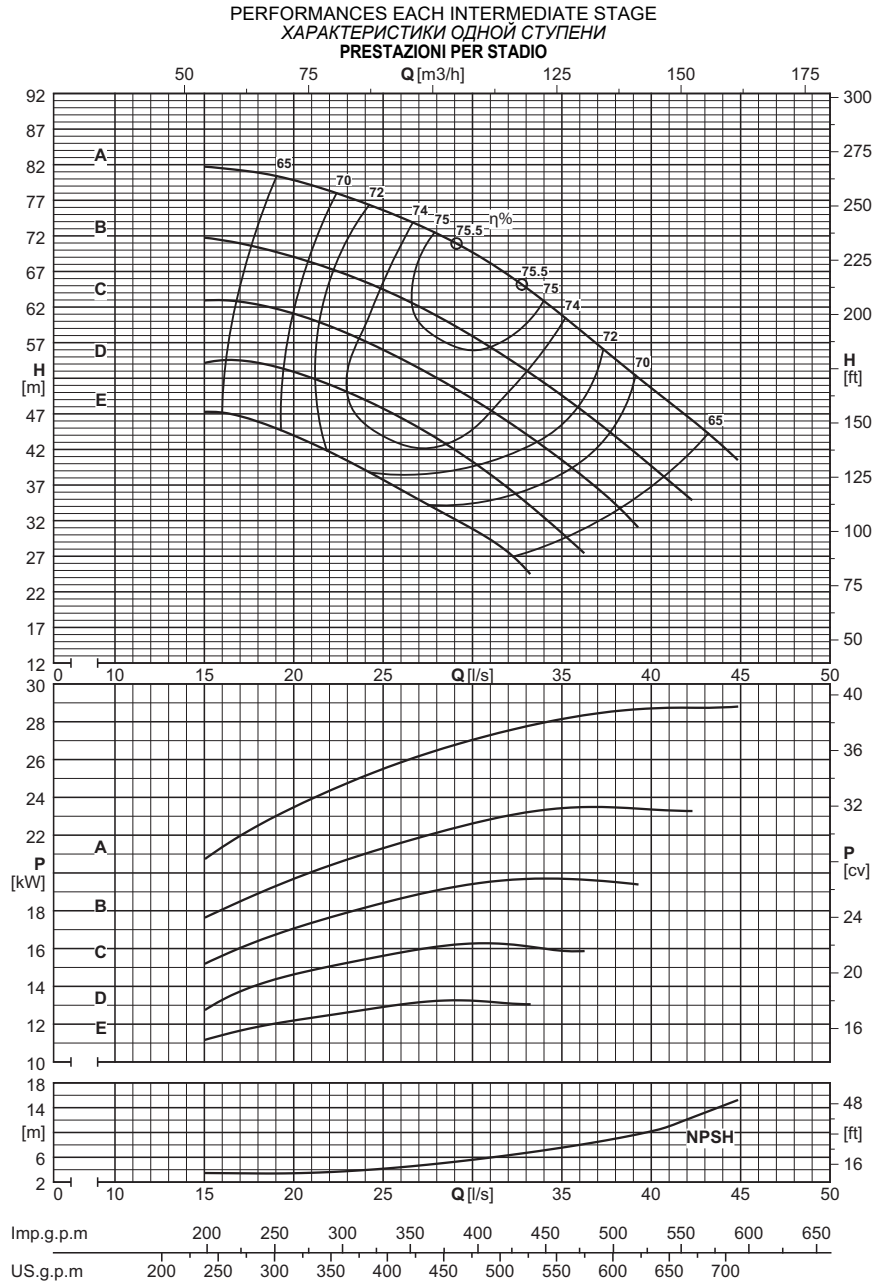

		Capacity - Расход - Portata																			
Dna x Dnm	Impeller type Тип раб. кол. Girante tipo	[l/s]	0	14	16	18	20	22	24	26	28	30	32	34	36	38	40	42	44		
		[m ³ /h]	0	50,4	57,6	64,8	72	79,2	86,4	93,6	100,8	108	115,2	122,4	129,6	136,8	144	151,2	158,4		
		[l/min]	0	840	960	1080	1200	1320	1440	1560	1680	1800	1920	2040	2160	2280	2400	2520	2640		
PMX(S/H)T80/1																					
100x80	E	[m]	49	51	47,5	46	44	41,5	40	36,5	33,5	30,5	27								
100x80	E	[kW]		10,4	11,4	11,9	12,3	12,6	12,9	13,2	13,1	13,1	13								
100x80	D	[m]	56	58	55	55	52	50	49	46,5	43,5	40,5	37	32,5							
100x80	D	[kW]		11,9	13,2	13,9	14,9	15	15,5	15,5	16	16,5	16,5	16,5							
100x80	C	[m]	65		64	61	61	58	57	55	52	49	46,5	42,5	39	34,5					
100x80	C	[kW]			15,5	16,5	17,5	18	18	18,5	19	19	20	19,5	20	19,5					
100x80	B	[m]	74		73	70	67	67	65	63	60	57	54	51	47,5	44	40,5	35	33,5		
100x80	B	[kW]			17,5	19	20	20,5	21	21,5	22	23	23	23,5	23	23,5	24	23	24		
100x80	A	[m]	88			81	79	76	77	74	71	70	66	62	59	54	50	47,5	43,5		
100x80	A	[kW]				22,5	23,5	25	25	26	26,5	26,5	27,5	29	28,5	28	28,5	30	29		
NPSH																					
		[m]		3,2	3,4	3,4	3,4	3,6	3,9	4,4	5	5,7	6,4	7,1	8,1	9	10,2	12,3	13,7		

Overall dimensions and weights
Общие габариты и вес
Dimensioni di ingombro e pesi

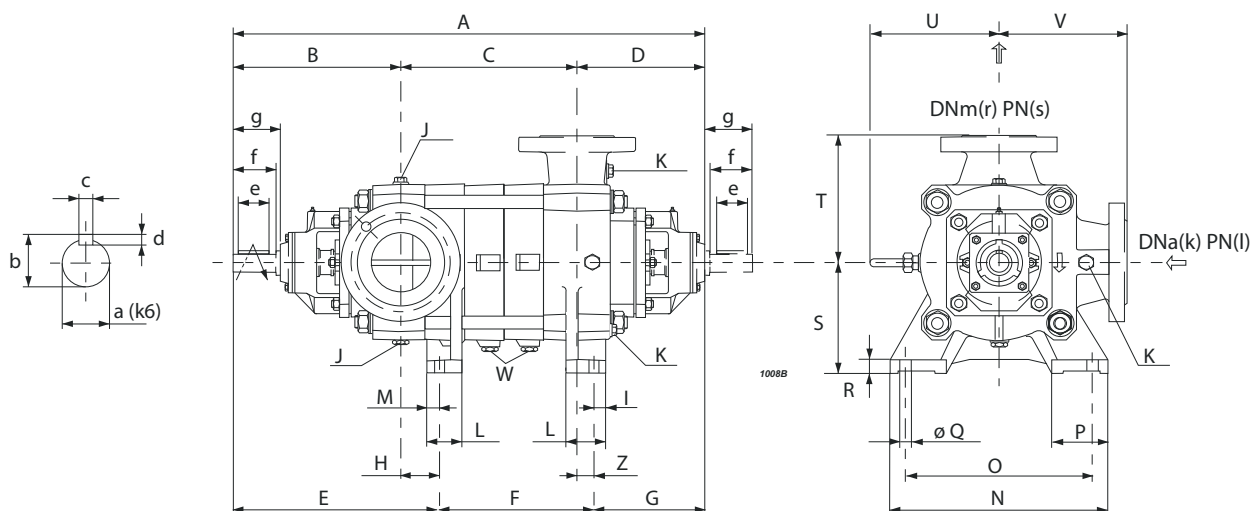

Series Серия Serie	Type Тип Tipo	A	B	C	D	E	F	G	H	S	T	U	V	Z	Weight Вес Peso
		[mm]													
PMX(S)T	80/2	805	360	171	274	422	138	245	61,5	200	245	258	245	29	196
PMX(S)T	80/3	875	360	241	274	422	208	245	61,5	200	245	258	245	29	218
PMX(S)T	80/4	945	360	311	274	422	278	245	61,5	200	245	258	245	29	241
PMX(S/H)T	80/5	1015	360	381	274	422	348	245	61,5	200	245	258	245	29	264
PMX(S/H)T	80/6	1085	360	451	274	422	418	245	61,5	200	245	258	245	29	287
PMX(S/H)T	80/7	1155	360	521	274	422	488	245	61,5	200	245	258	245	29	310
PMX(S/H)T	80/8	1225	360	591	274	422	558	245	61,5	200	245	258	245	29	333
PMX(S/H)T	80/9	1295	360	661	274	422	628	245	61,5	200	245	258	245	29	356
PMX(S/H)T	80/10	1365	360	731	274	422	698	245	61,5	200	245	258	245	29	379
PMX(S/H)T	80/11	1435	360	801	274	422	768	245	61,5	200	245	258	245	29	401
PMX(S/H)T	80/12	1505	360	871	274	422	838	245	61,5	200	245	258	245	29	424
PMX(S/H)T	80/13	1575	360	941	274	422	908	245	61,5	200	245	258	245	29	447
PMX(S/H)T	80/14	1645	360	1011	274	422	978	245	61,5	200	245	258	245	29	470
PMX(S/H)T	80/15	1715	360	1081	274	422	1048	245	61,5	200	245	258	245	29	493
PMX(S/H)T	80/16	1785	360	1151	274	422	1118	245	61,5	200	245	258	245	29	516

Foot dimensions Размеры ножек Dimensioni dei piedi							
I	L	M	N	O	P	Q	R
[mm]							
26	70	25	420	370	102	24	25

Shaft projection Выступ вала Sporgenza d'albero							
a	b	c	d	e	f	g	
[mm]							
35	38	10	8	70	90	104	

Flanges Фланцы Flange				
Type Тип Tipo	(k)	(l)	(r)	(s)
	DNa	PN	DNm	PN
	[mm]	[bar]	[mm]	[bar]
PMXT	100	25	80	40
PMXST	100	25	80	63
PMXHT	100	40	80	100

Plugs Пробки Tappi		
J	K	W
G1/2	G1/2	G1/4

COUPLINGS WITH STANDARDIZED ENCLOSED ELECTRIC MOTORS
 СОЕДИНЕНИЕ С НОРМАЛИЗОВАННЫМИ ЗАКРЫТЫМИ ЭЛЕКТРОДВИГАТЕЛЯМИ
 ACCORPIAMENTI CON MOTORI ELETTRICI CHIUSI NORMALIZZATI

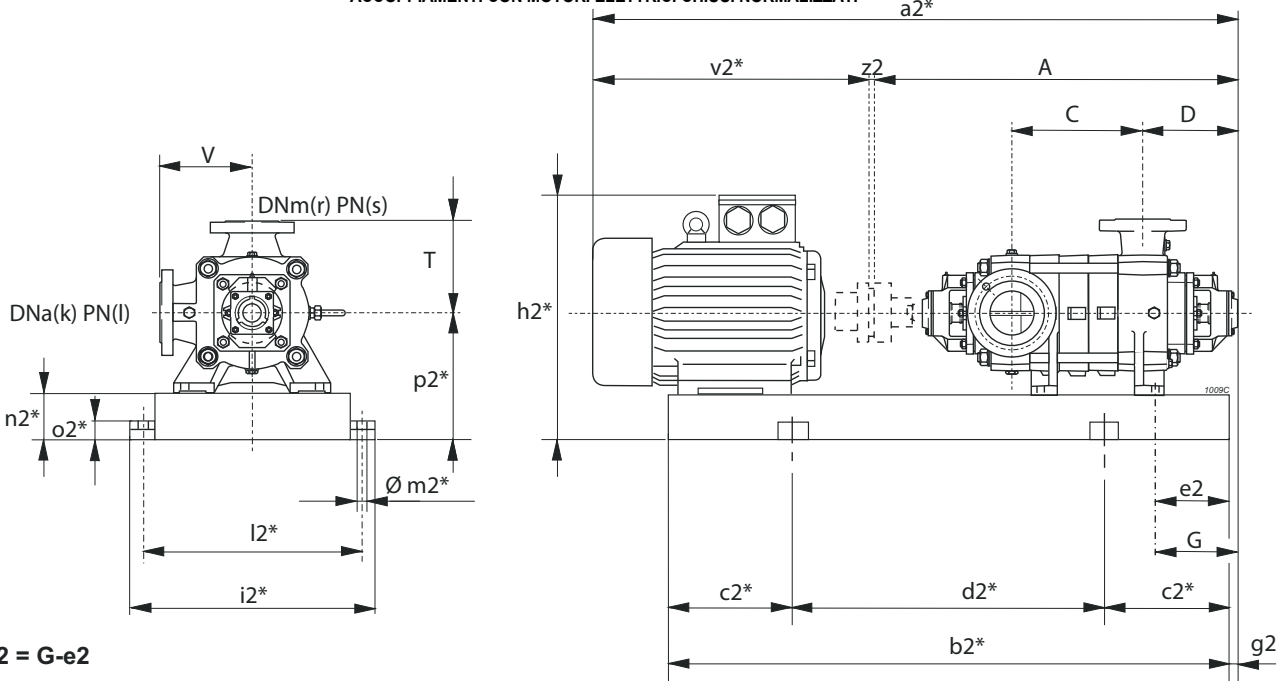

* Valori indicativi in funzione della marca di motore utilizzato - Indicatives values according to the type of motor installed - Приблизительные значения в зависимости от марки двигателя

Pump Насос Помпа		Motor Двигатель Motore		BGAM	A	C	D	G	T	V	a2*	b2*	c2*	d2*	e2	h2*	i2*	k	l	l2*	m2*	n2*	o2*	p2*	r	s	v2*	z2	Weight Вес Peso		
Series Серия Serie	Type Тип Tipo	[kW]	Size Размер Grand.	Type Тип Tipo	[mm]																										[kg]
PMX(S)T	80/2	18,5	160L	615/DN	804,5	170,5	274	245	245	245	1435,5	1151	200	751	50	551	550	100	(1)	500	20	100	42	300	80	(2)	627	4	377		
PMX(S)T	/2	22	180M	616/EN	804,5	170,5	274	245	245	245	1473,5	1161	200	761	50	570	550	100	(1)	500	20	100	42	300	80	(2)	665	4	418		
PMX(S)T	/2	30	200L	617/FN	804,5	170,5	274	245	245	245	1546,5	1234	200	834	50	600	550	100	(1)	500	20	100	42	300	80	(2)	738	4	472		
PMX(S)T	/2	37	200L	617/FN	804,5	170,5	274	245	245	245	1546,5	1234	200	834	50	600	550	100	(1)	500	20	100	42	300	80	(2)	738	4	500		
PMX(S)T	80/3	30	200L	618/FN	874,5	240,5	274	245	245	245	1616,5	1304	200	904	50	600	550	100	(1)	500	20	100	42	300	80	(2)	738	4	495		
PMX(S)T	/3	37	200L	618/FN	874,5	240,5	274	245	245	245	1616,5	1304	200	904	50	600	550	100	(1)	500	20	100	42	300	80	(2)	738	4	523		
PMX(S)T	/3	45	225M	619/FN	874,5	240,5	274	245	245	245	1653,5	1350	250	850	70	675	585	100	(1)	535	20	120	42	345	80	(2)	775	4	599		
PMX(S)T	/3	55	250M	620/GN	874,5	240,5	274	245	245	245	1748,5	1412	250	912	60	745	635	100	(1)	585	20	120	42	370	80	(2)	870	4	689		
PMX(S)T	80/4	37	200L	621/FN	944,5	310,5	274	245	245	245	1686,5	1374	250	874	50	600	550	100	(1)	500	20	100	42	300	80	(2)	738	4	545		
PMX(S)T	/4	45	225M	622/FN	944,5	310,5	274	245	245	245	1723,5	1420	250	920	70	675	585	100	(1)	535	20	120	42	345	80	(2)	775	4	622		
PMX(S)T	/4	55	250M	623/GN	944,5	310,5	274	245	245	245	1818,5	1482	250	982	60	745	635	100	(1)	585	20	120	42	370	80	(2)	870	4	712		
PMX(S)T	/4	75	280S	624/HN	944,5	310,5	274	245	245	245	1948,5	1559	250	1059	90	815	695	100	(1)	645	20	140	42	420	80	(2)	1000	4	934		
PMX(S)T	/4	90	280M	652/HN	944,5	310,5	274	245	245	245	1999,5	1610	250	1110	90	815	695	100	(1)	645	20	140	42	420	80	(2)	1051	4	1063		
PMX(S/H)T	80/5	45	225M	625/FN	1014,5	380,5	274	245	245	245	1793,5	1490	250	990	70	675	585	100	(1)	535	20	120	42	345	80	(2)	775	4	645		
PMX(S/H)T	/5	55	250M	626/GN	1014,5	380,5	274	245	245	245	1888,5	1552	250	1052	60	745	635	100	(1)	585	20	120	42	370	80	(2)	870	4	735		
PMX(S/H)T	/5	75	280S	627/HN	1014,5	380,5	274	245	245	245	2018,5	1629	250	1129	90	815	695	100	(1)	645	20	140	42	420	80	(2)	1000	4	957		
PMX(S/H)T	/5	90	280M	628/HN	1014,5	380,5	274	245	245	245	2069,5	1680	300	1080	90	815	695	100	(1)	645	20	140	42	420	80	(2)	1051	4	1086		
PMX(S/H)T	80/6	55	250M	629/GN	1084,5	450,5	274	245	245	245	1958,5	1622	250	1122	60	745	635	100	(1)	585	20	120	42	370	80	(2)	870	4	758		
PMX(S/H)T	/6	75	280S	630/HN	1084,5	450,5	274	245	245	245	2088,5	1699	300	1099	90	815	695	100	(1)	645	20	140	42	420	80	(2)	1000	4	980		
PMX(S/H)T	/6	90	280M	631/HN	1084,5	450,5	274	245	245	245	2139,5	1750	300	1150	90	815	695	100	(1)	645	20	140	42	420	80	(2)	1051	4	1109		
PMX(S/H)T	/6	110	315S	632/IN	1084,5	450,5	274	245	245	245	2269,5	1796	300	1196	90	815	780	100	(1)	730	22	160	50	475	80	(2)	1181	4	1402		
PMX(S/H)T	80/7	55	250M	633/GN	1154,5	520,5	274	245	245	245	2028,5	1692	300	1092	60	745	635	100	(1)	585	20	120	42	370	80	(2)	870	4	781		
PMX(S/H)T	/7	75	280S	634/HN	1154,5	520,5	274	245	245	245	2158,5	1769	300	1169	90	815	695	100	(1)	645	20	140	42	420	80	(2)	1000	4	1004		
PMX(S/H)T	/7	90	280M	635/HN	1154,5	520,5	274	245	245	245	2209,5	1820	300	1220	90	815	695	100	(1)	645	20	140	42	420	80	(2)	1051	4	1132		
PMX(S/H)T	/7	110	315S	636/IN	1154,5	520,5	274	245	245	245	2339,5	1866	300	1266	90	815	780	100	(1)	730	22	160	50	475	80	(2)	1181	4	1426		
PMX(S/H)T	/7	132	315M	637/IN	1154,5	520,5	274	245	245	245	2449,5	1925	300	1325	90	815	780	100	(1)	730	22	160	50	475	80	(2)	1291	4	1500		
PMX(S/H)T	80/8	75	280S	638/HN	1224,5	590,5	274	245	245	245	2228,5	1839	300	1239	90	815	695	100	(1)	645	20	140	42	420	80	(2)	1000	4	1027		
PMX(S/H)T	/8	90	280M	639/HN	1224,5	590,5	274	245	245	245	2279,5	1890	300	1290	90	815	695	100	(1)	645	20	140	42	420	80	(2)	1051	4	1156		
PMX(S/H)T	/8	110	315S	640/IN	1224,5	590,5	274	245	245	245	2409,5	1936	300	1336	90	815	780	100	(1)	730	22	160	50	475	80	(2)	1181	4	1449		

BGAM = Base and coupling
 * = Indicatives values according to the type of motor installed.
 ○ Motor in IE4 efficiency class according to EU REGULATION 2019/1781. Available in other efficiency classes for non-EU markets.

BGAMA = Рама и муфта
 * = Приблизит. значения в зависимости от марки двигателя.
 ○ Двигатель класса эффективности IE4 в соответствии с РЕГЛАМЕНТОМ ЕС 2019/1781. Имеются варианты в других классах эффективности для рынков за пределами ЕС.

BGAM = Base giunto e coprigiunto
 * = Valori indicativi in funzione della marca di motore utilizzato.
 ○ Motore in classe di efficienza IE4 in conformità al REGOLAMENTO UE2019/1781. Disponibili in altre classi di efficienza per mercati extra UE.

(1) PMXT=25 bar PMXST=25 bar PMXHT=40 bar
 (2) PMXT=40 bar PMXST=63 bar PMXHT=100 bar

(1) PMXT=25 бар PMXST=25 бар PMXHT=40 бар
 (2) PMXT=40 бар PMXST=63 бар PMXHT=100 бар

(1) PMXT=25 бар PMXST=25 бар PMXHT=40 бар
 (2) PMXT=40 бар PMXST=63 бар PMXHT=100 бар

Selection - dimensions and weights for base mounted electric pumps
 Подбор - заготовки и вес электронасосов на раме
 Selezione - dimensioni e pesi elettropompe su base

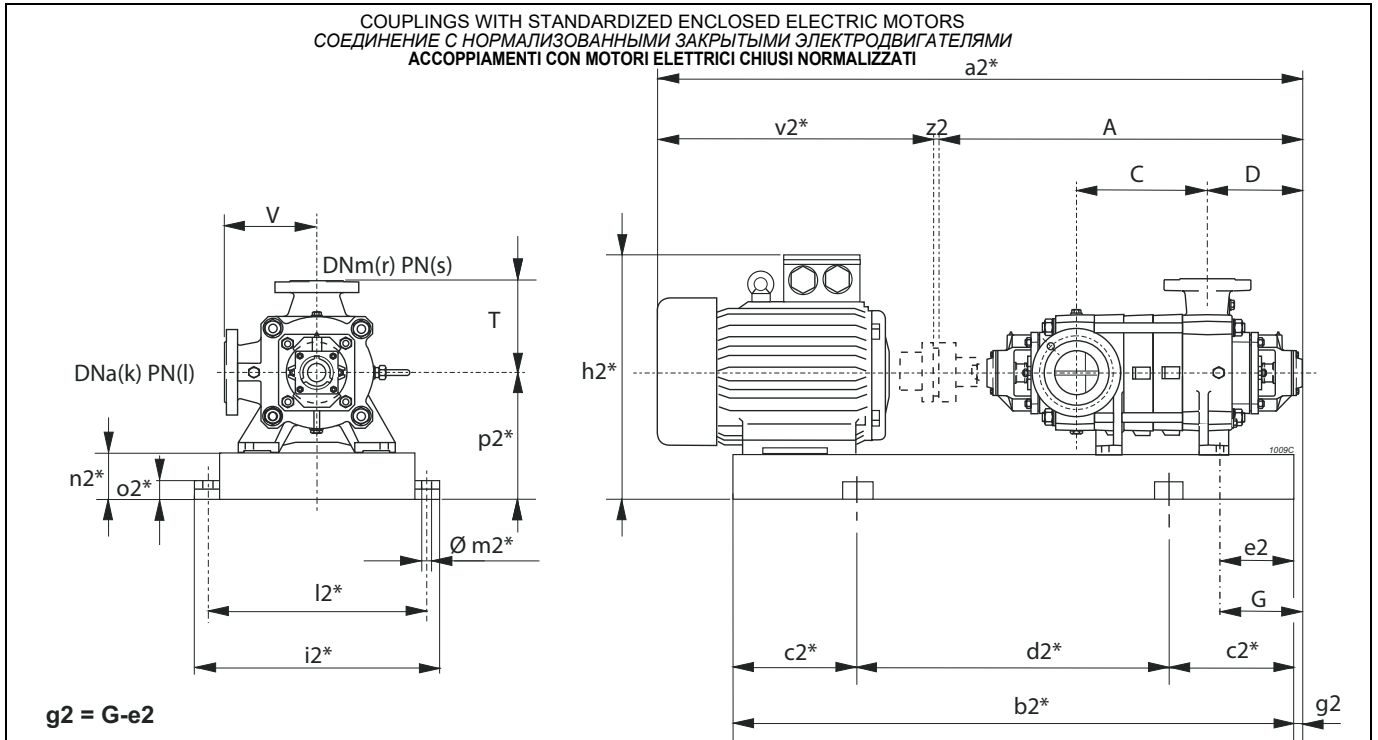

* Valori indicativi in funzione della marca di motore utilizzato - Indicatives values according to the type of motor installed - Приблизительные значения в зависимости от марки двигателя

Pump Насос Помпа	Motor Двигатель Motore	BGAM	A	C	D	G	T	V	a2*	b2*	c2*	d2*	e2	h2*	i2*	k	l	l2*	m2*	n2*	o2*	p2*	r	s	v2*	z2	Weight Вес Peso		
Series Серия Serie	Type Тип Tipo	[kW]	Size Размер Grand.	Type Тип Tipo	[mm]																				[kg]				
PMX(S/H)T	/8	132	315M	641/IN	1224,5	590,5	274	245	245	245	2519,5	2046	350	1346	90	1030	780	100	(1)	730	22	160	50	475	80	(2)	1291	4	1525
PMX(S/H)T	/8	160	315L	641/IN	1224,5	590,5	274	245	245	245	2519,5	2046	350	1346	90	1030	780	100	(1)	730	22	160	50	475	80	(2)	1291	4	1603
PMX(S/H)T	/8	200	315L	642/IE4/LQ	1224,5	590,5	274	245	245	245	2609,5	2136	350	1436	198	1030	780	100	(1)	730	22	160	50	475	80	(2)	1381	4	1719
PMX(S/H)T	80/9	75	280S	643/IN	1294,5	660,5	274	245	245	245	2298,5	1909	300	1309	90	815	695	100	(1)	645	20	140	42	420	80	(2)	1000	4	1050
PMX(S/H)T	/9	90	280M	644/IN	1294,5	660,5	274	245	245	245	2349,5	1960	350	1260	90	815	695	100	(1)	645	20	140	42	420	80	(2)	1051	4	1179
PMX(S/H)T	/9	110	315S	645/IN	1294,5	660,5	274	245	245	245	2479,5	2006	350	1306	90	1030	780	100	(1)	730	22	160	50	475	80	(2)	1181	4	1473
PMX(S/H)T	/9	132	315M	646/IN	1294,5	660,5	274	245	245	245	2589,5	2065	350	1365	90	1030	780	100	(1)	730	22	160	50	475	80	(2)	1291	4	1547
PMX(S/H)T	/9	160	315L	647/LQ	1294,5	660,5	274	245	245	245	2589,5	2116	350	1416	90	1030	780	100	(1)	730	22	160	50	475	80	(2)	1291	4	1632
PMX(S/H)T	/9	200	315L	647/IE4/LQ	1294,5	660,5	274	245	245	245	2679,5	2206	350	1506	198	1030	780	100	(1)	730	22	160	50	475	80	(2)	1381	4	1742
PMX(S/H)T	80/10	90	280M	648/IN	1364,5	730,5	274	245	245	245	2419,5	2030	350	1330	90	815	695	100	(1)	645	20	140	42	420	80	(2)	1051	4	1202
PMX(S/H)T	/10	110	315S	649/IN	1364,5	730,5	274	245	245	245	2549,5	2076	350	1376	90	1030	780	100	(1)	730	22	160	50	475	80	(2)	1181	4	1497
PMX(S/H)T	/10	132	315M	650/IN	1364,5	730,5	274	245	245	245	2659,5	2186	350	1486	90	1030	780	100	(1)	730	22	160	50	475	80	(2)	1291	4	1573
PMX(S/H)T	/10	160	315L	650/IN	1364,5	730,5	274	245	245	245	2659,5	2186	350	1486	90	1030	780	100	(1)	730	22	160	50	475	80	(2)	1291	4	1651
PMX(S/H)T	/10	200	315L	651/IE4/LQ	1364,5	730,5	274	245	245	245	2749,5	2276	400	1476	198	1030	780	100	(1)	730	22	160	50	475	80	(2)	1381	4	1765
PMX(S/H)T	80/11	90	280M	6648/IN	1434,5	800,5	274	245	245	245	2489,5	2100	350	1400	90	815	695	100	(1)	645	20	140	42	420	80	(2)	1051	4	1225
PMX(S/H)T	/11	110	315S	1200/IS	1434,5	800,5	274	245	245	245	2619,5	2146	350	1446	90	1030	780	100	(1)	730	22	160	50	475	80	(2)	1181	4	1520
PMX(S/H)T	/11	132	315M	1201/IN	1434,5	800,5	274	245	245	245	2729,5	2256	400	1456	90	1030	780	100	(1)	730	22	160	50	475	80	(2)	1291	4	1596
PMX(S/H)T	/11	160	315L	1201/IN	1434,5	800,5	274	245	245	245	2729,5	2256	400	1456	90	1030	780	100	(1)	730	22	160	50	475	80	(2)	1291	4	1674
PMX(S/H)T	/11	200	315L	1202/IE4/LQ	1434,5	800,5	274	245	245	245	2819,5	2346	400	1546	198	1030	780	100	(1)	730	22	160	50	475	80	(2)	1381	4	1789
PMX(S/H)T	80/12	110	315S	1203/IN	1504,5	870,5	274	245	245	245	2689,5	2216	350	1516	90	1030	780	100	(1)	730	22	160	50	475	80	(2)	1181	4	1544
PMX(S/H)T	/12	132	315M	1204/IN	1504,5	870,5	274	245	245	245	2799,5	2326	400	1526	90	1030	780	100	(1)	730	22	160	50	475	80	(2)	1291	4	1620
PMX(S/H)T	/12	160	315L	1204/IN	1504,5	870,5	274	245	245	245	2799,5	2326	400	1526	90	1030	780	100	(1)	730	22	160	50	475	80	(2)	1291	4	1698
PMX(S/H)T	/12	200	315L	1205/IE4/LQ	1504,5	870,5	274	245	245	245	2889,5	2416	400	1616	198	1030	780	100	(1)	730	22	160	50	475	80	(2)	1381	4	1812
PMX(S/H)T	/12	250	355M	1206/LQ	1504,5	870,5	274	245	245	245	3034,5	2400	400	1600	110	1136	880	100	(1)	830	22	180	50	535	80	(2)	1526	4	2256
PMX(H)T	80/13	110	315S	2203/IN	1574,5	940,5	274	245	245	245	2759,5	2286	400	1486	90	1030	780	100	(1)	730	22	160	50	475	80	(2)	1181	4	1567
PMX(H)T	/13	132	315M	1207/IN	1574,5	940,5	274	245	245	245	2869,5	2396	400	1596	90	1030	780	100	(1)	730	22	160	50	475	80	(2)	1291	4	1644
PMX(H)T	/13	160	315L	1207/IN	1574,5	940,5	274	245	245	245	2869,5	2396	400	1596	90	1030	780	100	(1)	730	22	160	50	475	80	(2)	1291	4	1722
PMX(H)T	/13	200	315L	1208/IE4/LQ	1574,5	940,5	274	245	245	245	2959,5	2486	400	1686	198	1030	780	100	(1)	730	22	160	50	475	80	(2)	1381	4	1835
PMX(H)T	/13	250	355M	1209/LQ	1574,5	940,5	274	245	245	245	3104,5	2470	400	1670	110	1136	880	100	(1)	830	22	180	50	535	80	(2)	1526	4	2280

BGAM = Base and coupling

* = Indicatives values according to the type of motor installed.

○ Motor in IE4 efficiency class according to EU REGULATION 2019/1781. Available in other efficiency classes for non-EU markets.

BGAMA = Рама и муфта

* = Приблизит. значения в зависимости от марки двигателя.

○ Двигатель класса эффективности IE4 в соответствии с РЕГЛАМЕНТОМ ЕС 2019/1781. Имеются варианты в других классах эффективности для рынков за пределами ЕС.

BGAM = Base giunto e coprigiunto

* = Valori indicativi in funzione della marca di motore utilizzato.

○ Motore in classe di efficienza IE4 in conformità al REGOLAMENTO UE2019/1781. Disponibili in altre classi di efficienza per mercati extra UE.

- (1) PMXT=25 bar PMXST=25 bar PMXHT=40 bar
 (2) PMXT=40 bar PMXST=63 bar PMXHT=100 bar

- (1) PMXT=25 бар PMXST=25 бар PMXHT=40 бар
 (2) PMXT=40 бар PMXST=63 бар PMXHT=100 бар

- (1) PMXT=25 bar PMXST=25 bar PMXHT=40 bar
 (2) PMXT=40 bar PMXST=63 bar PMXHT=100 bar

COUPLINGS WITH STANDARDIZED ENCLOSED ELECTRIC MOTORS
 СОЕДИНЕНИЕ С НОРМАЛИЗОВАННЫМИ ЗАКРЫТЫМИ ЭЛЕКТРОДВИГАТЕЛЯМИ
 ACCOPPIAMENTI CON MOTORI ELETTRICI CHIUSI NORMALIZZATI

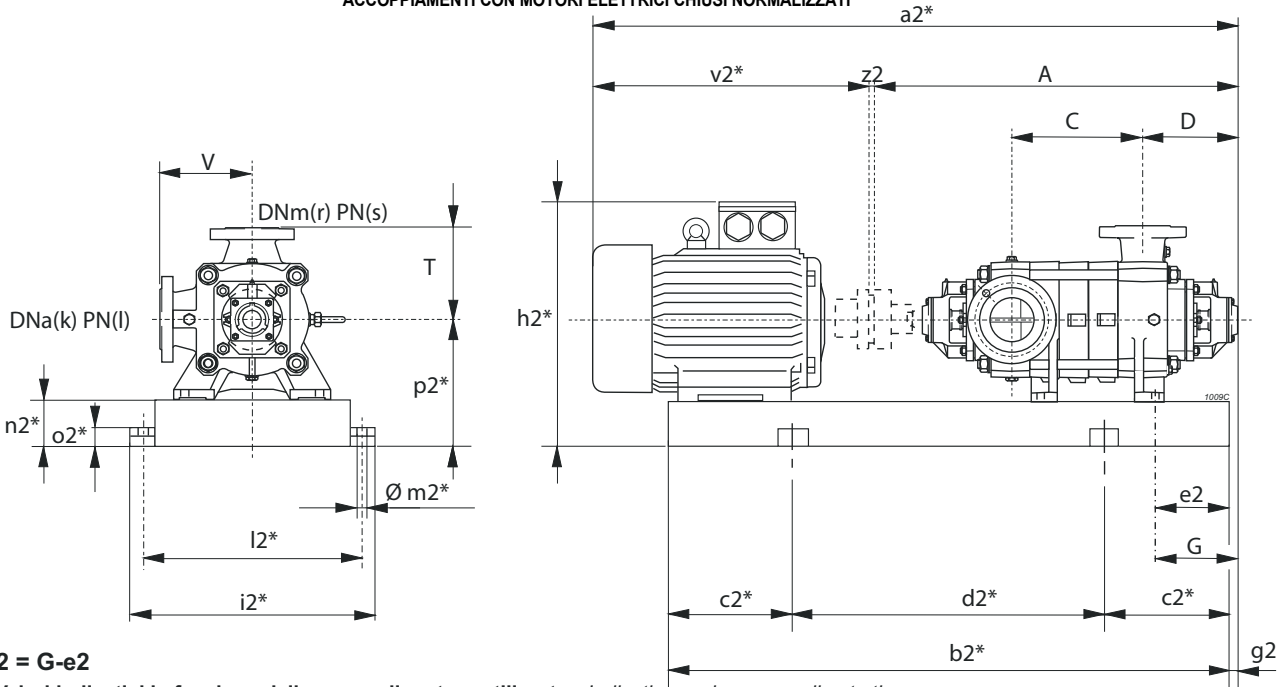

$g2 = G - e2$

* Valori indicativi in funzione della marca di motore utilizzato - Indicatives values according to the type of motor installed - Приблизительные значения в зависимости от марки двигателя

Pump Насос Помпа		Motor Двигатель Motore		BGAM	A	C	D	G	T	V	a2*	b2*	c2*	d2*	e2	h2*	i2*	k	l	l2*	m2*	n2*	o2*	p2*	r	s	v2*	z2	Weight Вес Peso
Series Серия Serie	Type Тип Tipo	[kW]	Size Размер Grand.	Type Тип Tipo	[mm]																								[kg]
PMX(H)T	80/14	132	315M	1210/IN	1644,5	1010,5	274	245	245	245	2939,5	2466	400	1666	90	1030	780	100	(1)	730	22	160	50	475	80	(2)	1291	4	1667
PMX(H)T	/14	160	315L	1210/IN	1644,5	1010,5	274	245	245	245	2939,5	2466	400	1666	90	1030	780	100	(1)	730	22	160	50	475	80	(2)	1291	4	1745
PMX(H)T	/14	200	315L	1211/IE4/LQ	1644,5	1010,5	274	245	245	245	3029,5	2556	450	1656	198	1030	780	100	(1)	730	22	160	50	475	80	(2)	1381	4	1858
PMX(H)T	/14	250	355M	1212/LQ	1644,5	1010,5	274	245	245	245	3174,5	2540	400	1740	110	1136	880	100	(1)	830	22	180	50	535	80	(2)	1526	4	2304
PMX(H)T	80/15	132	315M	1213/IN	1714,5	1080,5	274	245	245	245	3009,5	2536	400	1736	90	1030	780	100	(1)	730	22	160	50	475	80	(2)	1291	4	1691
PMX(H)T	/15	160	315L	1213/IN	1714,5	1080,5	274	245	245	245	3009,5	2536	400	1736	90	1030	780	100	(1)	730	22	160	50	475	80	(2)	1291	4	1769
PMX(H)T	/15	200	315L	1214/IE4/LQ	1714,5	1080,5	274	245	245	245	3099,5	2626	450	2726	198	1030	780	100	(1)	730	22	160	50	475	80	(2)	1381	4	1881
PMX(H)T	/15	250	355M	1215/LQ	1714,5	1080,5	274	245	245	245	3244,5	2680	450	1780	110	1136	880	100	(1)	830	22	180	50	535	80	(2)	1526	4	2331
PMX(H)T	/15	280	355L	1215/LQ	1714,5	1080,5	274	245	245	245	3244,5	2680	450	1780	110	1136	880	100	(1)	830	22	180	50	535	80	(2)	1526	4	2456
PMX(H)T	80/16	132	315M	1216/IN	1784,5	1150,5	274	245	245	245	3079,5	2606	450	1706	90	1030	780	100	(1)	730	22	160	50	475	80	(2)	1291	4	1714
PMX(H)T	/16	160	315L	1216/IN	1784,5	1150,5	274	245	245	245	3079,5	2606	450	1706	90	1030	780	100	(1)	730	22	160	50	475	80	(2)	1291	4	1792
PMX(H)T	/16	200	315L	1217/IE4/LQ	1784,5	1150,5	274	245	245	245	3169,5	2696	450	2796	198	1030	780	100	(1)	730	22	160	50	475	80	(2)	1381	4	1904
PMX(H)T	/16	250	355M	1218/LQ	1784,5	1150,5	274	245	245	245	3314,5	2750	450	1850	110	1136	880	100	(1)	830	22	180	50	535	80	(2)	1526	4	2357
PMX(H)T	/16	315	355L	1218/MQ	1784,5	1150,5	274	245	245	245	3314,5	2750	450	1850	110	1136	880	100	(1)	830	22	180	50	535	80	(2)	1526	4	2486

BGAM = Base and coupling

* = Indicatives values according to the type of motor installed.

○ Motor in IE4 efficiency class according to EU REGULATION 2019/1781. Available in other efficiency classes for non-EU markets.

- (1) PMXT=25 bar PMXST=25 bar PMXHT=40 bar
- (2) PMXT=40 bar PMXST=63 bar PMXHT=100 bar

BGAMA = Рама и муфта

* = Приблизит. значения в зависимости от марки двигателя.

○ Двигатель класса эффективности IE4 в соответствии с РЕГЛАМЕНТОМ ЕС 2019/1781. Имеются варианты в других классах эффективности для рынков за пределами ЕС.

- (1) PMXT=25 бар PMXST=25 бар PMXHT=40 бар
- (2) PMXT=40 бар PMXST=63 бар PMXHT=100 бар

BGAM = Base giunto e coprigiunto

* = Valori indicativi in funzione della marca di motore utilizzato.

○ Motore in classe di efficienza IE4 in conformità al REGOLAMENTO UE2019/1781. Disponibili in altre classi di efficienza per mercati extra UE.

- (1) PMXT=25 bar PMXST=25 bar PMXHT=40 bar
- (2) PMXT=40 bar PMXST=63 bar PMXHT=100 bar

Selection - dimensions and weights for base mounted electric pumps
 Подбор - габариты и вес электронасосов на раме
 Selezione - dimensioni e pesi elettropompe su base

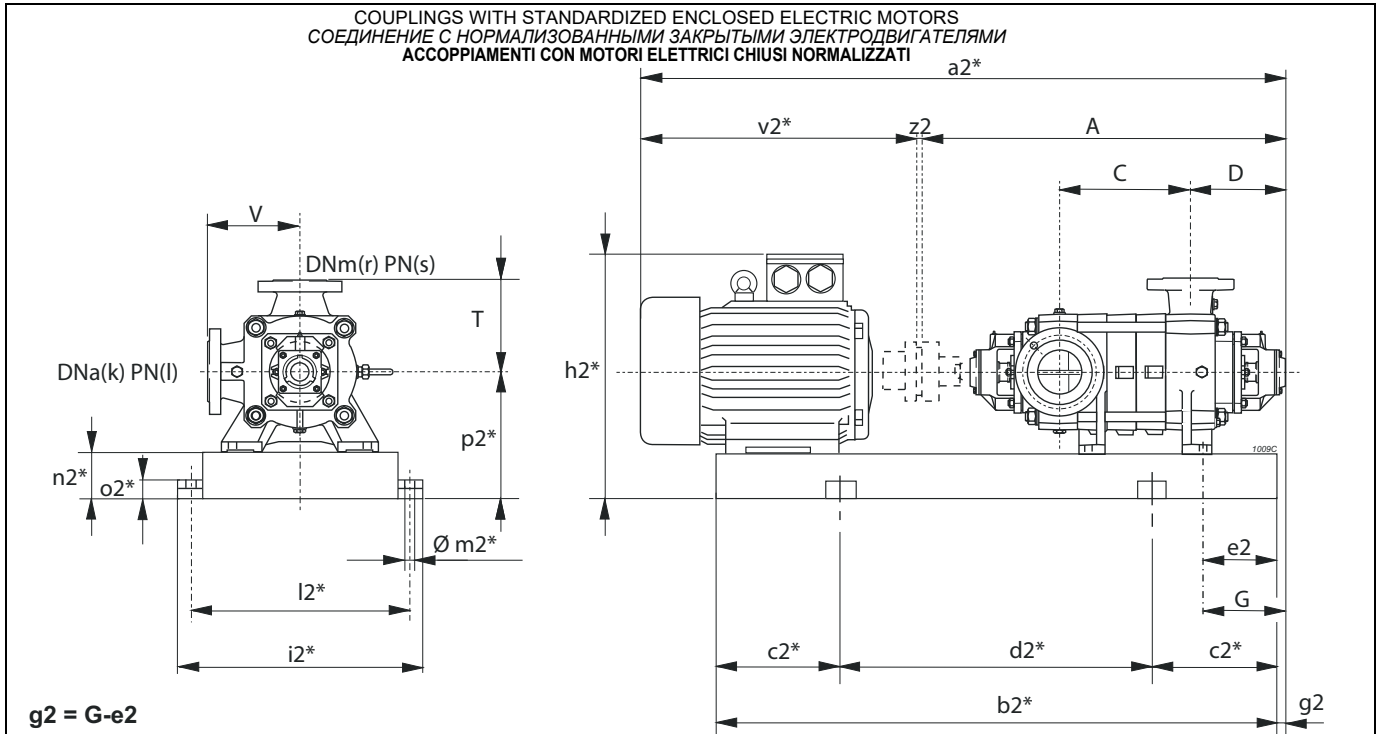

g2 = G-e2
 * Valori indicativi in funzione della marca di motore utilizzato - Indicatives values according to the type of motor installed - Приблизительные значения в зависимости от марки двигателя

Pump Насос Помпа		Motor Двигатель Motore		BGAM	A	C	D	G	T	V	a2*	b2*	c2*	d2*	e2	h2*	i2*	k	l	l2*	m2*	n2*	o2*	p2*	r	s	v2*	z2	Weight Вес Peso			
Series Серия Serie	Type Тип Tipo	[kW]	Size Размер Grand.	Type Тип Tipo	[mm]																											[kg]
PMX(S)T	80/2	2,2	100L	655/CN	804,5	170,5	274	245	245	245	1213,5	915	150	615	50	450	550	100	(1)	500	20	100	42	300	80	(2)	405	4	257			
PMX(S)T	/2	3	100L	655/CN	804,5	170,5	274	245	245	245	1213,5	915	150	615	50	450	550	100	(1)	500	20	100	42	300	80	(2)	405	4	261			
PMX(S)T	/2	4	112M	656/CN	804,5	170,5	274	245	245	245	1248,5	922	150	622	50	472	550	100	(1)	500	20	100	42	300	80	(2)	440	4	262			
PMX(S)T	/2	5,5	132S	657/DN	804,5	170,5	274	245	245	245	1263,5	963	150	663	50	492	550	100	(1)	500	20	100	42	300	80	(2)	455	4	272			
PMX(S)T	80/3	3	100L	6655/CN	874,5	240,5	274	245	245	245	1283,5	985	150	685	50	450	550	100	(1)	500	20	100	42	300	80	(2)	405	4	283			
PMX(S)T	/3	4	112M	658/CN	874,5	240,5	274	245	245	245	1318,5	992	150	692	50	472	550	100	(1)	500	20	100	42	300	80	(2)	440	4	285			
PMX(S)T	/3	5,5	132S	659/DN	874,5	240,5	274	245	245	245	1333,5	1033	150	733	50	492	550	100	(1)	500	20	100	42	300	80	(2)	455	4	294			
PMX(S)T	/3	7,5	132M	660/DN	874,5	240,5	274	245	245	245	1368,5	1071	200	671	50	492	550	100	(1)	500	20	100	42	300	80	(2)	490	4	304			
PMX(S)T	80/4	4	112M	6658/CN	944,5	310,5	274	245	245	245	1388,5	1062	200	662	50	472	550	100	(1)	500	20	100	42	300	80	(2)	440	4	307			
PMX(S)T	/4	5,5	132S	661/DN	944,5	310,5	274	245	245	245	1403,5	1103	200	703	50	492	550	100	(1)	500	20	100	42	300	80	(2)	455	4	317			
PMX(S)T	/4	7,5	132M	662/DN	944,5	310,5	274	245	245	245	1438,5	1141	200	741	50	492	550	100	(1)	500	20	100	42	300	80	(2)	490	4	326			
PMX(S)T	/4	11	160M	663/EN	944,5	310,5	274	245	245	245	1575,5	1247	200	847	50	551	550	100	(1)	500	20	100	42	300	80	(2)	627	4	412			
PMX(S/H)T	80/5	5,5	132S	664/DN	1014,5	380,5	274	245	245	245	1473,5	1173	200	773	50	492	550	100	(1)	500	20	100	42	300	80	(2)	455	4	339			
PMX(S/H)T	/5	7,5	132M	665/DN	1014,5	380,5	274	245	245	245	1508,5	1211	200	811	50	492	550	100	(1)	500	20	100	42	300	80	(2)	490	4	349			
PMX(S/H)T	/5	11	160M	666/EN	1014,5	380,5	274	245	245	245	1645,5	1317	200	917	50	551	550	100	(1)	500	20	100	42	300	80	(2)	627	4	435			
PMX(S/H)T	/5	15	160L	667/EN	1014,5	380,5	274	245	245	245	1645,5	1361	250	861	50	551	550	100	(1)	500	20	100	42	300	80	(2)	627	4	448			
PMX(S/H)T	80/6	7,5	132M	668/DN	1084,5	450,5	274	245	245	245	1578,5	1281	200	881	50	492	550	100	(1)	500	20	100	42	300	80	(2)	490	4	371			
PMX(S/H)T	/6	11	160M	669/EN	1084,5	450,5	274	245	245	245	1715,5	1387	250	887	50	551	550	100	(1)	500	20	100	42	300	80	(2)	627	4	457			
PMX(S/H)T	/6	15	160L	670/EN	1084,5	450,5	274	245	245	245	1715,5	1431	250	931	50	551	550	100	(1)	500	20	100	42	300	80	(2)	627	4	470			
PMX(S/H)T	80/7	7,5	132M	671/DN	1154,5	520,5	274	245	245	245	1648,5	1351	250	851	50	492	550	100	(1)	500	20	100	42	300	80	(2)	490	4	394			
PMX(S/H)T	/7	11	160M	672/EN	1154,5	520,5	274	245	245	245	1785,5	1457	250	957	50	551	550	100	(1)	500	20	100	42	300	80	(2)	627	4	480			
PMX(S/H)T	/7	15	160L	673/EN	1154,5	520,5	274	245	245	245	1785,5	1501	250	1001	50	551	550	100	(1)	500	20	100	42	300	80	(2)	627	4	493			
PMX(S/H)T	/7	18,5	180M	674/FN	1154,5	520,5	274	245	245	245	1823,5	1511	250	1011	50	570	550	100	(1)	500	20	100	42	300	80	(2)	665	4	530			
PMX(S/H)T	80/8	11	160M	676/EN	1224,5	590,5	274	245	245	245	1855,5	1527	250	1027	50	551	550	100	(1)	500	20	100	42	300	80	(2)	627	4	502			
PMX(S/H)T	/8	15	160L	677/EN	1224,5	590,5	274	245	245	245	1855,5	1571	250	1071	50	551	550	100	(1)	500	20	100	42	300	80	(2)	627	4	515			
PMX(S/H)T	/8	18,5	180M	678/FN	1224,5	590,5	274	245	245	245	1893,5	1581	250	1081	50	570	550	100	(1)	500	20	100	42	300	80	(2)	665	4	552			
PMX(S/H)T	80/9	11	160M	679/EN	1294,5	660,5	274	245	245	245	1925,5	1597	250	1097	50	551	550	100	(1)	500	20	100	42	300	80	(2)	627	4	525			
PMX(S/H)T	/9	15	160L	680/EN	1294,5	660,5	274	245	245	245	1925,5	1641	250	1141	50	551	550	100	(1)	500	20	100	42	300	80	(2)	627	4	537			
PMX(S/H)T	/9	18,5	180M	681/FN	1294,5	660,5	274	245	245	245	1963,5	1651	300	1051	50	570	550	100	(1)	500	20	100	42	300	80	(2)	665	4	575			
PMX(S/H)T	/9	22	180L	682/FN	1294,5	660,5	274	245	245	245	2003,5	1689	300	1089	50	570	550	100	(1)	500	20	100	42	300	80	(2)	705	4	596			
PMX(S/H)T	80/10	11	160M	683/EN	1364,5	730,5	274	245	245	245	1995,5	1667	300	1067	50	551	550	100	(1)	500	20	100	42	300	80	(2)	627	4	547			
PMX(S/H)T	/10	15	160L	684/EN	1364,5	730,5	274	245	245	245	1995,5	1711	300	1111	50	551	550	100	(1)	500	20	100	42	300	80	(2)	627	4	560			
PMX(S/H)T	/10	18,5	180M	685/FN	1364,5	730,5	274	245	245	245	2033,5	1721	300	1121	50	570	550	100	(1)	500	20	100	42	300	80	(2)	665	4	597			

BGAM = Base and coupling
 * = Indicatives values according to the type of motor installed.
 (1) PMXT=25 bar PMXST=25 bar PMXHT=40 bar
 (2) PMXT=40 bar PMXST=63 bar PMXHT=100 bar

BGAMA = Рама и муфта
 * = Приблизит. значения в зависимости от марки двигателя.
 (1) PMXT=25 бар PMXST=25 бар PMXHT=40 бар
 (2) PMXT=40 бар PMXST=63 бар PMXHT=100 бар

BGAM = Base giunto e coprigiunto
 * = Valori indicativi in funzione della marca di motore utilizzato.
 (1) PMXT=25 bar PMXST=25 bar PMXHT=40 bar
 (2) PMXT=40 bar PMXST=63 bar PMXHT=100 bar

COUPLINGS WITH STANDARDIZED ENCLOSED ELECTRIC MOTORS
 СОЕДИНЕНИЕ С НОРМАЛИЗОВАННЫМИ ЗАКРЫТЫМИ ЭЛЕКТРОДВИГАТЕЛЯМИ
 ACCORPIAMENTI CON MOTORI ELETTRICI CHIUSI NORMALIZZATI

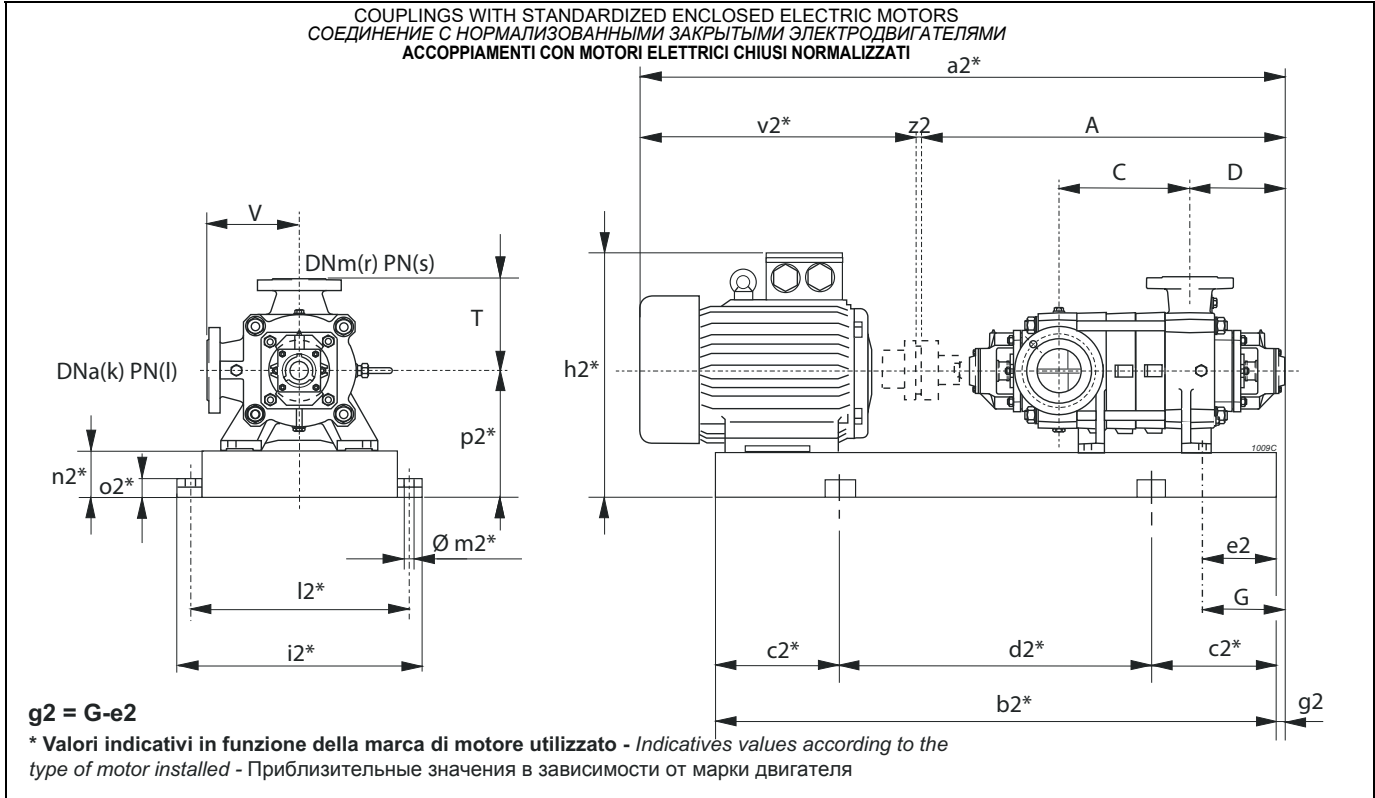

Pump Насос Pompa	Motor Двигатель Motore	BGAM	A	C	D	G	T	V	a2*	b2*	c2*	d2*	e2	h2*	i2*	k	l	l2*	m2*	n2*	o2*	p2*	r	s	v2*	z2	Weight Вес Peso		
Series Серия Serie	Type Тип Tipo	[kW]	Size Размер Grand.	Type Тип Tipo	[mm]																							[kg]	
PMX(S/H)T	/10	22	180L	686/FN	1364,5	730,5	274	245	245	245	2073,5	1759	300	1159	50	570	550	100	(1)	500	20	100	42	300	80	(2)	758	4	618
PMX(S/H)T	/10	30	200L	687/GN	1364,5	730,5	274	245	245	245	2126,5	1794	300	1194	50	600	550	100	(1)	500	20	100	42	300	80	(2)	758	4	680
PMX(S/H)T	80/11	15	160L	688/EN	1434,5	800,5	274	245	245	245	2065,5	1781	300	1181	50	551	550	100	(1)	500	20	100	42	300	80	(2)	627	4	582
PMX(S/H)T	/11	18,5	180M	689/FN	1434,5	800,5	274	245	245	245	2103,5	1791	300	1191	50	570	550	100	(1)	500	20	100	42	300	80	(2)	665	4	620
PMX(S/H)T	/11	22	180L	690/FN	1434,5	800,5	274	245	245	245	2143,5	1829	300	1229	50	570	550	100	(1)	500	20	100	42	300	80	(2)	705	4	640
PMX(S/H)T	/11	30	200L	691/GN	1434,5	800,5	274	245	245	245	2196,5	1864	300	1264	50	600	550	100	(1)	500	20	100	42	300	80	(2)	758	4	702
PMX(S/H)T	80/12	15	160L	692/EN	1504,5	870,5	274	245	245	245	2135,5	1851	300	1251	50	551	550	100	(1)	500	20	100	42	300	80	(2)	627	4	605
PMX(S/H)T	/12	18,5	180M	693/FN	1504,5	870,5	274	245	245	245	2173,5	1861	300	1261	50	570	550	100	(1)	500	20	100	42	300	80	(2)	665	4	656
PMX(S/H)T	/12	22	180L	694/FN	1504,5	870,5	274	245	245	245	2213,5	1899	300	1299	50	570	550	100	(1)	500	20	100	42	300	80	(2)	705	4	663
PMX(S/H)T	/12	30	200L	695/GN	1504,5	870,5	274	245	245	245	2266,5	1934	300	1334	50	600	550	100	(1)	500	20	100	42	300	80	(2)	758	4	725
PMX(S/H)T	80/13	15	160L	1230/GN	1574,5	940,5	274	245	245	245	2205,5	1921	300	1321	50	551	550	100	(1)	500	20	100	42	300	80	(2)	627	4	630
PMX(S/H)T	/13	18,5	180M	1231/FN	1574,5	940,5	274	245	245	245	2243,5	1931	300	1331	50	570	550	100	(1)	500	20	100	42	300	80	(2)	665	4	665
PMX(S/H)T	/13	22	180L	1232/FN	1574,5	940,5	274	245	245	245	2283,5	1969	350	1269	50	570	550	100	(1)	500	20	100	42	300	80	(2)	705	4	685
PMX(S/H)T	/13	30	200L	1233/FN	1574,5	940,5	274	245	245	245	2336,5	2004	350	1304	50	600	550	100	(1)	500	20	100	42	300	80	(2)	758	4	747
PMX(S/H)T	80/14	15	160L	1234/EN	1644,5	1010,5	274	245	245	245	2275,5	1991	350	1291	50	551	550	100	(1)	500	20	100	42	300	80	(2)	627	4	650
PMX(S/H)T	/14	18,5	180M	1235/FN	1644,5	1010,5	274	245	245	245	2313,5	2001	350	1301	50	570	550	100	(1)	500	20	100	42	300	80	(2)	665	4	687
PMX(S/H)T	/14	22	180L	1236/FN	1644,5	1010,5	274	245	245	245	2353,5	2039	350	1339	50	570	550	100	(1)	500	20	100	42	300	80	(2)	705	4	708
PMX(S/H)T	/14	30	200L	1237/GN	1644,5	1010,5	274	245	245	245	2406,5	2074	350	1374	50	600	550	100	(1)	500	20	100	42	300	80	(2)	758	4	770
PMX(S/H)T	/14	37	225S	1238/HQ	1644,5	1010,5	274	245	245	245	2441,5	2125	350	1425	70	675	585	100	(1)	535	20	120	42	345	80	(2)	793	4	840
PMX(S/H)T	80/15	15	160L	2234/EN	1714,5	1080,5	274	245	245	245	2345,5	2061	350	1361	50	551	550	100	(1)	500	20	100	42	300	80	(2)	627	4	672
PMX(S/H)T	/15	18,5	180M	1239/FN	1714,5	1080,5	274	245	245	245	2383,5	2071	350	1371	50	570	550	100	(1)	500	20	100	42	300	80	(2)	665	4	710
PMX(S/H)T	/15	22	180L	1240/FN	1714,5	1080,5	274	245	245	245	2423,5	2109	350	1409	50	570	550	100	(1)	500	20	100	42	300	80	(2)	705	4	730
PMX(S/H)T	/15	30	200L	1241/GN	1714,5	1080,5	274	245	245	245	2476,5	2144	350	1444	50	600	550	100	(1)	500	20	100	42	300	80	(2)	758	4	792
PMX(S/H)T	/15	37	225S	1242/HQ	1714,5	1080,5	274	245	245	245	2511,5	2195	350	1495	70	675	585	100	(1)	535	20	120	42	345	80	(2)	793	4	863
PMX(S/H)T	80/16	18,5	180M	1243/FN	1784,5	1150,5	274	245	245	245	2453,5	2141	350	1441	50	570	550	100	(1)	500	20	100	42	300	80	(2)	665	4	732
PMX(S/H)T	/16	22	180L	1244/FN	1784,5	1150,5	274	245	245	245	2493,5	2179	350	1479	50	570	550	100	(1)	500	20	100	42	300	80	(2)	705	4	753
PMX(S/H)T	/16	30	200L	1245/GN	1784,5	1150,5	274	245	245	245	2546,5	2214	350	1514	50	600	550	100	(1)	500	20	100	42	300	80	(2)	758	4	815
PMX(S/H)T	/16	37	225S	1246/HQ	1784,5	1150,5	274	245	245	245	2581,5	2265	400	1465	70	675	585	100	(1)	535	20	120	42	345	80	(2)	793	4	885

BGAM = Base and coupling
 * = Indicatives values according to the type of motor installed.
 (1) PMXT=25 bar PMXST=25 bar PMXHT=40 bar
 (2) PMXT=40 bar PMXST=63 bar PMXHT=100 bar

BGAMA = Рама и муфта
 * = Приблизит. значения в зависимости от марки двигателя.
 (1) PMXT=25 бар PMXST=25 бар PMXHT=40 бар
 (2) PMXT=40 бар PMXST=63 бар PMXHT=100 бар

BGAM = Base giunto e coprigiunto
 * = Valori indicativi in funzione della marca di motore utilizzato.
 (1) PMXT=25 bar PMXST=25 bar PMXHT=40 bar
 (2) PMXT=40 bar PMXST=63 bar PMXHT=100 bar

Utilization field Область применения Campo di utilizzo ≥ 60% η		
Stage number: compatibly with the maximum pressure. Кол-во ступеней: совместимое с макс. давлением. Numero stadi: compatibilmente con la pressione massima di esercizio.		
Type Тип Tipo	MIN.	MAX.
PMXT	2	11
PMXST	2	11
PMXHT	4	11
NB. For two-stage pumps only, reduce efficiency by one point. Только для двухступенчатых насосов - снизить КПД на 1 единицу Solamente per le pompe a due stadi, ridurre di un punto il rendimento.		

Wet moment of inertia J Момент инерции J мокрый Momento d'inerzia J bagnato $J = \frac{1}{2} PD^2$ - [kg m ²]		
Impeller type Тип раб. колеса Girante tipo	PMX(S/H)T100/1	For each additional stage Для каждой доп. ступени Per ogni stadio in più
Stainless steel Нержав. сталь Acciaio inox	0,0344	0,0306

Maximum permissible power Макс. допустимая мощность Massime potenze ammissibili	
Type Тип Tipo	N/n MAX.
PMXT	0,13
PMXST	0,13
PMXHT	0,13
For seal limits and calculation formulas of the maximum permissible powers, see technical data section. Ограничения по уплотнениям и формулы расчета макс. допустимой мощности - см. раздел "Технические данные". Per i limiti tenute e le formule di calcolo delle massime potenze ammissibili, vedere sezione dati tecnici.	

PERFORMANCES EACH INTERMEDIATE STAGE
ХАРАКТЕРИСТИКИ ОДНОЙ СТУПЕНИ
PRESTAZIONI PER STADIO

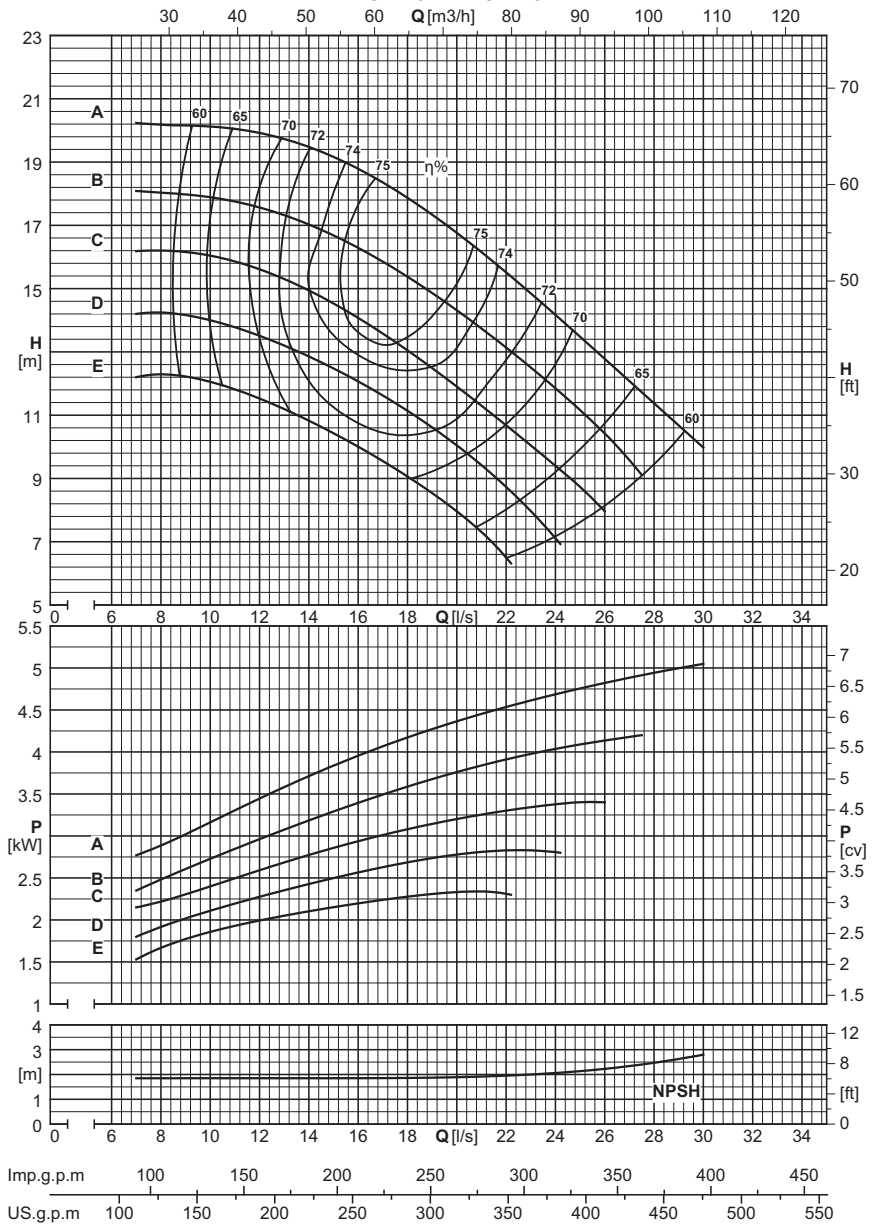

Capacity - Расход - Portata																													
Dna x DNm	Impeller type Тип раб. кол. Girante tipo	[l/s]	0	10	11	12	13	14	15	16	17	18	19	20	21	22	23	24	25	26	27	28							
		[m³/h]	0	36	39,6	43,2	46,8	50,4	54	57,6	61,2	64,8	68,4	72	75,6	79,2	82,8	86,4	90	93,6	97,2	100,8							
		[l/min]	0	600	660	720	780	840	900	960	1020	1080	1140	1200	1260	1320	1380	1440	1500	1560	1620	1680							

		PMX(S/H)T100/1																											
125x100	E	[m]	12	12,5	12	11,5	11	11	10,5	10	9,5	9,1	8,5	8	7,4														
125x100	E	[kW]		1,8	1,9	2	2,1	2,1	2,2	2,2	2,3	2,3	2,3	2,4	2,4														
125x100	D	[m]	13,5	13,5	13,5	14	13,5	13,5	12,5	12	11,5	11	10,5	10	9,5	8,6	7,8												
125x100	D	[kW]		2,1	2,2	2,2	2,3	2,4	2,5	2,6	2,6	2,7	2,8	2,8	2,9	2,8	2,8												
125x100	C	[m]	15,5	16,5	16	15,5	15,5	15	14,5	14	13,5	13,5	12,5	12	11,5	10,5	10	9,4	8,7										
125x100	C	[kW]		2,4	2,5	2,6	2,7	2,8	2,9	2,9	3	3,1	3,1	3,2	3,3	3,3	3,3	3,4	3,4										
125x100	B	[m]	19	18,5	18	19	18	16,5	16,5	16	15,5	15,5	15	14,5	13,5	13	12,5	12	11	10									
125x100	B	[kW]		2,7	2,8	2,8	2,9	3	3,2	3,3	3,4	3,5	3,6	3,7	3,8	3,8	3,9	4	4	4,1	4,1								
125x100	A	[m]	20,5		19,5	19,5	20	20	19,5	18,5	18	18	17,5	17	16	15,5	15	14	13,5	12,5	12	11,5							
125x100	A	[kW]			3,4	3,5	3,6	3,7	3,8	4	4,1	4,2	4,3	4,3	4,4	4,6	4,6	4,7	4,7	4,8	4,8	5							
		NPSH																											
		[m]		1,8	1,8	1,8	1,8	1,8	1,9	1,9	1,9	1,9	1,9	1,9	1,9	1,9	2	2	2,1	2,1	2,2	2,4	2,4						

Utilization field Область применения Campo di utilizzo ≥ 60% η		
Stage number: compatibly with the maximum pressure. Кол-во ступеней: совместимое с макс. давлением. Numero stadi: compatibilmente con la pressione massima di esercizio.		
Type Тип Tipo	MIN.	MAX.
PMXT	2	11
PMXST	2	11
PMXHT	4	11
NB. For two-stage pumps only, reduce efficiency by one point. Только для двухступенчатых насосов - снизить КПД на 1 единицу Solamente per le pompe a due stadi, ridurre di un punto il rendimento.		

Wet moment of inertia J Момент инерции J мокрый Momento d'inerzia J bagnato J=¼PD ² - [kg m ²]		
Impeller type Тип раб. колеса Girante tipo	PMX(S/H)T100/1	For each additional stage Для каждой доп. ступени Per ogni stadio in più
Stainless steel Нержав. сталь Acciaio inox	0,0344	0,0306

Maximum permissible power Макс. допустимая мощность Massime potenze ammissibili	
Type Тип Tipo	N/h MAX.
PMXT	0,13
PMXST	0,13
PMXHT	0,13
For seal limits and calculation formulas of the maximum permissible powers, see technical data section. Ограничения по уплотнениям и формулы расчета макс. допустимой мощности - см. раздел "Технические данные". Per i limiti tenute e le formule di calcolo delle massime potenze ammissibili, vedere sezione dati tecnici.	

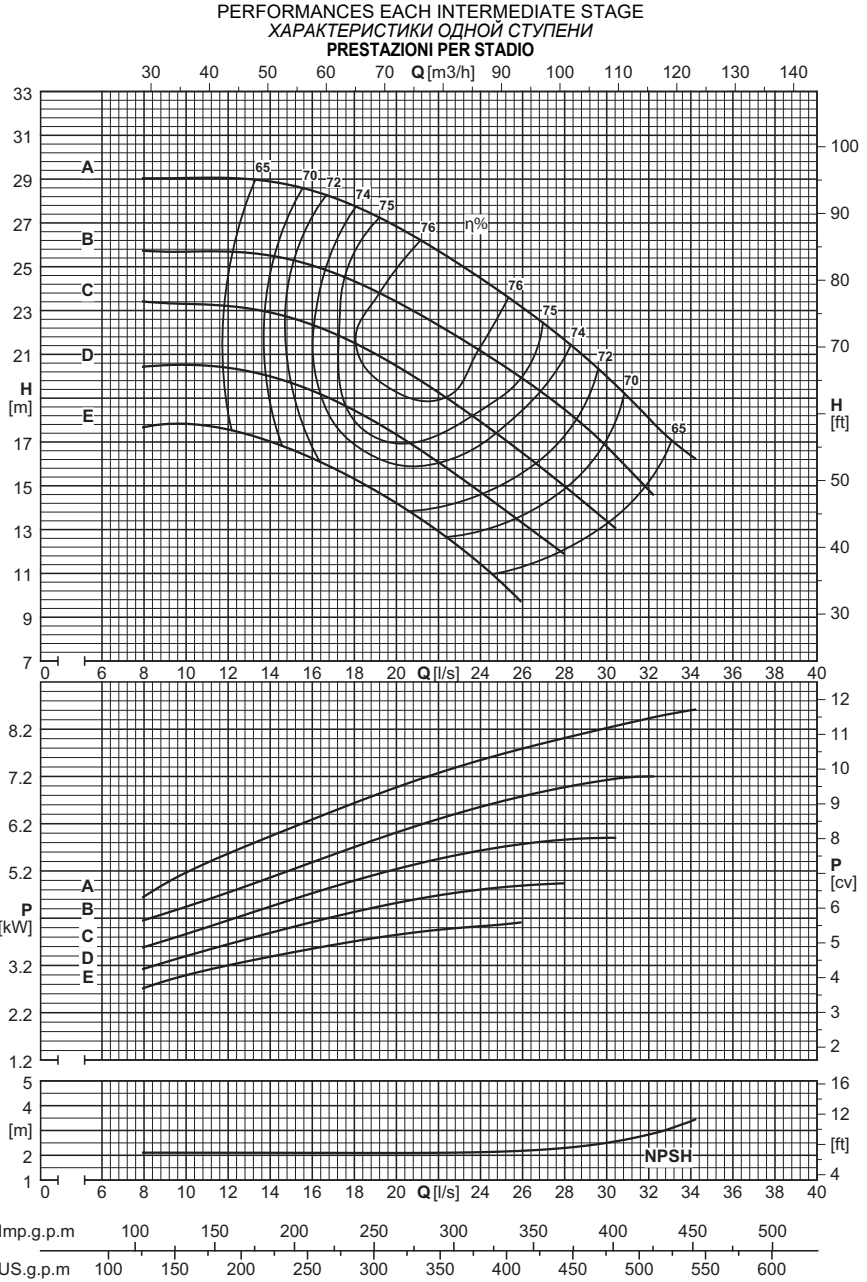

Dna x Dnm	Impeller type Тип раб. кол. Girante tipo	Capacity - Расход - Portata																											
		[l/s]	0	14	15	16	17	18	19	20	21	22	23	24	25	26	27	28	29	30	31	32	33	34					
		[m ³ /h]	0	50,4	54	57,6	61,2	64,8	68,4	72	75,6	79,2	82,8	86,4	90	93,6	97,2	100,8	104,4	108	111,6	115,2	118,8	122,4					
		[l/min]	0	840	900	960	1020	1080	1140	1200	1260	1320	1380	1440	1500	1560	1620	1680	1740	1800	1860	1920	1980	2040					

		PMX(S/H)T100/1																																		
125x100	E	[m]	17,5	16,5	16,5	16,5	16,5	15,5	15	14	13,5	13	12	11,5	10,5																					
125x100	E	[kW]		3,4	3,5	3,5	3,6	3,7	3,7	3,8	3,9	3,9	4	4	4,1																					
125x100	D	[m]	19,5	20,5	20	19,5	19	18,5	17,5	17	16,5	16,5	15,5	14,5	14,5	13,5	12,5	12																		
125x100	D	[kW]		3,8	4	4,1	4,2	4,3	4,5	4,6	4,7	4,7	4,8	4,8	4,9	4,9	4,9	4,9																		
125x100	C	[m]	23	22,5	22,5	22,5	22,5	22	21	20,5	20	19,5	18,5	18	17	16,5	16	15,5	14	13,5	13															
125x100	C	[kW]		4,5	4,6	4,7	4,8	4,9	5,2	5,3	5,4	5,5	5,6	5,8	5,8	5,8	5,9	5,8	5,8	6																
125x100	B	[m]	26,5	26	26	24,5	24,5	24,5	24	23,5	22,5	22,5	22	21,5	20,5	20	19	18,5	18	17	16	14,5	14													
125x100	B	[kW]		5	5,1	5,5	5,6	5,7	5,8	6,1	6,2	6,3	6,4	6,5	6,7	6,8	6,9	7,2	7,2	7,2	7,2	7,4														
125x100	A	[m]	29,5	28	28,5	29	30	27,5	27,5	27	26	25,5	25	24,5	23,5	23	22,5	21,5	21	20	19	18,5	17	16,5												
125x100	A	[kW]		6,1	6,1	6,2	6,3	6,7	6,8	6,9	7,2	7,3	7,4	7,4	7,8	7,8	7,9	7,9	8,2	8,2	8,3	8,5	8,6	8,6												
		NPSH																																		
		[m]		2,1	2,1	2,1	2,1	2,1	2,1	2,1	2,1	2,1	2,1	2,1	2,2	2,2	2,2	2,3	2,4	2,5	2,6	2,9	3	3,4												

Utilization field Область применения Campo di utilizzo ≥ 60% η		
Stage number: compatibly with the maximum pressure. Кол-во ступеней: совместимое с макс. давлением. Numero stadi: compatibilmente con la pressione massima di esercizio.		
Type Тип Tipo	MIN.	MAX.
PMXT	2	11
PMXST	2	11
PMXHT	4	11
NB. For two-stage pumps only, reduce efficiency by one point. Только для двухступенчатых насосов - снизить КПД на 1 единицу Solamente per le pompe a due stadi, ridurre di un punto il rendimento.		

Wet moment of inertia J Момент инерции J мокрый Momento d'inerzia J bagnato J=¼PD ² - [kg m ²]		
Impeller type Тип раб. колеса Girante tipo	PMX(S/H)T100/1	For each additional stage Для каждой доп. ступени Per ogni stadio in più
Stainless steel Нержав. сталь Acciaio inox	0,0344	0,0306

Maximum permissible power Макс. допустимая мощность Massime potenze ammissibili	
Type Тип Tipo	N/h MAX.
PMXT	0,13
PMXST	0,13
PMXHT	0,13
For seal limits and calculation formulas of the maximum permissible powers, see technical data section. Ограничения по уплотнениям и формулы расчета макс. допустимой мощности - см. раздел "Технические данные". Per i limiti tenute e le formule di calcolo delle massime potenze ammissibili, vedere sezione dati tecnici.	

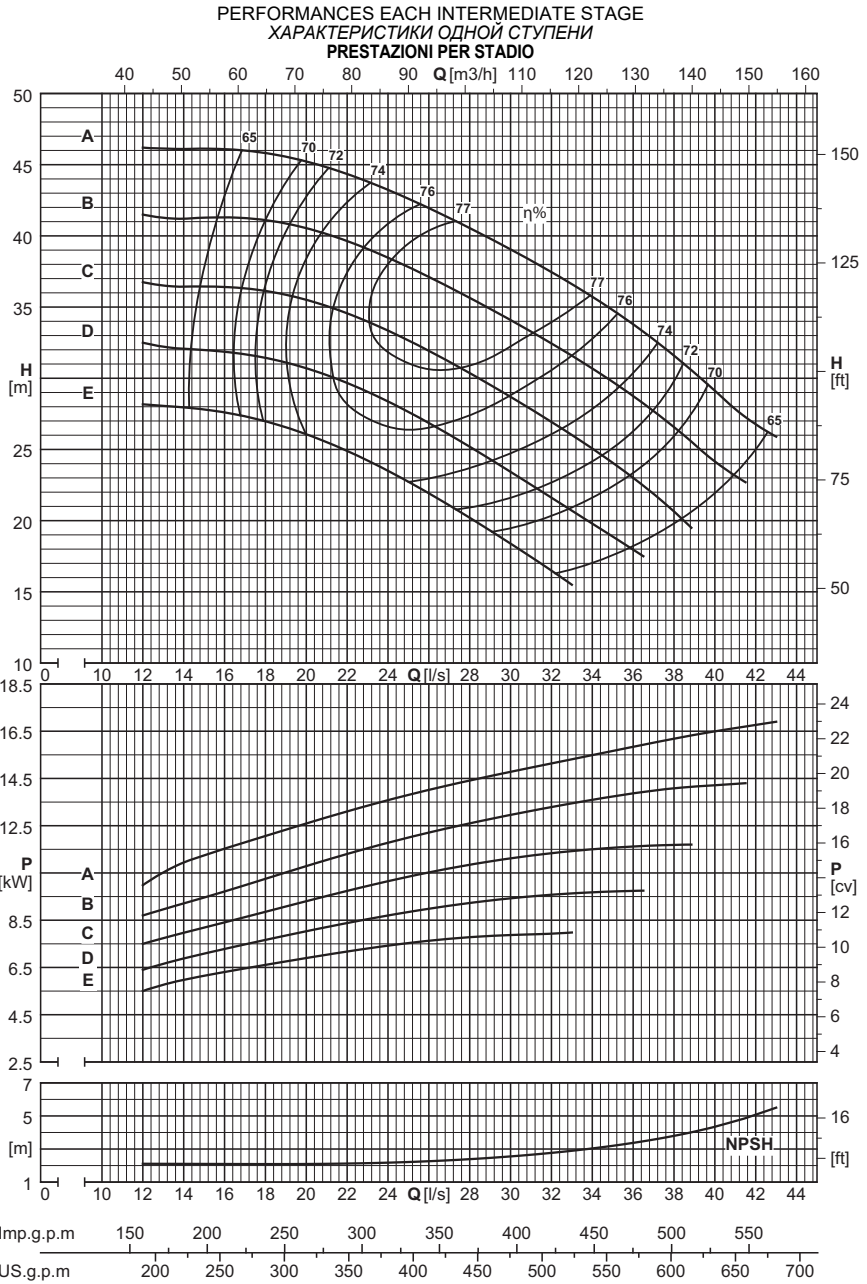

Dna x Dnm	Impeller type Тип раб. кол. Girante tipo	Capacity - Расход - Portata																	
		[l/s]	0	14	16	18	20	22	24	26	28	30	32	34	36	38	40	42	44
		[m³/h]	0	50,4	57,6	64,8	72	79,2	86,4	93,6	100,8	108	115,2	122,4	129,6	136,8	144	151,2	158,4
		[l/min]	0	840	960	1080	1200	1320	1440	1560	1680	1800	1920	2040	2160	2280	2400	2520	2640

		PMX(S/H)T100/1																	
125x100	E	[m]	27,5	28,5	28	26,5	26	25	23,5	22	20,5	18,5	16,5	15,5					
125x100	E	[kW]		5,9	6,2	6,7	7	7,2	7,4	7,6	7,9	7,9	8	8,2					
125x100	D	[m]	31	33,5	31,5	32	30,5	30	28	27	25	23,5	21,5	20	17,5	17			
125x100	D	[kW]		6,7	7,3	7,6	8,1	8,3	8,8	8,9	9,3	9,4	9,4	9,7	9,6	10,2			
125x100	C	[m]	36		37	35,5	36	34,5	33	32	30	28,5	27	25	23,5	21	19		
125x100	C	[kW]			8,3	8,9	9,2	9,8	10,3	10,5	11	11	11,4	11,3	11,6	11,8	12		
125x100	B	[m]	42,5		43,5	41,5	40	38,5	39	37	35,5	34,5	32,5	30,5	29	26,5	24	22,5	
125x100	B	[kW]			9,5	10,2	10,9	11,5	11,7	12,2	12,7	12,8	13,2	13,7	14,1	14	14,2	14,5	
125x100	A	[m]	46			47,5	45,5	44,5	42,5	42,5	41	40	37,5	35,5	33,5	31,5	29,5	27,5	25,5
125x100	A	[kW]				11,9	12,5	13,2	13,8	13,8	14,3	14,8	15,5	15,5	15,5	16	16,5	17	17,5
		NPSH																	
		[m]		2,1	2,1	2,1	2,1	2,1	2,2	2,3	2,4	2,6	2,8	3	3,4	3,8	4,3	4,9	5,6

Utilization field Область применения Campo di utilizzo ≥ 60% η		
Stage number: compatibly with the maximum pressure. Кол-во ступеней: совместимое с макс. давлением. Numero stadi: compatibilmente con la pressione massima di esercizio.		
Type Тип Tipo	MIN.	MAX.
PMXT	2	8
PMXST	2	8
PMXHT	4	11
NB. For two-stage pumps only, reduce efficiency by one point. Только для двухступенчатых насосов - снизить КПД на 1 единицу Solamente per le pompe a due stadi, ridurre di un punto il rendimento.		

Wet moment of inertia J Момент инерции J мокрый Momento d'inerzia J bagnato J=¼PD ² - [kg m ²]		
Impeller type Тип раб. колеса Girante tipo	PMX(S/H)T100/1	For each additional stage Для каждой доп. ступени Per ogni stadio in più
Stainless steel Нержав. сталь Acciaio inox	0,0344	0,0306

Maximum permissible power Макс. допустимая мощность Massime potenze ammissibili	
Type Тип Tipo	N/n MAX.
PMXT	0,13
PMXST	0,13
PMXHT	0,13
For seal limits and calculation formulas of the maximum permissible powers, see technical data section. Ограничения по уплотнениям и формулы расчета макс. допустимой мощности - см. раздел "Технические данные". Per i limiti tenute e le formule di calcolo delle massime potenze ammissibili, vedere sezione dati tecnici.	

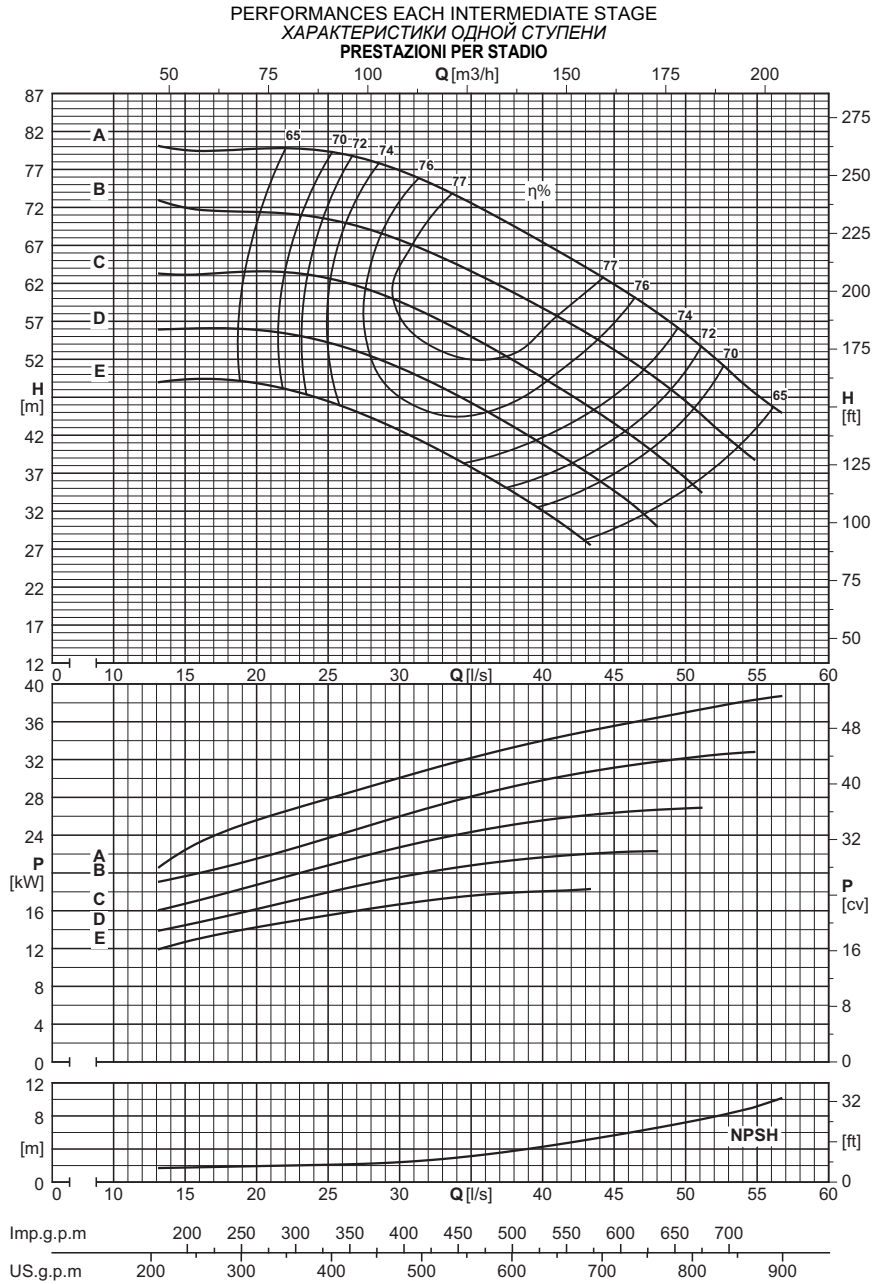

Capacity - Расход - Portata																							
Dna x DNm	Impeller type Тип раб. кол. / Girante tipo	[l/s]	0	20	22	24	26	28	30	32	34	36	38	40	42	44	46	48	50	52	54	56	
		[m ³ /h]	0	72	79,2	86,4	93,6	100,8	108	115,2	122,4	129,6	136,8	144	151,2	158,4	165,6	172,8	180	187,2	194,4	201,6	
		[l/min]	0	1200	1320	1440	1560	1680	1800	1920	2040	2160	2280	2400	2520	2640	2760	2880	3000	3120	3240	3360	
PMX(S/H)T100/1																							
125x100	E	[m]	47,5	48	49,5	47,5	45,5	44	43,5	41	39	36,5	34,5	32	29,5	27							
125x100	E	[kW]		14,5	14,5	15	16	16,5	16,5	17,5	17,5	19	17,5	19	18,5	18,5							
125x100	D	[m]	54	57	56	55	53	52	50	49	47,5	45,5	43	40,5	38,5	36	33	30					
125x100	D	[kW]		16	17	17,5	18,5	20	19,5	20,5	21	21,5	21	21,5	21,5	22	22	22,5					
125x100	C	[m]	62	60	61	61	60	59	58	57	55	53	51	49,5	47,5	45,5	42,5	40	37	34			
125x100	C	[kW]		19	20	21	21,5	22,5	23	24	24,5	25,5	25,5	26	26,5	26,5	27	27	27,5	27,5			
125x100	B	[m]	73	70	71	71	70	70	68	67	65	61	60	58	56	54	52	49,5	46	42,5	39,5	39	
125x100	B	[kW]		21,5	22,5	23	24,5	25	25,5	26,5	27	29	29,5	30	30,5	31	31,5	31,5	32	32	32,5	33,5	
125x100	A	[m]	79		81	81	81	75	75	74	73	71	69	67	65	62	60	58	55	52	48,5	45,5	
125x100	A	[kW]			26,5	27,5	27,5	30	30,5	31	32	32,5	33	33,5	34	36	36	36,5	37	37,5	38	38	
NPSH																							
		[m]		1,9	2	2,1	2,1	2,2	2,4	2,7	2,9	3,3	3,8	4,3	4,8	5,3	6	6,6	7,2	7,9	8,8	10	

Overall dimensions and weights
 Общие забарумы и вес
 Dimensioni di ingombro e pesi

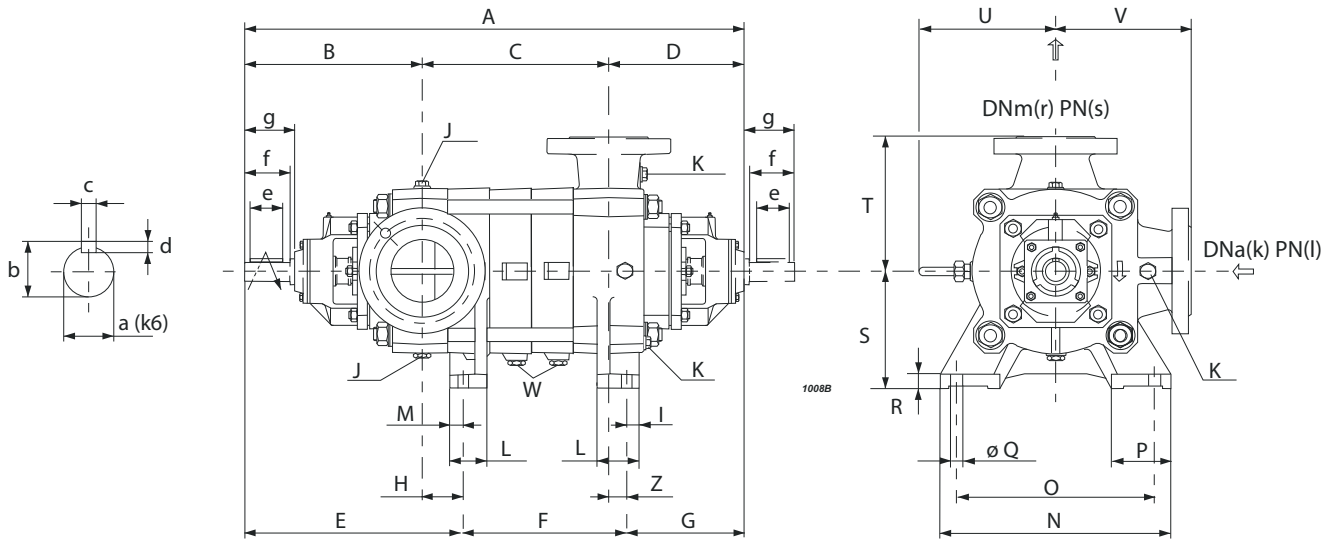

Series Серия Serie	Type Тип Tipo	A	B	C	D	E	F	G	H	S	T	U	V	Z	Weight Вес Peso
		[mm]													[kg]
PMX(S)T	100/2	828	365	170	293	419	149	260	53,5	225	270	273	270	33	239
PMX(S)T	100/3	903	365	245	293	419	224	260	53,5	225	270	273	270	33	266
PMX(S/H)T	100/4	978	365	320	293	419	299	260	53,5	225	270	273	270	33	295
PMX(S/H)T	100/5	1053	365	395	293	419	374	260	53,5	225	270	273	270	33	322
PMX(S/H)T	100/6	1128	365	470	293	419	449	260	53,5	225	270	273	270	33	349
PMX(S/H)T	100/7	1203	365	545	293	419	524	260	53,5	225	270	273	270	33	376
PMX(S/H)T	100/8	1278	365	620	293	419	599	260	53,5	225	270	273	270	33	404
PMX(S/H)T	100/9	1353	365	695	293	419	674	260	53,5	225	270	273	270	33	431
PMX(S/H)T	100/10	1428	365	770	293	419	749	260	53,5	225	270	273	270	33	458
PMX(S/H)T	100/11	1503	365	845	293	419	824	260	53,5	225	270	273	270	33	486

Foot dimensions Размеры ножек Dimensioni dei piedi							
I	L	M	N	O	P	Q	R
[mm]							
32	85	32	460	400	117	24	30

Shaft projection Выступ вала Sporgenza d'albero							
a	b	c	d	e	f	g	
[mm]							
35	38	10	8	70	90	104	

Flanges Фланцы Flange				
Type Тип Tipo	(k)	(l)	(r)	(s)
	DNa	PN	DNm	PN
	[mm]	[bar]	[mm]	[bar]
PMXT	125	25	100	40
PMXST	125	25	100	63
PMXHT	125	40	100	100

Plugs Пробки Tappi		
J	K	W
G1/2	G1/2	G1/4

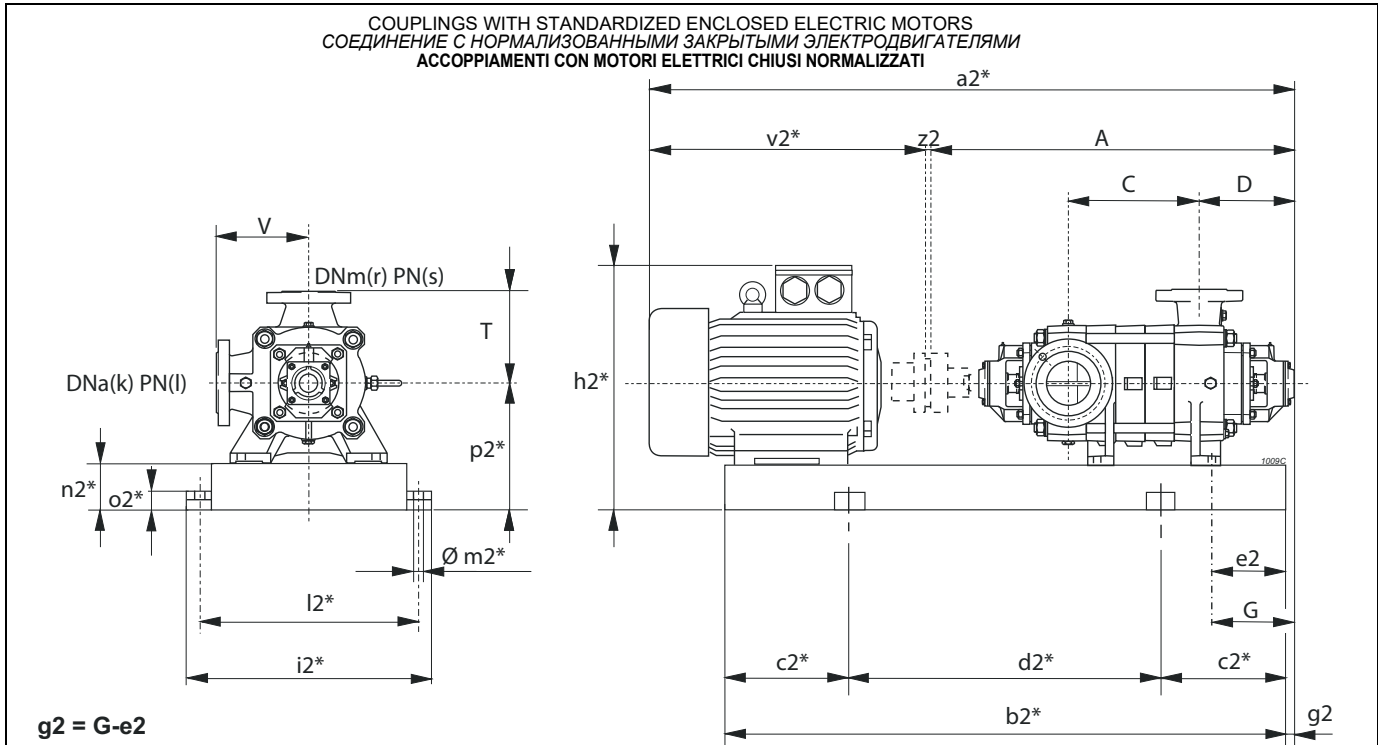

$g2 = G - e2$

* Valori indicativi in funzione della marca di motore utilizzato - Indicatives values according to the type of motor installed - Приблизительные значения в зависимости от марки двигателя

Pump Насос Помпа		Motor Двигатель Motore		BGAM	A	C	D	G	T	V	a2*	b2*	c2*	d2*	e2	h2*	i2*	k	l	l2*	m2*	n2*	o2*	p2*	r	s	v2*	z2	Weight Вес Peso				
Series Серия Serie	Type Тип Tipo	[kW]	Size Размер Grand.	Type Тип Tipo	[mm]																												[kg]
PMX(S)T	100/2	45	225M	775/FN	827,5	169,5	293	260	270	270	1606,5	1268	200	868	50	675	590	125	(1)	540	20	120	42	345	100	(2)	775	4	609				
PMX(S)T	/2	55	250M	776/GQ	827,5	169,5	293	260	270	270	1701,5	1360	250	860	70	745	635	125	(1)	585	20	120	42	370	100	(2)	870	4	708				
PMX(S)T	/2	75	280S	777/HQ	827,5	169,5	293	260	270	270	1831,5	1407	250	907	70	815	695	125	(1)	645	20	140	42	420	100	(2)	1000	4	895				
PMX(S)T	/2	90	280M	778/HQ	827,5	169,5	293	260	270	270	1882,5	1458	250	958	70	815	695	125	(1)	645	20	140	42	420	100	(2)	1051	4	1023				
PMX(S)T	100/3	75	280S	779/HQ	902,5	244,5	293	260	270	270	1906,5	1482	250	982	70	815	695	125	(1)	645	20	140	42	420	100	(2)	1000	4	922				
PMX(S)T	/3	90	280M	780/HQ	902,5	244,5	293	260	270	270	1957,5	1533	250	1033	70	815	695	125	(1)	645	20	140	42	420	100	(2)	1051	4	1051				
PMX(S)T	/3	110	315S	781/IQ	902,5	244,5	293	260	270	270	2087,5	1609	250	1109	100	1030	780	125	(1)	730	22	160	50	475	100	(2)	1181	4	1409				
PMX(S)T	/3	132	315M	782/IQ	902,5	244,5	293	260	270	270	2197,5	1668	300	1068	100	1030	780	125	(1)	730	22	160	50	475	100	(2)	1291	4	1484				
PMX(S/H)T	100/4	90	280M	783/HQ	977,5	319,5	293	260	270	270	2032,5	1608	250	1108	70	815	695	125	(1)	645	20	140	42	420	100	(2)	1051	4	1079				
PMX(S/H)T	/4	110	315S	784/IQ	977,5	319,5	293	260	270	270	2162,5	1684	300	1084	100	1030	780	125	(1)	730	22	160	50	475	100	(2)	1181	4	1438				
PMX(S/H)T	/4	132	315M	785/IQ	977,5	319,5	293	260	270	270	2272,5	1743	300	1143	100	1030	780	125	(1)	730	22	160	50	475	100	(2)	1291	4	1512				
PMX(S/H)T	/4	160	315L	785/IQ	977,5	319,5	293	260	270	270	2272,5	1743	300	1143	100	1030	780	125	(1)	730	22	160	50	475	100	(2)	1291	4	1590				
PMX(S/H)T	/4	200	315L	786/IE4/LQ	977,5	319,5	293	260	270	270	2362,5	1884	300	1284	198	1030	780	125	(1)	730	22	160	50	475	100	(2)	1381	4	1709				
PMX(S/H)T	100/5	110	315S	787/IQ	1052,5	394,5	293	260	270	270	2237,5	1759	300	1159	100	1030	780	125	(1)	730	22	160	50	475	100	(2)	1181	4	1466				
PMX(S/H)T	/5	132	315M	788/IQ	1052,5	394,5	293	260	270	270	2347,5	1818	300	1218	100	1030	780	125	(1)	730	22	160	50	475	100	(2)	1291	4	1540				
PMX(S/H)T	/5	160	315L	788/IQ	1052,5	394,5	293	260	270	270	2347,5	1818	300	1218	100	1030	780	125	(1)	730	22	160	50	475	100	(2)	1291	4	1618				
PMX(S/H)T	/5	200	315L	789/IE4/LQ	1052,5	394,5	293	260	270	270	2437,5	1959	350	1259	198	1030	780	125	(1)	730	22	160	50	475	100	(2)	1381	4	1736				
PMX(S/H)T	/5	250	355M	790/LQ	1052,5	394,5	293	260	270	270	2582,5	1923	300	1323	100	1136	880	125	(1)	830	22	180	50	535	100	(2)	1526	4	2128				
PMX(S/H)T	100/6	132	315M	791/IQ	1127,5	469,5	293	260	270	270	2422,5	1893	300	1293	100	1030	780	125	(1)	730	22	160	50	475	100	(2)	1291	4	1568				
PMX(S/H)T	/6	160	315L	791/IQ	1127,5	469,5	293	260	270	270	2422,5	1893	300	1293	100	1030	780	125	(1)	730	22	160	50	475	100	(2)	1291	4	1646				
PMX(S/H)T	/6	200	315L	792/IE4/LQ	1127,5	469,5	293	260	270	270	2512,5	2034	350	1334	198	1030	780	125	(1)	730	22	160	50	475	100	(2)	1381	4	1764				
PMX(S/H)T	/6	250	355M	793/LQ	1127,5	469,5	293	260	270	270	2657,5	2068	350	1368	100	1136	880	125	(1)	830	22	180	50	535	100	(2)	1526	4	2160				
PMX(S/H)T	/6	280	355L	793/LQ	1127,5	469,5	293	260	270	270	2657,5	2068	350	1368	100	1136	880	125	(1)	830	22	180	50	535	100	(2)	1526	4	2285				
PMX(S/H)T	/6	315	355L	793/MQ	1127,5	469,5	293	260	270	270	2657,5	2068	350	1368	100	1136	880	125	(1)	830	22	180	50	535	100	(2)	1526	4	2289				
PMX(S/H)T	100/7	160	315L	798/IQ	1202,5	544,5	293	260	270	270	2497,5	2019	350	1319	100	1030	780	125	(1)	730	22	160	50	475	100	(2)	1291	4	1676				
PMX(S/H)T	/7	200	315L	794/IE4/LQ	1202,5	544,5	293	260	270	270	2587,5	2109	350	1409	198	1030	780	125	(1)	730	22	160	50	475	100	(2)	1381	4	1791				
PMX(S/H)T	/7	250	355M	795/LQ	1202,5	544,5	293	260	270	270	2732,5	2143	350	1443	100	1136	880	125	(1)	830	22	180	50	535	100	(2)	1526	4	2188				
PMX(S/H)T	/7	280	355L	795/LQ	1202,5	544,5	293	260	270	270	2732,5	2143	350	1443	100	1136	880	125	(1)	830	22	180	50	535	100	(2)	1526	4	2313				
PMX(S/H)T	/7	315	355L	795/MQ	1202,5	544,5	293	260	270	270	2732,5	2143	350	1443	100	1136	880	125	(1)	830	22	180	50	535	100	(2)	1526	4	2317				

BGAM = Base and coupling

* = Indicatives values according to the type of motor installed.

○ Motor in IE4 efficiency class according to EU REGULATION 2019/1781. Available in other efficiency classes for non-EU markets.

BGAMA = Рама и муфта

* = Приблизит. значения в зависимости от марки двигателя.

○ Двигатель класса эффективности IE4 в соответствии с РЕГЛАМЕНТОМ ЕС 2019/1781. Имеются варианты в других классах эффективности для рынков за пределами ЕС.

BGAM = Base giunto e coprighetto

* = Valori indicativi in funzione della marca di motore utilizzato.

○ Motore in classe di efficienza IE4 in conformità al REGOLAMENTO UE2019/1781. Disponibili in altre classi di efficienza per mercati extra UE.

- (1) PMXT=25 bar PMXST=25 bar PMXHT=40 bar
- (2) PMXT=40 bar PMXST=63 bar PMXHT=100 bar

- (1) PMXT=25 бар PMXST=25 бар PMXHT=40 бар
- (2) PMXT=40 бар PMXST=63 бар PMXHT=100 бар

- (1) PMXT=25 bar PMXST=25 bar PMXHT=40 bar
- (2) PMXT=40 bar PMXST=63 bar PMXHT=100 bar

COUPLINGS WITH STANDARDIZED ENCLOSED ELECTRIC MOTORS
 СОЕДИНЕНИЕ С НОРМАЛИЗОВАННЫМИ ЗАКРЫТЫМИ ЭЛЕКТРОДВИГАТЕЛЯМИ
 ACCOPPIAMENTI CON MOTORI ELETTRICI CHIUSI NORMALIZZATI

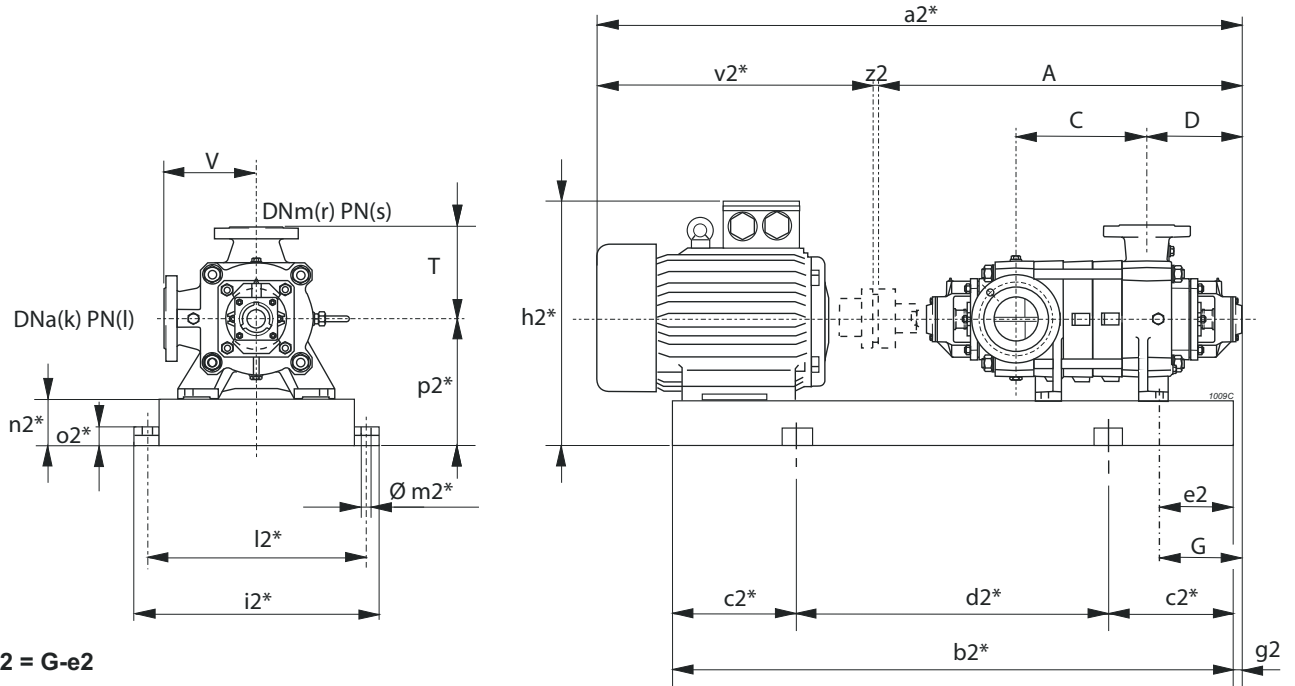

$g2 = G - e2$

* Valori indicativi in funzione della marca di motore utilizzato - Indicatives values according to the type of motor installed - Приблизительные значения в зависимости от марки двигателя

Pump Насос Помпа	Motor Двигатель Motore	BGAM	A	C	D	G	T	V	a2*	b2*	c2*	d2*	e2	h2*	i2*	k	l	l2*	m2*	n2*	o2*	p2*	r	s	v2*	z2	Weight Вес Peso		
Series Серия Serie	Type Тип Tipo	[kW]	Size Размер Grand.	Type Тип Tipo	[mm]																				[kg]				
PMX(S/H)T	100/8	160	315L	799/IQ	1277,5	619,5	293	260	270	270	2572,5	2094	350	1394	100	1030	780	125	(1)	730	22	160	50	475	100	(2)	1291	4	1704
PMX(S/H)T	/8	200	315L	796/IE4/LQ	1277,5	619,5	293	260	270	270	2662,5	2184	350	1484	198	1030	780	125	(1)	730	22	160	50	475	100	(2)	1381	4	1819
PMX(S/H)T	/8	250	355M	797/LQ	1277,5	619,5	293	260	270	270	2807,5	2218	350	1518	100	1136	880	125	(1)	830	22	180	50	535	100	(2)	1526	4	2216
PMX(S/H)T	/8	280	355L	797/LQ	1277,5	619,5	293	260	270	270	2807,5	2218	350	1518	100	1136	880	125	(1)	830	22	180	50	535	100	(2)	1526	4	2341
PMX(S/H)T	/8	315	355L	797/MQ	1277,5	619,5	293	260	270	270	2807,5	2218	350	1518	100	1136	880	125	(1)	830	22	180	50	535	100	(2)	1526	4	2345
PMX(S/H)T	/8	355	355L	797/MQ	1277,5	619,5	293	260	270	270	2807,5	2218	350	1518	100	1136	880	125	(1)	830	22	180	50	535	100	(2)	1526	4	2335
PMX(H)T	100/9	200	315L	1255/IE4/LQ	1352,5	694,5	293	260	270	270	2737,5	2259	400	1459	198	1030	780	125	(1)	730	22	160	50	475	100	(2)	1381	4	1847
PMX(H)T	/9	250	355M	1256/LQ	1352,5	694,5	293	260	270	270	2882,5	2293	400	1493	100	1136	880	125	(1)	830	22	180	50	535	100	(2)	1526	4	2245
PMX(H)T	/9	280	355L	1256/LQ	1352,5	694,5	293	260	270	270	2882,5	2293	400	1493	100	1136	880	125	(1)	830	22	180	50	535	100	(2)	1526	4	2370
PMX(H)T	/9	315	355L	1256/MQ	1352,5	694,5	293	260	270	270	2882,5	2293	400	1493	100	1136	880	125	(1)	830	22	180	50	535	100	(2)	1526	4	2374
PMX(H)T	/9	355	355L	1256/MQ	1352,5	694,5	293	260	270	270	2882,5	2293	400	1493	100	1136	880	125	(1)	830	22	180	50	535	100	(2)	1526	4	2364
PMX(H)T	100/10	200	315L	1257/IE4/LQ	1427,5	769,5	293	260	270	270	2812,5	2334	400	1534	198	1030	780	125	(1)	730	22	160	50	475	100	(2)	1381	4	1875
PMX(H)T	/10	250	355M	1258/MQ	1427,5	769,5	293	260	270	270	2957,5	2368	400	1568	100	1136	880	125	(1)	830	22	180	50	535	100	(2)	1526	4	2277
PMX(H)T	/10	280	355L	1258/MQ	1427,5	769,5	293	260	270	270	2957,5	2368	400	1568	100	1136	880	125	(1)	830	22	180	50	535	100	(2)	1526	4	2402
PMX(H)T	/10	315	355L	1258/MQ	1427,5	769,5	293	260	270	270	2957,5	2368	400	1568	100	1136	880	125	(1)	830	22	180	50	535	100	(2)	1526	4	2402
PMX(H)T	/10	355	355L	1258/MQ	1427,5	769,5	293	260	270	270	2957,5	2368	400	1568	100	1136	880	125	(1)	830	22	180	50	535	100	(2)	1526	4	2392
PMX(H)T	100/11	250	355M	1259/LQ	1502,5	844,5	293	260	270	270	3032,5	2443	400	1643	100	1136	880	125	(1)	830	22	180	50	535	100	(2)	1526	4	2303
PMX(H)T	/11	280	355L	1259/LQ	1502,5	844,5	293	260	270	270	3032,5	2443	400	1643	100	1136	880	125	(1)	830	22	180	50	535	100	(2)	1526	4	2428
PMX(H)T	/11	315	355L	1259/MQ	1502,5	844,5	293	260	270	270	3032,5	2443	400	1643	100	1136	880	125	(1)	830	22	180	50	535	100	(2)	1526	4	2432
PMX(H)T	/11	355	355L	1259/MQ	1502,5	844,5	293	260	270	270	3032,5	2443	400	1643	100	1136	880	125	(1)	830	22	180	50	535	100	(2)	1526	4	2422

BGAM = Base and coupling

* = Indicatives values according to the type of motor installed.

o Motor in IE4 efficiency class according to EU REGULATION 2019/1781. Available in other efficiency classes for non-EU markets.

- (1) PMXT=25 bar PMXST=25 bar PMXHT=40 bar
- (2) PMXT=40 bar PMXST=63 bar PMXHT=100 bar

BGAMA = Рама и муфта

* = Приблизит. значения в зависимости от марки двигателя.

o Двигатель класса эффективности IE4 в соответствии с РЕГЛАМЕНТОМ ЕС 2019/1781. Имеются варианты в других классах эффективности для рынков за пределами ЕС.

- (1) PMXT=25 бар PMXST=25 бар PMXHT=40 бар
- (2) PMXT=40 бар PMXST=63 бар PMXHT=100 бар

BGAM = Base giunto e coprigiunto

* = Valori indicativi in funzione della marca di motore utilizzato.

o Motore in classe di efficienza IE4 in conformità al REGOLAMENTO UE2019/1781. Disponibili in altre classi di efficienza per mercati extra UE.

- (1) PMXT=25 bar PMXST=25 bar PMXHT=40 bar
- (2) PMXT=40 bar PMXST=63 bar PMXHT=100 bar

COUPLINGS WITH STANDARDIZED ENCLOSED ELECTRIC MOTORS
 СОЕДИНЕНИЕ С НОРМАЛИЗОВАННЫМИ ЗАКРЫТЫМИ ЭЛЕКТРОДВИГАТЕЛЯМИ
 ACCOPIAMENTI CON MOTORI ELETTRICI CHIUSI NORMALIZZATI

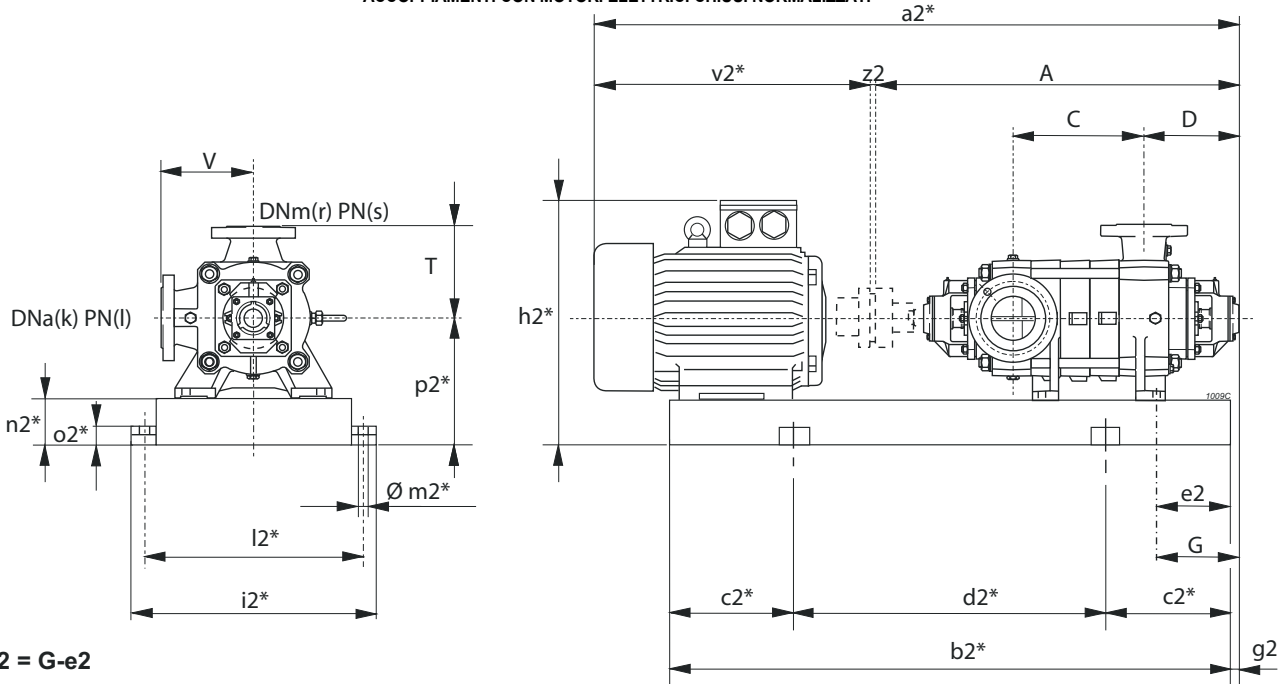

$g2 = G - e2$

* Valori indicativi in funzione della marca di motore utilizzato - Indicatives values according to the type of motor installed - Приблизительные значения в зависимости от марки двигателя

Pump Насос Pompa	Motor Двигатель Motore	BGAM	A	C	D	G	T	V	a2*	b2*	c2*	d2*	e2	h2*	i2*	k	l	l2*	m2*	n2*	o2*	p2*	r	s	v2*	z2	Weight Вес Peso	
Series Серия Serie	Type Тип Tipo	Size Размер Grand.	Type Тип Tipo	[mm]																						[kg]		
PMX(S)T	100/2	5,5	132S	730/CN	827,5	169,5	293	260	270	1286,5	971	150	671	50	537	590	125	(1)	540	20	120	42	345	100	(2)	455	4	324
PMX(S)T	/2	7,5	132M	731/DN	827,5	169,5	293	260	270	1321,5	1009	150	709	50	537	590	125	(1)	540	20	120	42	345	100	(2)	490	4	335
PMX(S)T	/2	11	160M	732/EN	827,5	169,5	293	260	270	1458,5	1115	200	715	50	596	590	125	(1)	540	20	120	42	345	100	(2)	627	4	433
PMX(S)T	100/3	7,5	132M	733/DN	902,5	244,5	293	260	270	1396,5	1084	200	684	50	537	590	125	(1)	540	20	120	42	345	100	(2)	490	4	362
PMX(S)T	/3	11	160M	734/EN	902,5	244,5	293	260	270	1533,5	1190	200	790	50	596	590	125	(1)	540	20	120	42	345	100	(2)	627	4	460
PMX(S)T	/3	15	160L	735/EN	902,5	244,5	293	260	270	1533,5	1234	200	834	50	596	590	125	(1)	540	20	120	42	345	100	(2)	627	4	473
PMX(S)T	/3	18,5	180M	736/FN	902,5	244,5	293	260	270	1571,5	1244	200	844	50	615	590	125	(1)	540	20	120	42	345	100	(2)	665	4	500
PMX(S/H)T	100/4	11	160M	737/EN	977,5	319,5	293	260	270	1608,5	1265	200	865	50	596	590	125	(1)	540	20	120	42	345	100	(2)	627	4	488
PMX(S/H)T	/4	15	160L	738/EN	977,5	319,5	293	260	270	1608,5	1309	200	909	50	596	590	125	(1)	540	20	120	42	345	100	(2)	627	4	501
PMX(S/H)T	/4	18,5	180M	739/FN	977,5	319,5	293	260	270	1646,5	1319	200	919	50	615	590	125	(1)	540	20	120	42	345	100	(2)	665	4	528
PMX(S/H)T	/4	22	180L	740/FN	977,5	319,5	293	260	270	1686,5	1357	250	857	50	615	590	125	(1)	540	20	120	42	345	100	(2)	705	4	549
PMX(S/H)T	100/5	15	160L	741/EN	1052,5	394,5	293	260	270	1683,5	1384	250	884	50	596	590	125	(1)	540	20	120	42	345	100	(2)	627	4	528
PMX(S/H)T	/5	18,5	180M	742/FN	1052,5	394,5	293	260	270	1721,5	1394	250	894	50	615	590	125	(1)	540	20	120	42	345	100	(2)	665	4	555
PMX(S/H)T	/5	22	180L	743/FN	1052,5	394,5	293	260	270	1761,5	1432	250	932	50	615	590	125	(1)	540	20	120	42	345	100	(2)	705	4	576
PMX(S/H)T	/5	30	200L	744/GN	1052,5	394,5	293	260	270	1814,5	1467	250	967	50	645	590	125	(1)	540	20	120	42	345	100	(2)	758	4	639
PMX(S/H)T	100/6	15	160L	745/EN	1127,5	469,5	293	260	270	1758,5	1459	250	959	50	596	590	125	(1)	540	20	120	42	345	100	(2)	627	4	555
PMX(S/H)T	/6	18,5	180M	746/FN	1127,5	469,5	293	260	270	1796,5	1469	250	969	50	615	590	125	(1)	540	20	120	42	345	100	(2)	665	4	582
PMX(S/H)T	/6	22	180L	747/FN	1127,5	469,5	293	260	270	1836,5	1507	250	1007	50	615	590	125	(1)	540	20	120	42	345	100	(2)	705	4	603
PMX(S/H)T	/6	30	200L	748/GN	1127,5	469,5	293	260	270	1889,5	1542	250	1042	50	645	590	125	(1)	540	20	120	42	345	100	(2)	758	4	666
PMX(S/H)T	/6	37	225S	749/HQ	1127,5	469,5	293	260	270	1924,5	1573	250	1073	50	675	590	125	(1)	540	20	120	42	345	100	(2)	793	4	711
PMX(S/H)T	100/7	18,5	180M	750/FN	1202,5	544,5	293	260	270	1871,5	1544	250	1044	50	615	590	125	(1)	540	20	120	42	345	100	(2)	665	4	609
PMX(S/H)T	/7	22	180L	751/FN	1202,5	544,5	293	260	270	1911,5	1582	250	1082	50	615	590	125	(1)	540	20	120	42	345	100	(2)	705	4	630
PMX(S/H)T	/7	30	200L	752/GN	1202,5	544,5	293	260	270	1964,5	1617	250	1117	50	645	590	125	(1)	540	20	120	42	345	100	(2)	758	4	693
PMX(S/H)T	/7	37	225S	753/HQ	1202,5	544,5	293	260	270	1999,5	1648	250	1148	50	675	590	125	(1)	540	20	120	42	345	100	(2)	793	4	738
PMX(S/H)T	100/8	22	180L	754/FN	1277,5	619,5	293	260	270	1986,5	1657	300	1057	50	615	590	125	(1)	540	20	120	42	345	100	(2)	705	4	657
PMX(S/H)T	/8	30	200L	755/GN	1277,5	619,5	293	260	270	2039,5	1692	300	1092	50	645	590	125	(1)	540	20	120	42	345	100	(2)	758	4	720
PMX(S/H)T	/8	37	225S	756/HQ	1277,5	619,5	293	260	270	2074,5	1723	300	1123	50	675	590	125	(1)	540	20	120	42	345	100	(2)	793	4	765
PMX(S/H)T	/8	45	225M	757/HQ	1277,5	619,5	293	260	270	2099,5	1748	300	1148	50	675	590	125	(1)	540	20	120	42	345	100	(2)	818	4	807
PMX(S/H)T	100/9	30	200L	758/GN	1352,5	694,5	293	260	270	2114,5	1767	300	1167	50	645	590	125	(1)	540	20	120	42	345	100	(2)	758	4	747
PMX(S/H)T	/9	37	225S	759/HQ	1352,5	694,5	293	260	270	2149,5	1798	300	1198	50	675	590	125	(1)	540	20	120	42	345	100	(2)	793	4	792

BGAM = Base and coupling
 * = Indicatives values according to the type of motor installed.
 ○ Motor in IE4 efficiency class according to EU REGULATION 2019/1781. Available in other efficiency classes for non-EU markets.

BGAMA = Рама и муфта
 * = Приблизит. значения в зависимости от марки двигателя.
 ○ Двигатель класса эффективности IE4 в соответствии с РЕГЛАМЕНТОМ ЕС 2019/1781. Имеются варианты в других классах эффективности для рынков за пределами ЕС.

BGAM = Base giunto e coprigiunto
 * = Valori indicativi in funzione della marca di motore utilizzato.
 ○ Motore in classe di efficienza IE4 in conformità al REGOLAMENTO UE2019/1781. Disponibili in altre classi di efficienza per mercati extra UE.

(1) PMXT=25 bar PMXST=25 bar PMXHT=40 bar
 (2) PMXT=40 bar PMXST=63 bar PMXHT=100 bar

(1) PMXT=25 бар PMXST=25 бар PMXHT=40 бар
 (2) PMXT=40 бар PMXST=63 бар PMXHT=100 бар

(1) PMXT=25 бар PMXST=25 бар PMXHT=40 бар
 (2) PMXT=40 бар PMXST=63 бар PMXHT=100 бар

Selection - dimensions and weights for base mounted electric pumps
 Подбор - габариты и вес электронасосов на раме
 Selezione - dimensioni e pesi elettropompe su base

COUPLINGS WITH STANDARDIZED ENCLOSED ELECTRIC MOTORS
 СОЕДИНЕНИЕ С НОРМАЛИЗОВАННЫМИ ЗАКРЫТЫМИ ЭЛЕКТРОДВИГАТЕЛЯМИ
 ACCORPIAMENTI CON MOTORI ELETTRICI CHIUSI NORMALIZZATI

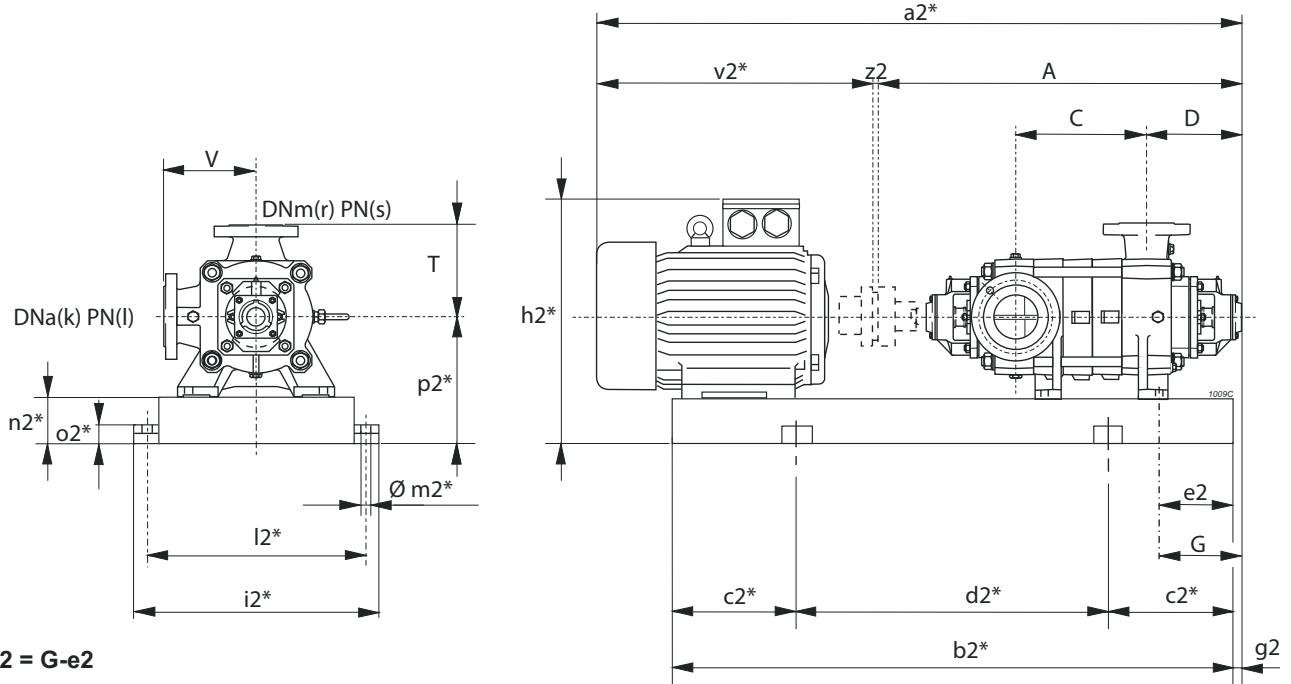

$g2 = G - e2$

* Valori indicativi in funzione della marca di motore utilizzato - Indicatives values according to the type of motor installed - Приблизительные значения в зависимости от марки двигателя

Pump Насос Помпа		Motor Двигатель Motore		BGAM	A	C	D	G	T	V	a2*	b2*	c2*	d2*	e2	h2*	i2*	k	l	l2*	m2*	n2*	o2*	p2*	r	s	v2*	z2	Weight Вес Peso	
Series Серия Serie	Type Тип Tipo	[kW]	Size Размер Grand.	Type Тип Tipo	[mm]																									[kg]
PMX(S/H)T	/9	45	225M	760/HQ	1352,5	694,5	293	260	270	270	2174,5	1823	300	1223	50	675	590	125	(1)	540	20	120	42	345	100	(2)	818	4	834	
PMX(S/H)T	/9	55	250M	761/IQ	1352,5	694,5	293	260	270	270	2236,5	1885	300	1285	70	745	635	125	(1)	585	20	120	42	370	100	(2)	880	4	963	
PMX(S/H)T	100/10	30	200L	762/GN	1427,5	769,5	293	260	270	270	2189,5	1842	300	1242	50	645	590	125	(1)	540	20	120	42	345	100	(2)	758	4	774	
PMX(S/H)T	/10	37	225S	763/HQ	1427,5	769,5	293	260	270	270	2224,5	1873	300	1273	50	675	590	125	(1)	540	20	120	42	345	100	(2)	793	4	819	
PMX(S/H)T	/10	45	225M	764/HQ	1427,5	769,5	293	260	270	270	2249,5	1898	300	1298	50	675	590	125	(1)	540	20	120	42	345	100	(2)	818	4	861	
PMX(S/H)T	/10	55	250M	765/IQ	1427,5	769,5	293	260	270	270	2311,5	1960	350	1260	70	745	635	125	(1)	585	20	120	42	370	100	(2)	880	4	990	
PMX(S/H)T	100/11	30	200L	766/GN	1502,5	844,5	293	260	270	270	2264,5	1917	300	1317	50	645	590	125	(1)	540	20	120	42	345	100	(2)	758	4	802	
PMX(S/H)T	/11	37	225S	767/HQ	1502,5	844,5	293	260	270	270	2299,5	1948	300	1348	50	675	590	125	(1)	540	20	120	42	345	100	(2)	793	4	847	
PMX(S/H)T	/11	45	225M	768/HQ	1502,5	844,5	293	260	270	270	2324,5	1973	350	1273	50	675	590	125	(1)	540	20	120	42	345	100	(2)	818	4	889	
PMX(S/H)T	/11	55	250M	769/IQ	1502,5	844,5	293	260	270	270	2386,5	2035	350	1335	70	745	635	125	(1)	585	20	120	42	370	100	(2)	880	4	1018	
PMX(S/H)T	/11	75	280S	770/IQ	1502,5	844,5	293	260	270	270	2519,5	2082	350	1382	70	815	695	125	(1)	645	20	140	42	420	100	(2)	1013	4	1186	

BGAM = Base and coupling

* = Indicatives values according to the type of motor installed.

○ Motor in IE4 efficiency class according to EU REGULATION 2019/1781. Available in other efficiency classes for non-EU markets.

- (1) PMXT=25 bar PMXST=25 bar PMXHT=40 bar
- (2) PMXT=40 bar PMXST=63 bar PMXHT=100 bar

BGAMA = Рама и муфта

* = Приблизит. значения в зависимости от марки двигателя.

○ Двигатель класса эффективности IE4 в соответствии с РЕГЛАМЕНТОМ ЕС 2019/1781. Имеются варианты в других классах эффективности для рынков за пределами ЕС.

- (1) PMXT=25 бар PMXST=25 бар PMXHT=40 бар
- (2) PMXT=40 бар PMXST=63 бар PMXHT=100 бар

BGAM = Base giunto e coprigiunto

* = Valori indicativi in funzione della marca di motore utilizzato.

○ Motore in classe di efficienza IE4 in conformità al REGOLAMENTO UE2019/1781. Disponibili in altre classi di efficienza per mercati extra UE.

- (1) PMXT=25 bar PMXST=25 bar PMXHT=40 bar
- (2) PMXT=40 bar PMXST=63 bar PMXHT=100 bar

Utilization field Область применения Campo di utilizzo ≥ 60% η		
Stage number: compatibly with the maximum pressure. Кол-во ступеней: совместимое с макс. давлением. Numero stadi: compatibilmente con la pressione massima di esercizio.		
Type Тип Tipo	MIN.	MAX.
PMXL T	2	10
PMXLST	2	10
PMXLHT	2	10
NB. For two-stage pumps only, reduce efficiency by one point. Только для двухступенчатых насосов - снизить КПД на 1 единицу Solamente per le pompe a due stadi, ridurre di un punto il rendimento.		

Wet moment of inertia J Момент инерции J мокрый Momento d'inerzia J bagnato J=1/4PD ² - [kg m ²]		
Impeller type Тип раб. колеса Girante tipo	PMXL(S/H)T125/1	For each additional stage Для каждой доп. ступени Per ogni stadio in più
Stainless steel Нержав. сталь Acciaio inox	0,1049	0,0918

Maximum permissible power Макс. допустимая мощность Massime potenze ammissibili	
Type Тип Tipo	N/n MAX.
PMXL T	0,25
PMXLST	0,25
PMXLHT	0,25
For seal limits and calculation formulas of the maximum permissible powers, see technical data section. Ограничения по уплотнениям и формулы расчета макс. допустимой мощности - см. раздел "Технические данные". Per i limiti tenute e le formule di calcolo delle massime potenze ammissibili, vedere sezione dati tecnici.	

PERFORMANCES EACH INTERMEDIATE STAGE
ХАРАКТЕРИСТИКИ ОДНОЙ СТУПЕНИ
PRESTAZIONI PER STADIO

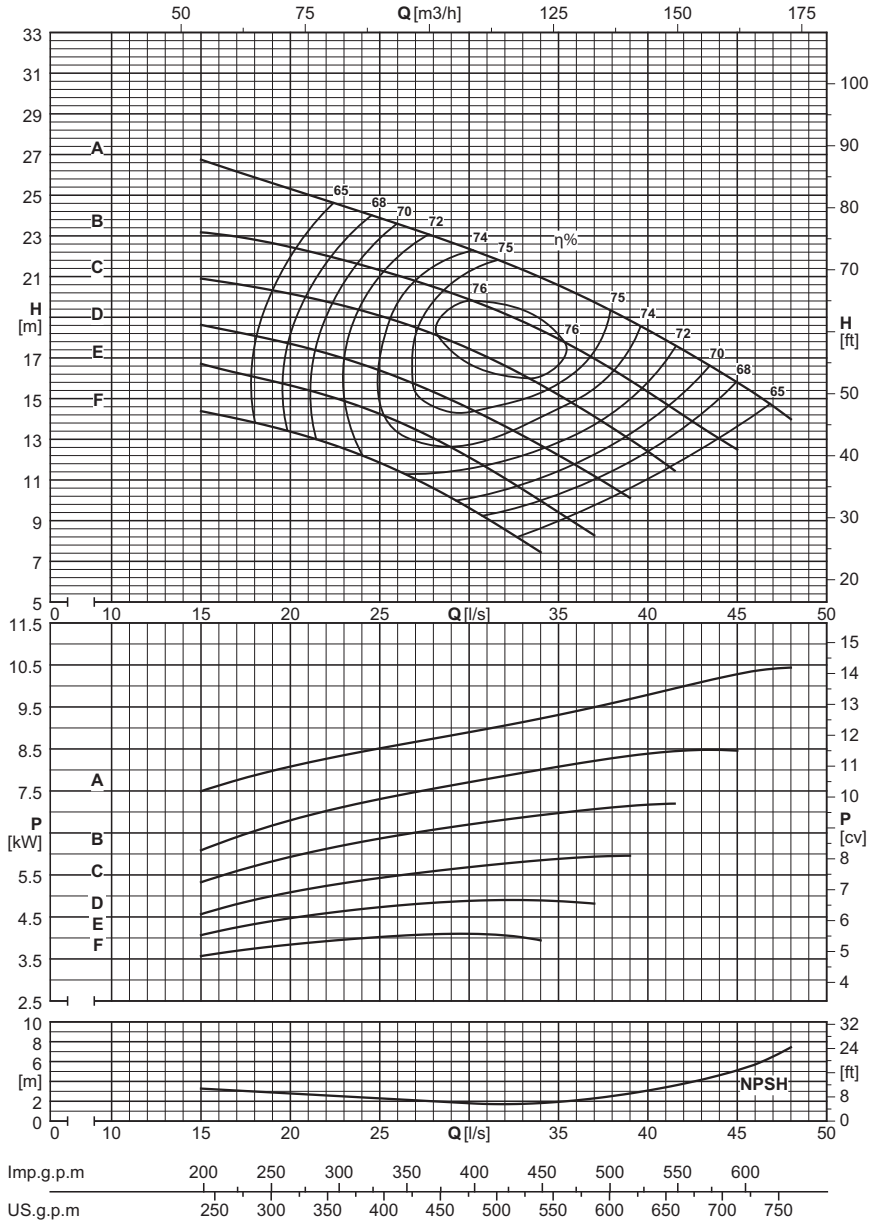

Capacity - Расход - Portata																				
Dna x DNm	Impeller type Тип раб. кол. / Girante tipo	[l/s]	0	16	18	20	22	24	26	28	30	32	34	36	38	40	42	44	46	48
		[m3/h]	0	57,6	64,8	72	79,2	86,4	93,6	100,8	108	115,2	122,4	129,6	136,8	144	151,2	158,4	165,6	172,8
		[l/min]	0	960	1080	1200	1320	1440	1560	1680	1800	1920	2040	2160	2280	2400	2520	2640	2760	2880

		PMXL(S/H)T125/1																		
150x125	F	[m]	16,5		14	13,5	13	12	11,5	10,5	9,6	8,6								
150x125	F	[kW]			3,7	3,8	3,9	4	4	4,1	4,1	4,1								
150x125	E	[m]	18,5		16,5	15,5	15	14,5	14	13,5	12	11	10	8,9						
150x125	E	[kW]			4,3	4,5	4,6	4,6	4,9	4,9	4,9	4,8	5	4,9						
150x125	D	[m]	20,5		17,5	17,5	17,5	16,5	16	15,5	14,5	13,5	12,5	11,5	10,5	9,9				
150x125	D	[kW]			5	5,1	5,1	5,4	5,4	5,6	5,7	5,9	5,9	5,8	6	6,1				
150x125	C	[m]	23,5		20,5	20	20	19	19	17,5	16,5	15,5	14,5	13,5	12,5	11,5				
150x125	C	[kW]			5,8	6,1	6,4	6,4	6,7	6,6	6,9	6,8	7	7,2	7,2	7,3				
150x125	B	[m]	26,5		22	21,5	22	21	20,5	19,5	19,5	18,5	17,5	16,5	15,5	14	13	12		
150x125	B	[kW]			6,9	7,2	7,1	7,4	7,6	7,9	7,8	8	8,2	8,2	8,3	8,5	8,6	8,6		
150x125	A	[m]	30,5			24,5	24	23	22,5	22,5	22	21	20	19,5	18,5	17,5	16	15		
150x125	A	[kW]				8,3	8,5	8,7	8,9	8,8	9	9,2	9,4	9,7	9,9	10,1	10,3			

		NPSH																	
		[m]	3,2	3	2,8	2,6	2,4	2,2	2	1,8	1,7	1,8	2,1	2,5	3,1	3,7	4,8	5,9	7,4

Utilization field Область применения Campo di utilizzo ≥ 60% η		
Stage number: compatibly with the maximum pressure. Кол-во ступеней: совместимое с макс. давлением. Numero stadi: compatibilmente con la pressione massima di esercizio.		
Type Тип Tipo	MIN.	MAX.
PMXL T	2	10
PMXLST	2	10
PMXLHT	2	10
NB. For two-stage pumps only, reduce efficiency by one point. Только для двухступенчатых насосов - снизить КПД на 1 единицу Solamente per le pompe a due stadi, ridurre di un punto il rendimento.		

Wet moment of inertia J Момент инерции J мокрый Momento d'inerzia J bagnato J=1/2 PD ² - [kg m ²]		
Impeller type Тип раб. колеса Girante tipo	PMXL(S/H)T125/1	For each additional stage Для каждой доп. ступени Per ogni stadio in più
Stainless steel Нержав. сталь Acciaio inox	0,1049	0,0918

Maximum permissible power Макс. допустимая мощность Massime potenze ammissibili	
Type Тип Tipo	N/n MAX.
PMXL T	0,25
PMXLST	0,25
PMXLHT	0,25
For seal limits and calculation formulas of the maximum permissible powers, see technical data section. Ограничения по уплотнениям и формулы расчета макс. допустимой мощности - см. раздел "Технические данные". Per i limiti tenute e le formule di calcolo delle massime potenze ammissibili, vedere sezione dati tecnici.	

PERFORMANCES EACH INTERMEDIATE STAGE
ХАРАКТЕРИСТИКИ ОДНОЙ СТУПЕНИ
PRESTAZIONI PER STADIO

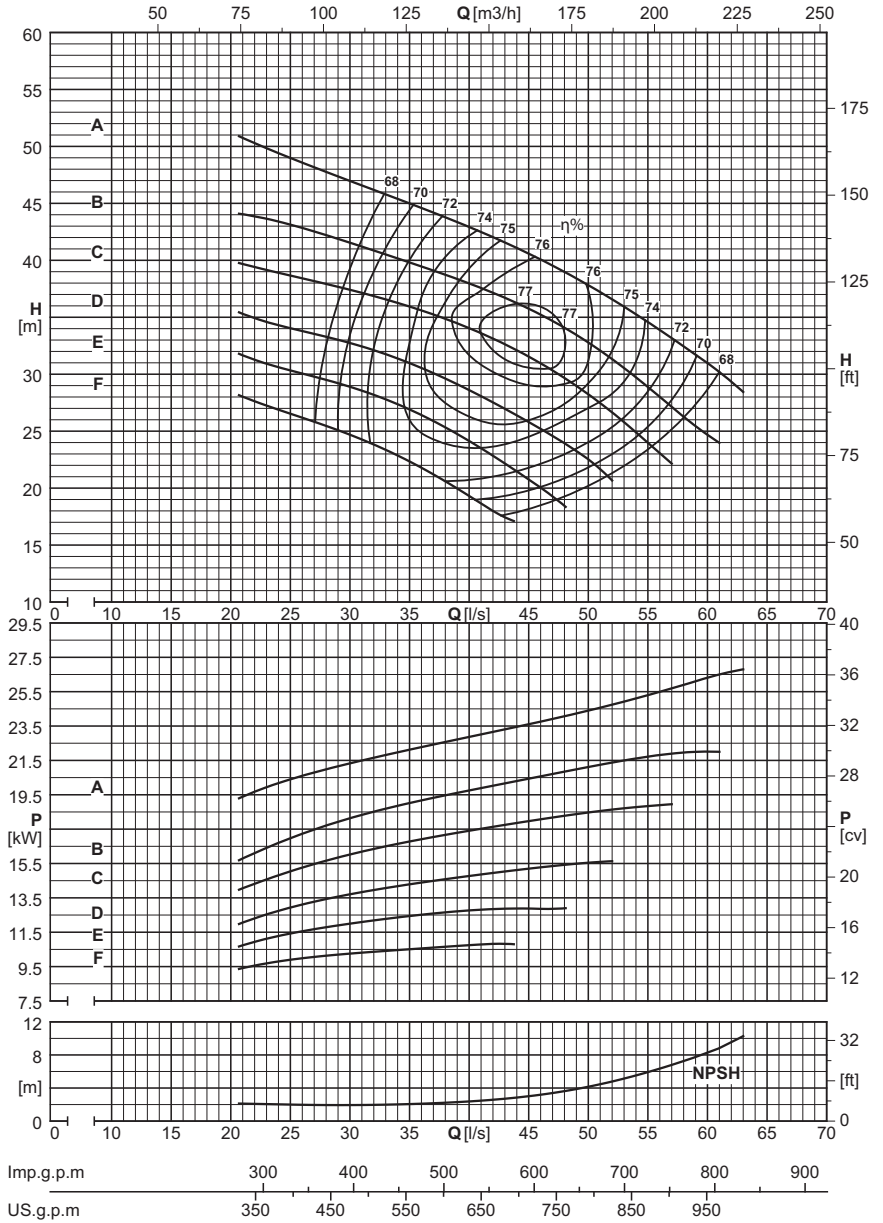

Dna x DNm	Impeller type Тип раб. кол. / Girante tipo	Capacity - Расход - Portata																				
		[l/s]	0	26	28	30	32	34	36	38	40	42	44	46	48	50	52	54	56	58	60	62
		[m ³ /h]	0	93,6	100,8	108	115,2	122,4	129,6	136,8	144	151,2	158,4	165,6	172,8	180	187,2	194,4	201,6	208,8	216	223,2
		[l/min]	0	1560	1680	1800	1920	2040	2160	2280	2400	2520	2640	2760	2880	3000	3120	3240	3360	3480	3600	3720

		PMXL(S/H)T125/1																					
150x125	F	[m]	31,5	26	25,5	25	23,5	23	22	20,5	19,5	18	17,5										
150x125	F	[kW]		10,1	10,1	10,1	10,5	10,5	10,4	10,7	10,7	10,7	10,9										
150x125	E	[m]	35,5	30,5	29,5	28,5	28,5	27	26,5	25,5	24	23	21,5	20	18,5	17,5							
150x125	E	[kW]		11,4	11,8	12,2	12,1	12,5	12,4	12,7	12,9	12,8	12,9	12,7	12,9	13,4							
150x125	D	[m]	39,5	33,5	32,5	33	32,5	31,5	30,5	30	28,5	27,5	26,5	25	24	22,5	20,5						
150x125	D	[kW]		13,2	13,7	13,5	13,9	14,2	14,5	14,4	14,6	14,9	15	15,5	15	15,5	15,5						
150x125	C	[m]	44,5	39	38,5	37,5	37,5	36,5	35,5	35	34,5	33,5	32	31	29,5	28,5	27	25	23,5	22			
150x125	C	[kW]		15	15,5	16	16,5	16,5	17	17	17,5	17,5	19	18	18,5	18,5	19	20	19	19,5			
150x125	B	[m]	50	44	41	40,5	40	39,5	39	38,5	38	37	36,5	35,5	34	33	31	29,5	27,5	26	24,5	23,5	
150x125	B	[kW]		17	18	18,5	19	19	19,5	19,5	20	20	20,5	20,5	21	21	21	21,5	21,5	21,5	21,5	22,5	
150x125	A	[m]	58			46,5	46,5	45,5	45	44	43,5	42,5	40,5	40	39	38	36,5	35,5	34	32,5	31	29	
150x125	A	[kW]				21,5	21,5	22	22	22,5	22,5	23	24	24	24,5	24,5	25	25	25,5	26	26	26,5	

		NPSH																					
	[m]	2	1,9	1,9	2	2	2,1	2,2	2,4	2,6	2,9	3,2	3,6	4,2	4,8	5,6	6,5	7,5	8,6	9			

2200 n [min⁻¹]

Utilization field Область применения Campo di utilizzo ≥ 60% η		
Stage number: compatibly with the maximum pressure. Кол-во ступеней: совместимое с макс. давлением. Numero stadi: compatibilmente con la pressione massima di esercizio.		
Type Тип Tipo	MIN.	MAX.
PMXLT	2	8
PMXLST	2	8
PMXLHT	2	10
NB. For two-stage pumps only, reduce efficiency by one point. Только для двухступенчатых насосов - снизить КПД на 1 единицу Solamente per le pompe a due stadi, ridurre di un punto il rendimento.		

Wet moment of inertia J Момент инерции J мокрый Momento d'inerzia J bagnato J=¼PD ² - [kg m ²]		
Impeller type Тип раб. колеса Girante tipo	PMXL(S/H)T125/1	For each additional stage Для каждой доп. ступени Per ogni stadio in più
Stainless steel Нержав. сталь Acciaio inox	0,1049	0,0918

Maximum permissible power Макс. допустимая мощность Massime potenze ammissibili	
Type Тип Tipo	N/n MAX.
PMXLT	0,25
PMXLST	0,25
PMXLHT	0,25
For seal limits and calculation formulas of the maximum permissible powers, see technical data section. Ограничения по уплотнениям и формулы расчета макс. допустимой мощности - см. раздел "Технические данные". Per i limiti tenute e le formule di calcolo delle massime potenze ammissibili, vedere sezione dati tecnici.	

PERFORMANCES EACH INTERMEDIATE STAGE
ХАРАКТЕРИСТИКИ ОДНОЙ СТУПЕНИ
PRESTAZIONI PER STADIO

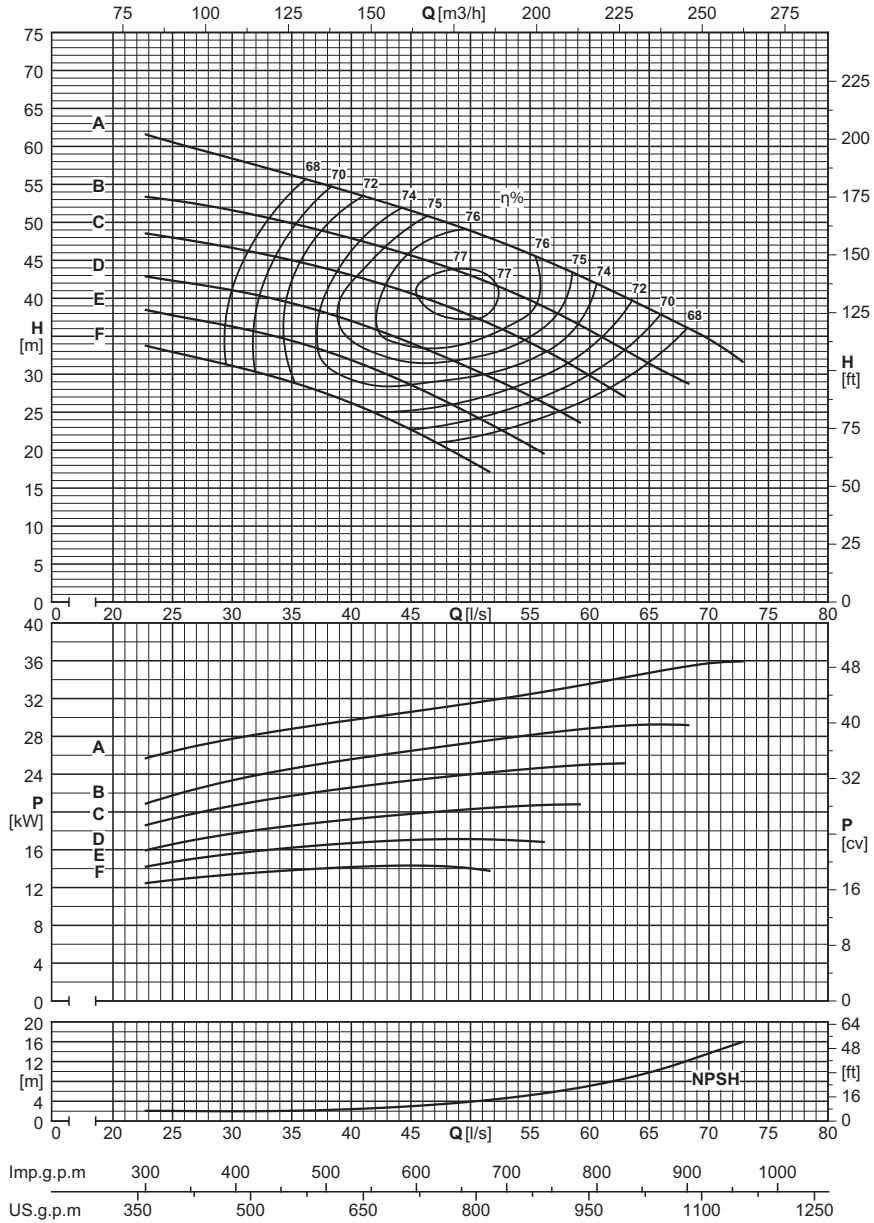

Capacity - Расход - Portata

Dna x Dnm	Impeller type Тип раб. кол. Girante tipo	Capacity - Расход - Portata																						
		[l/s]	0	28	30	32	34	36	38	40	42	44	46	48	50	52	54	56	58	60	62	64	66	68
		[m³/h]	0	100,8	108	115,2	122,4	129,6	136,8	144	151,2	158,4	165,6	172,8	180	187,2	194,4	201,6	208,8	216	223,2	230,4	237,6	244,8
		[l/min]	0	1680	1800	1920	2040	2160	2280	2400	2520	2640	2760	2880	3000	3120	3240	3360	3480	3600	3720	3840	3960	4080

PMXL(S/H)T125/1

150x125	F	[m]	38	31,5	31,5	30	29	28,5	27,5	26	25	23,5	22	20	18,5									
150x125	F	[kW]		13,4	13,3	13,6	14	13,8	14,1	14,3	14,1	14,3	14,5	14	14									
150x125	E	[m]	43	37	36	35	34,5	34,5	33	32	30,5	29,5	28	26,5	24,5	23	21,5	19,5	19					
150x125	E	[kW]		15	15,5	16,5	16,5	16	16,5	16,5	17	17,5	17	17,5	17	17	17	17,5						
150x125	D	[m]	47,5	42	41,5	41	40	40	38	37,5	36	34,5	33,5	32	31	29,5	29	26,5	25,5	23,5				
150x125	D	[kW]		17	17,5	18	18,5	18,5	19	19	19,5	19,5	20	20	20,5	20,5	21	21	21	21				
150x125	C	[m]	54		45,5	45	44,5	44	43,5	43	42	41	40	40	38	36,5	35	33	31,5	29,5	27,5	26,5		
150x125	C	[kW]			21	21,5	22	22	22,5	22,5	23,5	23	23,5	23,5	24	24	24,5	24,5	24,5	25	25,5			
150x125	B	[m]	60		51	51	51	50	48	47,5	47,5	46,5	45,5	44,5	42,5	41,5	40,5	40	37,5	35,5	34,5	32,5	30,5	29
150x125	B	[kW]			23,5	23,5	24,5	24,5	25,5	26	26,5	26	26,5	26,5	27,5	28	29	28	28,5	28,5	29,5	29,5	29,5	29
150x125	A	[m]	70			59	55	55	55	55	52	51	51	50	48,5	47,5	46,5	45,5	43,5	42,5	41	39	39	36,5
150x125	A	[kW]				27,5	29	30	30	29	30,5	30,5	30,5	30,5	32	32	32	32,5	33,5	33,5	34	34	35,5	35,5

NPSH

[m]	2	2	2	2	2,1	2,3	2,4	2,6	2,9	3,2	3,5	3,9	4,3	4,9	5,6	6,5	7	8,2	8,9	10,4	12,2
-----	---	---	---	---	-----	-----	-----	-----	-----	-----	-----	-----	-----	-----	-----	-----	---	-----	-----	------	------

Utilization field Область применения Campo di utilizzo ≥ 60% η		
Stage number: compatibly with the maximum pressure. Кол-во ступеней: совместимое с макс. давлением. Numero stadi: compatibilmente con la pressione massima di esercizio.		
Type Тип Tipo	MIN.	MAX.
PMXL T	2	5
PMXLST	2	5
PMXLHT	2	8
NB. For two-stage pumps only, reduce efficiency by one point. Только для двухступенчатых насосов - снизить КПД на 1 единицу Solamente per le pompe a due stadi, ridurre di un punto il rendimento.		

Wet moment of inertia J Момент инерции J мокрый Momento d'inerzia J bagnato J=1/2PD ² - [kg m ²]		
Impeller type Тип раб. колеса Girante tipo	PMXL(S/H)T125/1	For each additional stage Для каждой доп. ступени Per ogni stadio in più
Stainless steel Нержав. сталь Acciaio inox	0,1049	0,0918

Maximum permissible power Макс. допустимая мощность Massime potenze ammissibili	
Type Тип Tipo	N/n MAX.
PMXL T	0,25
PMXLST	0,25
PMXLHT	0,25
For seal limits and calculation formulas of the maximum permissible powers, see technical data section. Ограничения по уплотнениям и формулы расчета макс. допустимой мощности - см. раздел "Технические данные". Per i limiti tenute e le formule di calcolo delle massime potenze ammissibili, vedere sezione dati tecnici.	

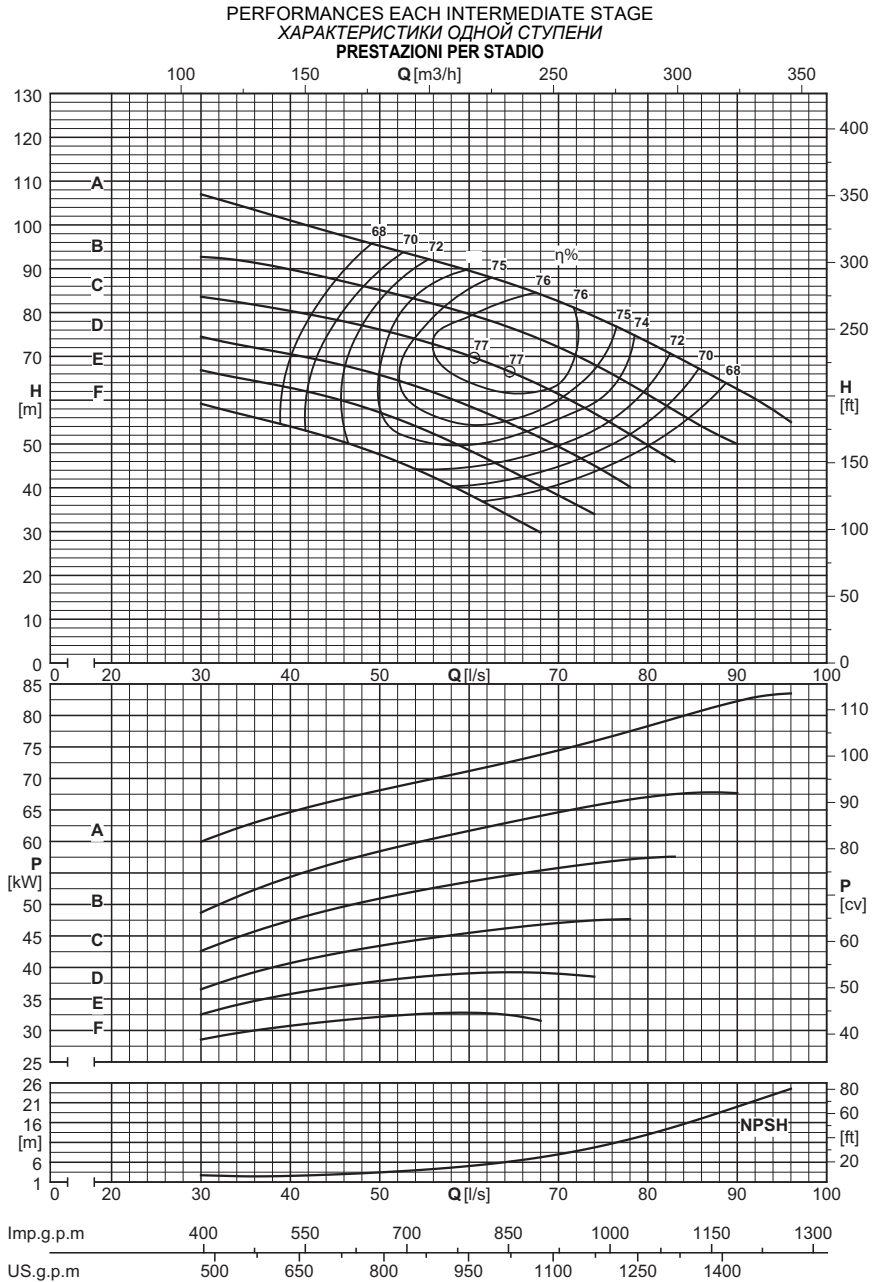

Dna x DNm	Impeller type Тип раб. кол. Girante tipo	Capacity - Расход - Portata																
		[l/s]	0	32	36	40	44	48	52	56	60	64	68	72	76	80	84	88
		[m ³ /h]	0	115,2	129,6	144	158,4	172,8	187,2	201,6	216	230,4	244,8	259,2	273,6	288	302,4	316,8
		[l/min]	0	1920	2160	2400	2640	2880	3120	3360	3600	3840	4080	4320	4560	4800	5040	5280

		PMXL(S/H)T125/1																
150x125	F	[m]	66	56	54	51	49	46,5	42,5	38,5	34							
150x125	F	[kW]		30	30,5	31,5	32	32,5	32,5	33	32,5							
150x125	E	[m]	74	65	62	60	58	55	52	48,5	44,5	41	36,5	33				
150x125	E	[kW]		34	36,5	37	37	39	40	40	39	39,5	40	39,5				
150x125	D	[m]	82		70	70	66	65	61	58	55	51	47	43	39			
150x125	D	[kW]			40,5	41	43	43,5	45	45,5	47	47	47	48	49			
150x125	C	[m]	93		82	78	75	75	72	70	66	63	59	55	49,5	45,5		
150x125	C	[kW]			46,5	50	51,5	51,5	53	53	55	55	56,5	57,5	57,5	58,5		
150x125	B	[m]	105		88	85	87	84	81	78	77	73	70	65	61	56	52	
150x125	B	[kW]			55	57,5	57	60	61	63	62,5	64	66	65,5	66,5	68	68,5	
150x125	A	[m]	122			98	95	92	90	90	87	84	80	77	73	68	64	
150x125	A	[kW]				66,5	68	70	71,5	70	72	73,5	75	77	79	79	81	
		NPSH																
		[m]		2,6	2,4	2,6	2,9	3,2	3,7	4,3	5,1	6	7,3	8,8	10,5	13,1	15,5	19,1

Overall dimensions and weights
Общие забариты и вес
Dimensioni di ingombro e pesi

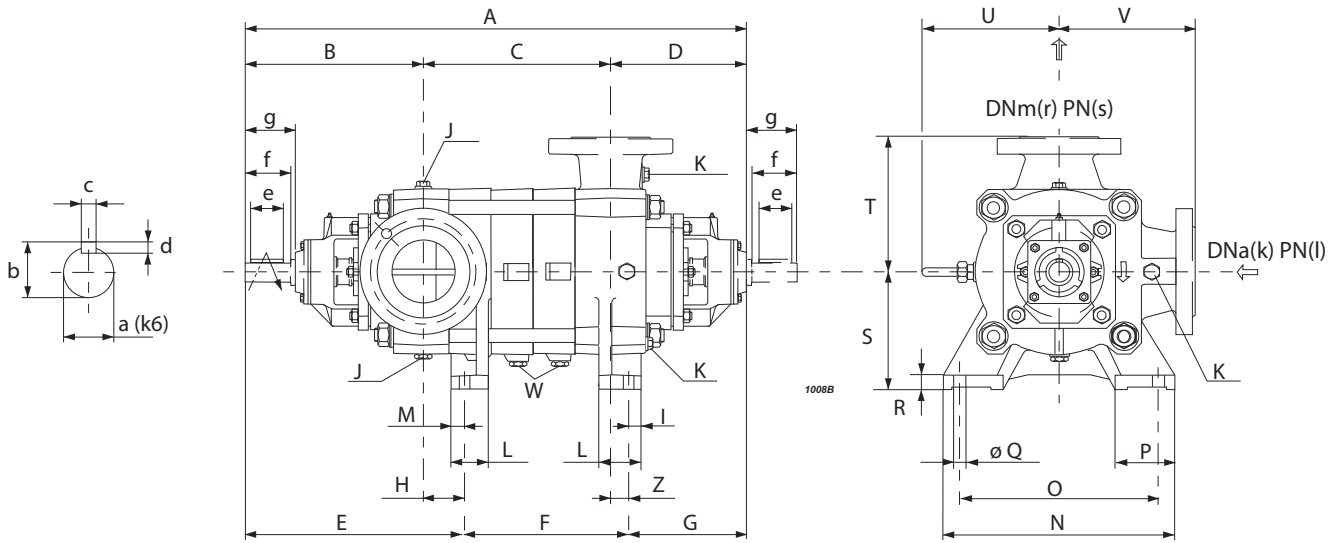

Series Серия Serie	Type Тип Tipo	A	B	C	D	E	F	G	H	S	T	U	V	Z	Weight Вес Peso
		[mm]													
PMXL(S/H)T	125/2	1033	451	245	337	539	200	294	88	280	320	326	320	43	462
PMXL(S/H)T	125/3	1133	451	345	337	539	300	294	88	280	320	326	320	43	514
PMXL(S/H)T	125/4	1233	451	445	337	539	400	294	88	280	320	326	320	43	565
PMXL(S/H)T	125/5	1333	451	545	337	539	500	294	88	280	320	326	320	43	616
PMXL(S/H)T	125/6	1433	451	645	337	539	600	294	88	280	320	326	320	43	667
PMXL(S/H)T	125/7	1533	451	745	337	539	700	294	88	280	320	326	320	43	718
PMXL(S/H)T	125/8	1633	451	845	337	539	800	294	88	280	320	326	320	43	770
PMXL(S/H)T	125/9	1733	451	945	337	539	900	294	88	280	320	326	320	43	821
PMXL(S/H)T	125/10	1833	451	1045	337	539	1000	294	88	280	320	326	320	43	872

Foot dimensions Размеры ножек Dimensioni dei piedi							
I	L	M	N	O	P	Q	R
[mm]							
30	100	29,5	570	460	145	24	35

Shaft projection Выступ вала Sporgenza d'albero						
a	b	c	d	e	f	g
[mm]						
45	48,5	14	9	100	110	125

Type Тип Tipo	Flanges Фланцы Flange			
	(k) DNa	(l) PN	(r) DNm	(s) PN
	[mm]	[bar]	[mm]	[bar]
PMXLT	150	25	125	40
PMXLST	150	25	125	63
PMXLHT	150	40	125	100

Plugs Пробки Tappi		
J	K	W
G3/4	G1/2	G1/4

Selection - dimensions and weights for base mounted electric pumps
 Подбор - габариты и вес электронасосов на раме
 Selezione - dimensioni e pesi elettropompe su base

COUPLINGS WITH STANDARDIZED ENCLOSED ELECTRIC MOTORS / СОЕДИНЕНИЕ С НОРМАЛИЗОВАННЫМИ ЗАКРЫТЫМИ ЭЛЕКТРОДВИГАТЕЛЯМИ / ACCOPPIAMENTI CON MOTORI ELETTRICI CHIUSI NORMALIZZATI

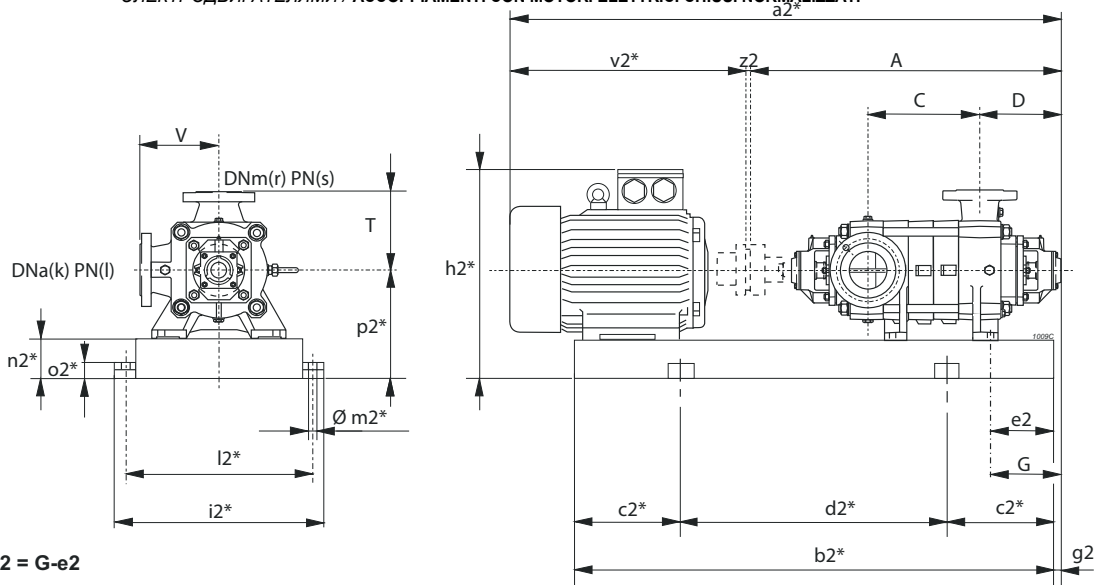

$g2 = G - e2$

* Valori indicativi in funzione della marca di motore utilizzato - Indicatives values according to the type of motor installed - Приблизительные значения в зависимости от марки двигателя

Pump Насос Ромпа	Motor Двигатель Motore	BGAM	A	C	D	G	T	V	a2*	b2*	c2*	d2*	e2	h2*	i2*	k	l	l2*	m2*	n2*	o2*	p2*	r	s	v2*	z2	Weight Вес Peso		
																											[kg]		
Series Серия Serie	Type Тип Tipo	[kW]	Size Размер Grand.	Type Тип Tipo	[mm]																				[kg]				
PMXL(S/H)T	125/2	75	280S	802/HR	1033	245	337	294	320	320	2037	1568	250	1068	60	815	700	150	(1)	650	20	140	42	420	125	(2)	1000	4	1101
PMXL(S/H)T	/2	90	280M	801/HR	1033	245	337	294	320	320	2088	1619	250	1119	60	815	700	150	(1)	650	20	140	42	420	125	(2)	1051	4	1230
PMXL(S/H)T	/2	110	315S	800/IR	1033	245	337	294	320	320	2218	1695	300	1095	90	1030	780	150	(1)	730	22	160	50	475	125	(2)	1181	4	1543
PMXL(S/H)T	/2	132	315M	335/IR	1033	245	337	294	320	320	2328	1805	300	1205	90	1030	780	150	(1)	730	22	160	50	475	125	(2)	1291	4	1619
PMXL(S/H)T	/2	160	315L	335/IR	1033	245	337	294	320	320	2328	1805	300	1205	90	1030	780	150	(1)	730	22	160	50	475	125	(2)	1291	4	1697
PMXL(S/H)T	/2	200	315L	336/IE4/LR	1033	245	337	294	320	320	2418	1895	300	1295	198	1030	780	150	(1)	730	22	160	50	475	125	(2)	1381	4	1831
PMXL(S/H)T	125/3	110	315S	805/IR	1133	345	337	294	320	320	2318	1795	300	1195	90	1030	780	150	(1)	730	22	160	50	475	125	(2)	1181	4	1594
PMXL(S/H)T	/3	132	315M	804/IR	1133	345	337	294	320	320	2428	1854	300	1254	90	1030	780	150	(1)	730	22	160	50	475	125	(2)	1291	4	1668
PMXL(S/H)T	/3	160	315L	338/LR	1133	345	337	294	320	320	2428	1905	300	1305	90	1030	780	150	(1)	730	22	160	50	475	125	(2)	1291	4	1753
PMXL(S/H)T	/3	200	315L	338/IE4/LR	1133	345	337	294	320	320	2518	1995	350	1295	198	1030	780	150	(1)	730	22	160	50	475	125	(2)	1381	4	1882
PMXL(S/H)T	/3	250	355M	339/LR	1133	345	337	294	320	320	2663	2049	350	1349	110	1136	880	150	(1)	830	22	180	50	535	125	(2)	1526	4	2298
PMXL(S/H)T	/3	280	355L	339/LR	1133	345	337	294	320	320	2663	2049	350	1349	110	1136	880	150	(1)	830	22	180	50	535	125	(2)	1526	4	2423
PMXL(S/H)T	125/4	160	315L	807/IR	1233	445	337	294	320	320	2528	2005	350	1305	90	1030	780	150	(1)	730	22	160	50	475	125	(2)	1291	4	1799
PMXL(S/H)T	/4	200	315L	806/IE4/LR	1233	445	337	294	320	320	2618	2095	350	1395	198	1030	780	150	(1)	730	22	160	50	475	125	(2)	1381	4	1933
PMXL(S/H)T	/4	250	355M	340/LR	1233	445	337	294	320	320	2763	2079	350	1379	110	1136	880	150	(1)	830	22	180	50	535	125	(2)	1526	4	2349
PMXL(S/H)T	/4	280	355L	340/MR	1233	445	337	294	320	320	2763	2149	350	1449	110	1136	880	150	(1)	830	22	180	50	535	125	(2)	1526	4	2478
PMXL(S/H)T	/4	315	355L	340/MR	1233	445	337	294	320	320	2763	2149	350	1449	110	1136	880	150	(1)	830	22	180	50	535	125	(2)	1526	4	2478
PMXL(S/H)T	/4	355	355L	340/MR	1233	445	337	294	320	320	2763	2149	350	1449	110	1136	880	150	(1)	830	22	180	50	535	125	(2)	1526	4	2468
PMXL(S/H)T	125/5	200	315L	809/IE4/LR	1333	545	337	294	320	320	2718	2195	350	1495	198	1030	780	150	(1)	730	22	160	50	475	125	(2)	1381	4	1983
PMXL(S/H)T	/5	250	355M	808/LR	1333	545	337	294	320	320	2863	2179	350	1479	110	1136	880	150	(1)	830	22	180	50	535	125	(2)	1526	4	2398
PMXL(S/H)T	/5	280	355L	341/MR	1333	545	337	294	320	320	2863	2249	350	1549	110	1136	880	150	(1)	830	22	180	50	535	125	(2)	1526	4	2530
PMXL(S/H)T	/5	315	355L	341/MR	1333	545	337	294	320	320	2863	2249	350	1549	110	1136	880	150	(1)	830	22	180	50	535	125	(2)	1526	4	2530
PMXL(S/H)T	/5	355	355L	341/MR	1333	545	337	294	320	320	2863	2249	350	1549	110	1136	880	150	(1)	830	22	180	50	535	125	(2)	1526	4	2520
PMXL(H)T	125/6	250	355M	4000/LR	1433	645	337	294	320	320	2963	2349	400	1549	110	1136	880	150	(1)	830	22	180	50	535	125	(2)	1526	4	2452
PMXL(H)T	/6	280	355L	4000/LR	1433	645	337	294	320	320	2963	2349	400	1549	110	1136	880	150	(1)	830	22	180	50	535	125	(2)	1526	4	2577
PMXL(H)T	/6	315	355L	4000/MR	1433	645	337	294	320	320	2963	2349	400	1549	110	1136	880	150	(1)	830	22	180	50	535	125	(2)	1526	4	2581
PMXL(H)T	/6	355	355L	4000/MR	1433	645	337	294	320	320	2963	2349	400	1549	110	1136	880	150	(1)	830	22	180	50	535	125	(2)	1526	4	2571
PMXL(H)T	125/7	250	355M	4001/LR	1533	745	337	294	320	320	3063	2449	400	1649	110	1136	880	150	(1)	830	22	180	50	535	125	(2)	1526	4	2504
PMXL(H)T	/7	280	355L	4001/LR	1533	745	337	294	320	320	3063	2449	400	1649	110	1136	880	150	(1)	830	22	180	50	535	125	(2)	1526	4	2629
PMXL(H)T	/7	315	355L	4001/MR	1533	745	337	294	320	320	3063	2449	400	1649	110	1136	880	150	(1)	830	22	180	50	535	125	(2)	1526	4	2633
PMXL(H)T	/7	355	355L	4001/MR	1533	745	337	294	320	320	3063	2449	400	1649	110	1136	880	150	(1)	830	22	180	50	535	125	(2)	1526	4	2623
PMXL(H)T	125/8	280	355L	4002/MR	1633	845	337	294	320	320	3163	2549	400	1749	110	1136	880	150	(1)	830	22	180	50	535	125	(2)	1526	4	2684
PMXL(H)T	/8	315	355L	4002/MR	1633	845	337	294	320	320	3163	2549	400	1749	110	1136	880	150	(1)	830	22	180	50	535	125	(2)	1526	4	2684
PMXL(H)T	/8	355	355L	4002/MR	1633	845	337	294	320	320	3163	2549	400	1749	110	1136	880	150	(1)	830	22	180	50	535	125	(2)	1526	4	2674

Contact the sales network for couplings exceeding 355 kW.

BGAM = Base and coupling

* = Indicatives values according to the type of motor installed.

○ Motor in IE4 efficiency class according to EU REGULATION 2019/1781. Available in other efficiency classes for non-EU markets.

- (1) PMXL T=25 bar PMXLST=25 bar PMXLHT=40 bar
 (2) PMXL T=40 bar PMXLST=63 bar PMXLHT=100 bar

В случае муфт мощностью более 355 кВт обратитесь в нашу коммерческую сеть.

BGAMA = Рама и муфта

* = Приблизит. значения в зависимости от марки двигателя.

○ Двигатель класса эффективности IE4 в соответствии с РЕГУЛЯЦИОННОМ ЕС 2019/1781. Имеются варианты в других классах эффективности для рынков за пределами ЕС.

- (1) PMXL T=25 бар PMXLST=25 бар PMXLHT=40 бар
 (2) PMXL T=40 бар PMXLST=63 бар PMXLHT=100 бар

Per accoppiamenti superiori ai 355 kW, contattare la rete di vendita.

BGAM = Base giunto e coprigiunto

* = Valori indicativi in funzione della marca di motore utilizzato.

○ Motore in classe di efficienza IE4 in conformità al REGOLAMENTO UE2019/1781. Disponibili in altre classi di efficienza per mercati extra UE.

- (1) PMXL T=25 bar PMXLST=25 bar PMXLHT=40 bar
 (2) PMXL T=40 bar PMXLST=63 bar PMXLHT=100 bar



COUPLINGS WITH STANDARDIZED ENCLOSED ELECTRIC MOTORS
СОЕДИНЕНИЕ С НОРМАЛИЗОВАННЫМИ ЗАКРЫТЫМИ ЭЛЕКТРОДВИГАТЕЛЯМИ
ACCOPIAMENTI CON MOTORI ELETTRICI CHIUSI NORMALIZZATI

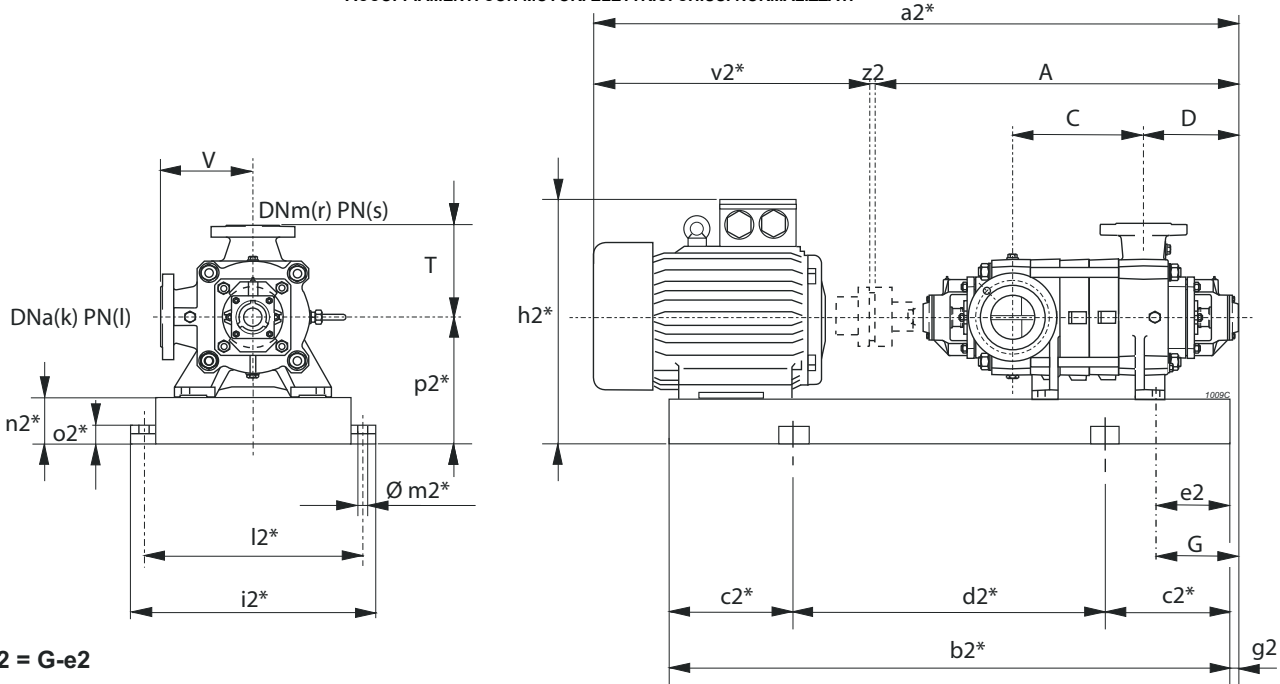

$g2 = G - e2$

* Valori indicativi in funzione della marca di motore utilizzato - Indicatives values according to the type of motor installed - Приблизительные значения в зависимости от марки двигателя

Pump Насос Помпа		Motor Двигатель Motore		BGAM	A	C	D	G	T	V	a2*	b2*	c2*	d2*	e2	h2*	i2*	k	l	l2*	m2*	n2*	o2*	p2*	r	s	v2*	z2	Weight Вес Peso	
Series Серия Serie	Type Тип Tipo	[kW]	Size Размер Grand.	Type Тип Tipo	[mm]																									[kg]
PMXL(S/H)T	125/2	11	160M	870/EP	1033	245	337	294	320	320	1664	1296	200	896	60	671	700	150	(1)	650	20	140	42	420	125	(2)	627	4	671	
PMXL(S/H)T	/2	15	160L	345/EP	1033	245	337	294	320	320	1664	1340	200	940	60	671	700	150	(1)	650	20	140	42	420	125	(2)	627	4	684	
PMXL(S/H)T	/2	18,5	180M	346/FP	1033	245	337	294	320	320	1702	1350	250	850	60	690	700	150	(1)	650	20	140	42	420	125	(2)	665	4	765	
PMXL(S/H)T	/2	22	180L	347/FP	1033	245	337	294	320	320	1742	1388	250	888	60	690	700	150	(1)	650	20	140	42	420	125	(2)	705	4	786	
PMXL(S/H)T	125/3	15	160L	811/IR	1133	345	337	294	320	320	1764	1440	250	940	60	671	700	150	(1)	650	20	140	42	420	125	(2)	627	4	743	
PMXL(S/H)T	/3	18,5	180M	850/FP	1133	345	337	294	320	320	1802	1450	250	950	60	690	700	150	(1)	650	20	140	42	420	125	(2)	665	4	815	
PMXL(S/H)T	/3	22	180L	849/FP	1133	345	337	294	320	320	1842	1488	250	988	60	690	700	150	(1)	650	20	140	42	420	125	(2)	705	4	836	
PMXL(S/H)T	/3	30	200L	349/GP	1133	345	337	294	320	320	1895	1523	250	1023	60	720	700	150	(1)	650	20	140	42	420	125	(2)	758	4	871	
PMXL(S/H)T	/3	37	225S	350/HR	1133	345	337	294	320	320	1930	1554	250	1054	60	750	700	150	(1)	650	20	140	42	420	125	(2)	793	4	886	
PMXL(S/H)T	125/4	18,5	180M	812/FP	1233	445	337	294	320	320	1902	1550	250	1050	60	690	700	150	(1)	650	20	140	42	420	125	(2)	665	4	865	
PMXL(S/H)T	/4	22	180L	871/FP	1233	445	337	294	320	320	1942	1588	250	1088	60	690	700	150	(1)	650	20	140	42	420	125	(2)	705	4	886	
PMXL(S/H)T	/4	30	200L	352/GP	1233	445	337	294	320	320	1995	1623	250	1123	60	720	700	150	(1)	650	20	140	42	420	125	(2)	758	4	921	
PMXL(S/H)T	/4	37	225S	471/HR	1233	445	337	294	320	320	2030	1654	300	1054	60	750	700	150	(1)	650	20	140	42	420	125	(2)	793	4	937	
PMXL(S/H)T	/4	45	225M	472/HR	1233	445	337	294	320	320	2055	1679	300	1079	60	750	700	150	(1)	650	20	140	42	420	125	(2)	818	4	979	
PMXL(S/H)T	125/5	22	180L	814/FP	1333	545	337	294	320	320	2042	1688	300	1088	60	690	700	150	(1)	650	20	140	42	420	125	(2)	705	4	936	
PMXL(S/H)T	/5	30	200L	851/GP	1333	545	337	294	320	320	2095	1723	300	1123	60	720	700	150	(1)	650	20	140	42	420	125	(2)	758	4	971	
PMXL(S/H)T	/5	37	225S	813/HR	1333	545	337	294	320	320	2130	1754	300	1154	60	750	700	150	(1)	650	20	140	42	420	125	(2)	793	4	987	
PMXL(S/H)T	/5	45	225M	475/HR	1333	545	337	294	320	320	2155	1779	300	1179	60	750	700	150	(1)	650	20	140	42	420	125	(2)	818	4	1029	
PMXL(S/H)T	/5	55	250M	476/IR	1333	545	337	294	320	320	2217	1821	300	1221	60	795	700	150	(1)	650	20	140	42	420	125	(2)	880	4	1153	
PMXL(S/H)T	125/6	30	200L	815/GP	1433	645	337	294	320	320	2195	1823	300	1223	60	720	700	150	(1)	650	20	140	42	420	125	(2)	758	4	1021	
PMXL(S/H)T	/6	37	225S	852/HR	1433	645	337	294	320	320	2230	1854	300	1254	60	750	700	150	(1)	650	20	140	42	420	125	(2)	793	4	1037	
PMXL(S/H)T	/6	45	225M	478/HR	1433	645	337	294	320	320	2255	1879	300	1279	60	750	700	150	(1)	650	20	140	42	420	125	(2)	818	4	1080	
PMXL(S/H)T	/6	55	250M	479/IR	1433	645	337	294	320	320	2317	1921	300	1321	60	795	700	150	(1)	650	20	140	42	420	125	(2)	880	4	1203	
PMXL(S/H)T	/6	75	280S	480/IR	1433	645	337	294	320	320	2450	1968	350	1268	60	815	700	150	(1)	650	20	140	42	420	125	(2)	1013	4	1344	
PMXL(S/H)T	125/7	30	200L	817/GP	1533	745	337	294	320	320	2295	1923	300	1323	60	720	700	150	(1)	650	20	140	42	420	125	(2)	758	4	1072	
PMXL(S/H)T	/7	37	225S	853/HR	1533	745	337	294	320	320	2330	1954	350	1254	60	750	700	150	(1)	650	20	140	42	420	125	(2)	793	4	1087	
PMXL(S/H)T	/7	45	225M	816/HR	1533	745	337	294	320	320	2355	1979	350	1279	60	750	700	150	(1)	650	20	140	42	420	125	(2)	818	4	1130	
PMXL(S/H)T	/7	55	250M	482/IR	1533	745	337	294	320	320	2417	2021	350	1321	60	795	700	150	(1)	650	20	140	42	420	125	(2)	880	4	1253	
PMXL(S/H)T	/7	75	280S	483/IR	1533	745	337	294	320	320	2550	2068	350	1368	60	815	700	150	(1)	650	20	140	42	420	125	(2)	1013	4	1395	
PMXL(S/H)T	/7	90	280M	484/LR	1533	745	337	294	320	320	2601	2119	350	1419	60	815	700	150	(1)	650	20	140	42	420	125	(2)	1064	4	1464	

BGAM = Base and coupling

* = Indicatives values according to the type of motor installed.

○ Motor in IE4 efficiency class according to EU REGULATION 2019/1781. Available in other efficiency classes for non-EU markets.

BGAMA = Рама и муфта

* = Приблизит. значения в зависимости от марки двигателя.

○ Двигатель класса эффективности IE4 в соответствии с РЕГЛАМЕНТОМ ЕС 2019/1781. Имеются варианты в других классах эффективности для рынков за пределами ЕС.

BGAM = Base giunto e coprigiunto

* = Valori indicativi in funzione della marca di motore utilizzato.

○ Motore in classe di efficienza IE4 in conformità al REGOLAMENTO UE2019/1781. Disponibili in altre classi di efficienza per mercati extra UE.

(1) PMXLT=25 bar PMXLST=25 bar PMXLHT=40 bar
(2) PMXLT=40 bar PMXLST=63 bar PMXLHT=100 bar

(1) PMXLT=25 бар PMXLST=25 бар PMXLHT=40 бар
(2) PMXLT=40 бар PMXLST=63 бар PMXLHT=100 бар

(1) PMXLT=25 bar PMXLST=25 bar PMXLHT=40 bar
(2) PMXLT=40 bar PMXLST=63 bar PMXLHT=100 bar

Selection - dimensions and weights for base mounted electric pumps
 Подбор - заготовки и вес электронасосов на раме
 Selezione - dimensioni e pesi elettropompe su base

COUPLINGS WITH STANDARDIZED ENCLOSED ELECTRIC MOTORS
 СОЕДИНЕНИЕ С НОРМАЛИЗОВАННЫМИ ЗАКРЫТЫМИ ЭЛЕКТРОДВИГАТЕЛЯМИ
 ACCORPIAMENTI CON MOTORI ELETTRICI CHIUSI NORMALIZZATI

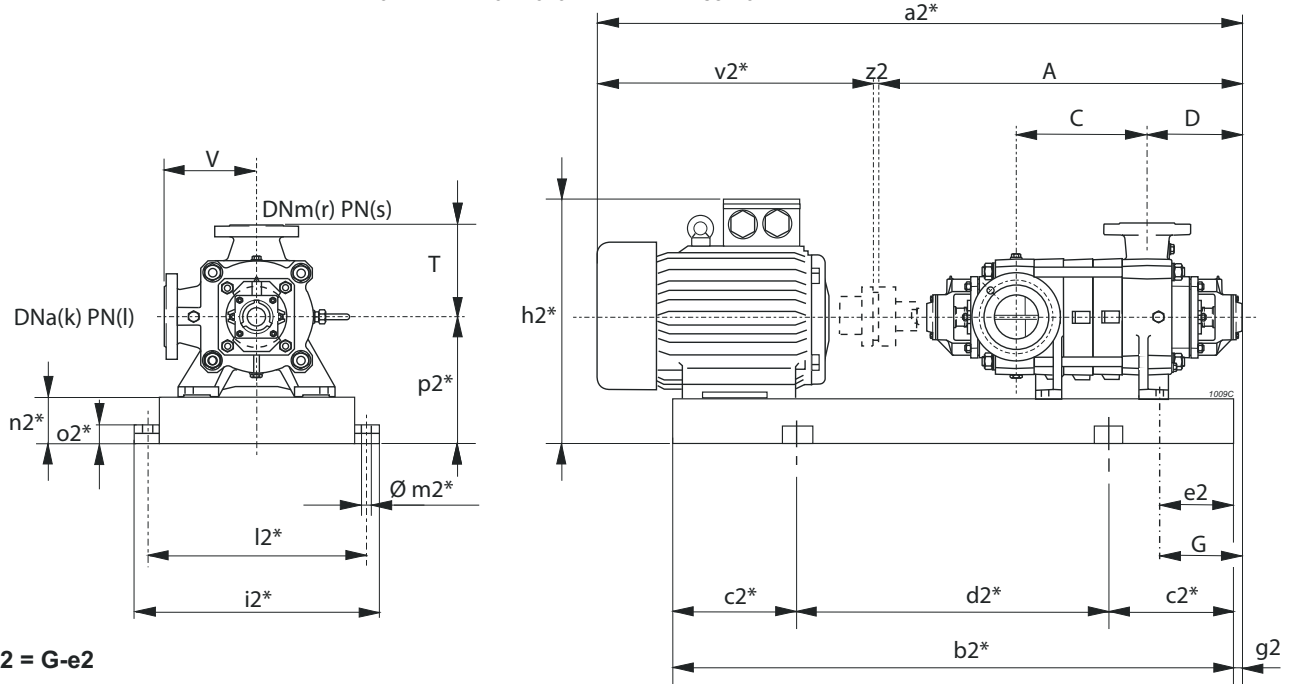

* Valori indicativi in funzione della marca di motore utilizzato - Indicatives values according to the type of motor installed - Приблизительные значения в зависимости от марки двигателя

Pump Насос Помпа		Motor Двигатель Motore			BGAM	A	C	D	G	T	V	a2*	b2*	c2*	d2*	e2	h2*	i2*	k	l	l2*	m2*	n2*	o2*	p2*	r	s	v2*	z2	Weight Вес Peso		
Series Серия Serie	Type Тип Tipo	[kW]	Size Размер Grand.	Type Тип Tipo	[mm]																											[kg]
PMXL(S/H)T	125/8	37	225S	819/HR	1633	845	337	294	320	320	2430	2054	350	1354	60	750	700	150	(1)	650	20	140	42	420	125	(2)	793	4	1137			
PMXL(S/H)T	/8	45	225M	872/HR	1633	845	337	294	320	320	2455	2079	350	1379	60	750	700	150	(1)	650	20	140	42	420	125	(2)	818	4	1180			
PMXL(S/H)T	/8	55	250M	818/IR	1633	845	337	294	320	320	2517	2121	350	1421	60	795	700	150	(1)	650	20	140	42	420	125	(2)	880	4	1303			
PMXL(S/H)T	/8	75 ○	280S	486/IR	1633	845	337	294	320	320	2650	2168	350	1468	60	815	700	150	(1)	650	20	140	42	420	125	(2)	1013	4	1445			
PMXL(S/H)T	/8	90 ○	280M	487/LR	1633	845	337	294	320	320	2701	2219	350	1519	60	815	700	150	(1)	650	20	140	42	420	125	(2)	1064	4	1514			
PMXL(S/H)T	125/9	37	225S	821/HR	1733	945	337	294	320	320	2530	2154	350	1454	60	750	700	150	(1)	650	20	140	42	420	125	(2)	793	4	1187			
PMXL(S/H)T	/9	45	225M	854/HR	1733	945	337	294	320	320	2555	2179	350	1479	60	750	700	150	(1)	650	20	140	42	420	125	(2)	818	4	1230			
PMXL(S/H)T	/9	55	250M	873/IR	1733	945	337	294	320	320	2617	2221	350	1521	60	795	700	150	(1)	650	20	140	42	420	125	(2)	880	4	1353			
PMXL(S/H)T	/9	75 ○	280S	490/IR	1733	945	337	294	320	320	2750	2268	400	1468	60	815	700	150	(1)	650	20	140	42	420	125	(2)	1013	4	1495			
PMXL(S/H)T	/9	90 ○	280M	491/LR	1733	945	337	294	320	320	2801	2319	400	1519	60	815	700	150	(1)	650	20	140	42	420	125	(2)	1064	4	1564			
PMXL(S/H)T	/9	110 ○	315S	492/LR	1733	945	337	294	320	320	2948	2425	400	1625	90	1030	780	150	(1)	730	22	160	50	475	125	(2)	1211	4	1899			
PMXL(S/H)T	125/10	45	225M	822/HR	1833	1045	337	294	320	320	2655	2279	400	1479	60	750	700	150	(1)	650	20	140	42	420	125	(2)	818	4	1280			
PMXL(S/H)T	/10	55	250M	874/IR	1833	1045	337	294	320	320	2717	2321	400	1521	60	795	700	150	(1)	650	20	140	42	420	125	(2)	880	4	1404			
PMXL(S/H)T	/10	75 ○	280S	494/IR	1833	1045	337	294	320	320	2850	2368	400	1568	60	815	700	150	(1)	650	20	140	42	420	125	(2)	1013	4	1545			
PMXL(S/H)T	/10	90 ○	280M	495/LR	1833	1045	337	294	320	320	2901	2419	400	1619	60	815	700	150	(1)	650	20	140	42	420	125	(2)	1064	4	1614			
PMXL(S/H)T	/10	110 ○	315S	496/LR	1833	1045	337	294	320	320	3048	2525	400	1725	90	1030	780	150	(1)	730	22	160	50	475	125	(2)	1211	4	1950			

BGAM = Base and coupling
 * = Indicatives values according to the type of motor installed.
 ○ Motor in IE4 efficiency class according to EU REGULATION 2019/1781. Available in other efficiency classes for non-EU markets.

BGAMA = Рама и муфта
 * = Приблизит. значения в зависимости от марки двигателя.
 ○ Двигатель класса эффективности IE4 в соответствии с РЕГЛАМЕНТОМ ЕС 2019/1781. Имеются варианты в других классах эффективности для рынков за пределами ЕС.

BGAM = Base giunto e coprigiunto
 * = Valori indicativi in funzione della marca di motore utilizzato.
 ○ Motore in classe di efficienza IE4 in conformità al REGOLAMENTO UE2019/1781. Disponibili in altre classi di efficienza per mercati extra UE.

(1) PMXL=25 bar PMXLST=25 bar PMXLHT=40 bar
 (2) PMXL=40 bar PMXLST=63 bar PMXLHT=100 bar

(1) PMXL=25 бар PMXLST=25 бар PMXLHT=40 бар
 (2) PMXL=40 бар PMXLST=63 бар PMXLHT=100 бар

(1) PMXL=25 бар PMXLST=25 бар PMXLHT=40 бар
 (2) PMXL=40 бар PMXLST=63 бар PMXLHT=100 бар

Utilization field <i>Область применения</i> Campo di utilizzo ≥ 60% η		
Stage number: compatibly with the maximum pressure. <i>Кол-во ступеней: совместимое с макс. давлением.</i> Numero stadi: compatibilmente con la pressione massima di esercizio.		
Type <i>Тип</i> Tipo	MIN.	MAX.
PMXT	2	10
PMXST	2	10
PMXHT	2	10
NB. For two-stage pumps only, reduce efficiency by one point. <i>Только для двухступенчатых насосов - снизить КПД на 1 единицу</i> Solamente per le pompe a due stadi, ridurre di un punto il rendimento.		

Wet moment of inertia J <i>Момент инерции J мокрый</i> Momento d'inerzia J bagnato $J = \frac{1}{2}PD^2$ - [kg m ²]		
Impeller type <i>Тип раб. колеса</i> Girante tipo	PMX(S/H)T125/1	For each additional stage <i>Для каждой доп. ступени</i> Per ogni stadio in più
Stainless steel <i>Нержав. сталь</i> Acciaio inox	0,1011	0,0880

Maximum permissible power <i>Макс. допустимая мощность</i> Massime potenze ammissibili	
Type <i>Тип</i> Tipo	N/n MAX.
PMXT	0,25
PMXST	0,25
PMXHT	0,25
For seal limits and calculation formulas of the maximum permissible powers, see technical data section. <i>Ограничения по уплотнениям и формулы расчета макс. допустимой мощности - см. раздел "Технические данные".</i> Per i limiti tenute e le formule di calcolo delle massime potenze ammissibili, vedere sezione dati tecnici.	

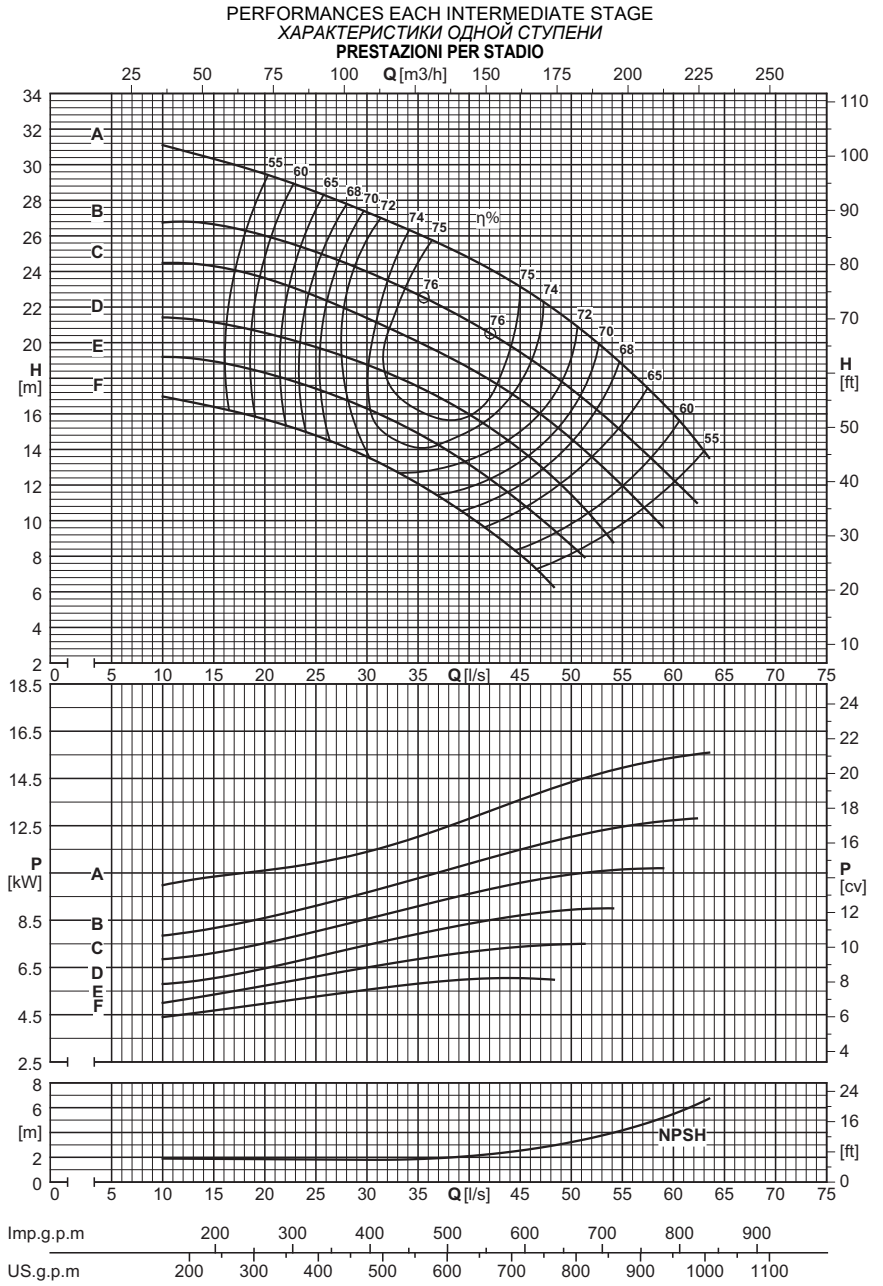

Dna x DNm	Impeller type <i>Тип раб. кол.</i> Girante tipo	Capacity - <i>Расход - Portata</i>																						
		[l/s]	0	20	22	24	26	28	30	32	34	36	38	40	42	44	46	48	50	52	54	56	58	60
		[m3/h]	0	72	79,2	86,4	93,6	100,8	108	115,2	122,4	129,6	136,8	144	151,2	158,4	165,6	172,8	180	187,2	194,4	201,6	208,8	216
		[l/min]	0	1200	1320	1440	1560	1680	1800	1920	2040	2160	2280	2400	2520	2640	2760	2880	3000	3120	3240	3360	3480	3600

		PMX(S/H)T125/1																							
150x125	F	[m]	18	15,5	15,5	15,5	14,5	14	13,5	13,5	12,5	11,5	11	10	9,4	8,5									
150x125	F	[kW]		5	5,1	5,2	5,3	5,4	5,5	5,6	5,7	5,8	5,9	6	6	6									
150x125	E	[m]	20	20	18,5	17	17	16,5	16	15,5	15	14,5	14	13	12,5	11,5	10,5	9,9	8,9						
150x125	E	[kW]		5,6	5,7	6,2	6,3	6,4	6,6	6,7	6,8	6,9	7	7,1	7,2	7,2	7,3	7,6	7,6						
150x125	D	[m]	22	20	20	20	19,5	19,5	19	18	17,5	17	16,5	16,5	15	14,5	13,5	13	11,5	10,5					
150x125	D	[kW]		6,6	6,7	6,9	7	7,2	7,3	7,8	7,9	8,1	8,2	8,3	8,4	8,5	8,6	9	9	9					
150x125	C	[m]	25	24	24,5	22	22	22	21,5	21,5	20	19,5	19,5	18,5	18	17	16,5	15,5	14,5	14	12,5	11			
150x125	C	[kW]		7,4	7,5	8,2	8,2	8,3	8,4	8,6	9,1	9,2	9,4	9,5	10	10,1	10,1	10,2	10,2	10,7	10,6	10,6			
150x125	B	[m]	28	27	24,5	25	25,5	25,5	23,5	23,5	23,5	22	21,5	21,5	20,5	19,5	19	18	17	16,5	15,5	14,5	14	12,5	
150x125	B	[kW]		8,3	9,1	9,1	9,1	9,2	9,8	9,9	10	10,6	10,7	10,8	11	11,5	11,6	11,7	11,8	12,3	12,4	12,4	12,8	12,8	
150x125	A	[m]	32,5	31	28,5	29	30	27	27	27	27	25,5	25,5	25	24	23,5	23	22	21	20	19	18,5	17	15,5	
150x125	A	[kW]		10	11	10,8	10,7	11,5	11,5	11,5	11,6	12,3	12,5	12,6	13,3	13,5	13,7	14,3	14,4	14,6	14,7	15	15,5	15,5	
		NPSH																							
		[m]		1,8	1,8	1,8	1,8	1,8	1,8	1,8	1,8	1,8	1,9	2	2,1	2,3	2,4	2,7	2,9	3,2	3,5	4	4,5	4,9	5,4

Utilization field Область применения Campo di utilizzo ≥ 60% η		
Stage number: compatibly with the maximum pressure. Кол-во ступеней: совместимое с макс. давлением. Numero stadi: compatibilmente con la pressione massima di esercizio.		
Type Тип Tipo	MIN.	MAX.
PMXT	2	10
PMXST	2	10
PMXHT	2	10
NB. For two-stage pumps only, reduce efficiency by one point. Только для двухступенчатых насосов - снизить КПД на 1 единицу Solamente per le pompe a due stadi, ridurre di un punto il rendimento.		

Wet moment of inertia J Момент инерции J мокрый Momento d'inerzia J bagnato $J = \frac{1}{4}PD^2$ - [kg m ²]		
Impeller type Тип раб. колеса Girante tipo	PMX(S/H)T125/1	For each additional stage Для каждой доп. ступени Per ogni stadio in più
Stainless steel Нержавеющая сталь Acciaio inox	0,1011	0,0880

Maximum permissible power Макс. допустимая мощность Massime potenze ammissibili	
Type Тип Tipo	N/n MAX.
PMXT	0,25
PMXST	0,25
PMXHT	0,25
For seal limits and calculation formulas of the maximum permissible powers, see technical data section. Ограничения по уплотнениям и формулы расчета макс. допустимой мощности - см. раздел "Технические данные". Per i limiti tenute e le formule di calcolo delle massime potenze ammissibili, vedere sezione dati tecnici.	

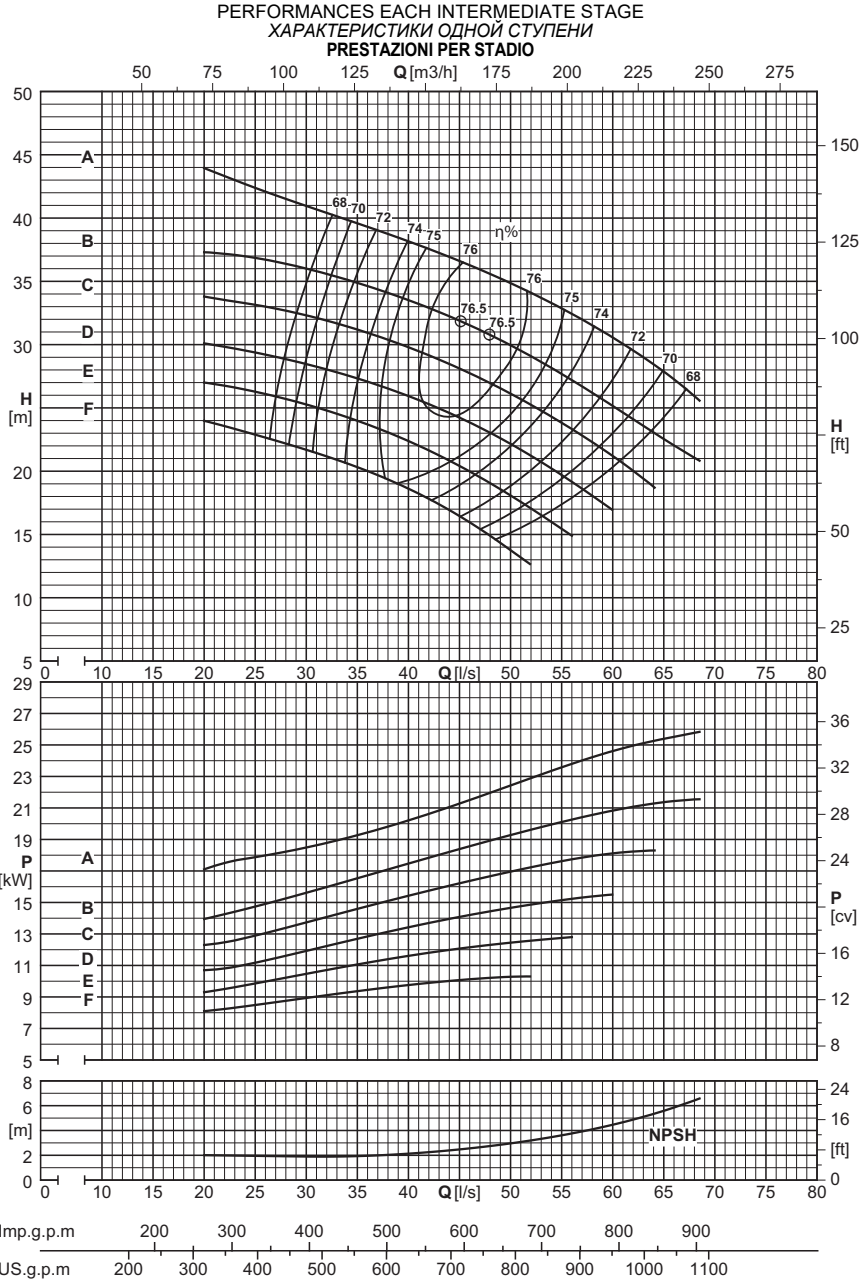

Dna x Dnm	Impeller type Тип раб. кол. Girante tipo	Capacity - Расход - Portata																						
		[l/s]	0	28	30	32	34	36	38	40	42	44	46	48	50	52	54	56	58	60	62	64	66	68
		[m ³ /h]	0	100,8	108	115,2	122,4	129,6	136,8	144	151,2	158,4	165,6	172,8	180	187,2	194,4	201,6	208,8	216	223,2	230,4	237,6	244,8
		[l/min]	0	1680	1800	1920	2040	2160	2280	2400	2520	2640	2760	2880	3000	3120	3240	3360	3480	3600	3720	3840	3960	4080

		PMX(S/H)T125/1																						
150x125	F	[m]	25,5	22,5	21,5	21	20,5	20	19,5	18,5	18	17,5	16	15	13,5	12,5								
150x125	F	[kW]		8,7	8,9	9,2	9,4	9,3	9,5	9,7	9,9	10,1	10,3	10,1	10,2	10,3								
150x125	E	[m]	29	25,5	25	24,5	24	23,5	23	22,5	21,5	21	20	20	19	17,5	16,5	15						
150x125	E	[kW]		10,3	10,6	10,8	11,1	11,3	11,6	11,5	11,7	11,9	12,1	12,2	12,4	12,5	12,7	12,8						
150x125	D	[m]	32	29	29	28,5	29	27,5	27	26,5	25,5	24,5	23,5	23,5	22	21	20,5	19	18	17				
150x125	D	[kW]		11,5	11,8	12,1	12,4	12,7	13	13,2	13,9	14,1	14,3	14,6	14,8	14,9	15	15,5	15,5	15,5				
150x125	C	[m]	36,5	31,5	31,5	31,5	31,5	31	30,5	30	28,5	28	27,5	27	26	25,5	24,5	23	22,5	21,5	20	18,5	18	
150x125	C	[kW]		13,7	13,9	14,2	14,4	14,7	15	15	16,5	16	16,5	16,5	17	17	17,5	18	18	18,5	18,5	19		
150x125	B	[m]	41	36,5	36	36,5	34	34	34,5	33,5	33,5	32	31,5	31	30	29	28	27	26	25	24,5	23	22	21
150x125	B	[kW]		15,5	15,5	15,5	16,5	17	17	17,5	17,5	18,5	18,5	19	19	19,5	20	20,5	20,5	20,5	21,5	21,5	21,5	21,5
150x125	A	[m]	47,5	41	41	41	38,5	38,5	38,5	38,5	38	36,5	36	35,5	35	34,5	33	32,5	31,5	30,5	29,5	28,5	27,5	26
150x125	A	[kW]		18,5	18,5	18,5	19,5	19,5	20	20	20,5	21,5	21,5	22	22,5	22,5	23,5	24	24	24,5	25	25,5	25,5	25,5

		NPSH																					
	[m]		1,9	1,9	1,9	1,9	2	2	2,1	2,3	2,4	2,5	2,8	3	3,2	3,5	3,8	4,1	4,5	4,8	5,4	5,8	6,5

Utilization field Область применения Campo di utilizzo ≥ 60% η		
Stage number: compatibly with the maximum pressure. Кол-во ступеней: совместимое с макс. давлением. Numero stadi: compatibilmente con la pressione massima di esercizio.		
Type Тип Tipo	MIN.	MAX.
PMXT	2	10
PMXST	2	10
PMXHT	2	10
NB. For two-stage pumps only, reduce efficiency by one point. Только для двухступенчатых насосов - снизить КПД на 1 единицу Solamente per le pompe a due stadi, ridurre di un punto il rendimento.		

Wet moment of inertia J Момент инерции J мокрый Momento d'inerzia J bagnato J=1/4PD ² - [kg m ²]		
Impeller type Тип раб. колеса Girante tipo	PMX(S/H)T125/1	For each additional stage Для каждой доп. ступени Per ogni stadio in più
Stainless steel Нержавеющая сталь Acciaio inox	0,1011	0,0880

Maximum permissible power Макс. допустимая мощность Massime potenze ammissibili	
Type Тип Tipo	N/n MAX.
PMXT	0,25
PMXST	0,25
PMXHT	0,25
For seal limits and calculation formulas of the maximum permissible powers, see technical data section. Ограничения по уплотнениям и формулы расчета макс. допустимой мощности - см. раздел "Технические данные". Per i limiti tenute e le formule di calcolo delle massime potenze ammissibili, vedere sezione dati tecnici.	

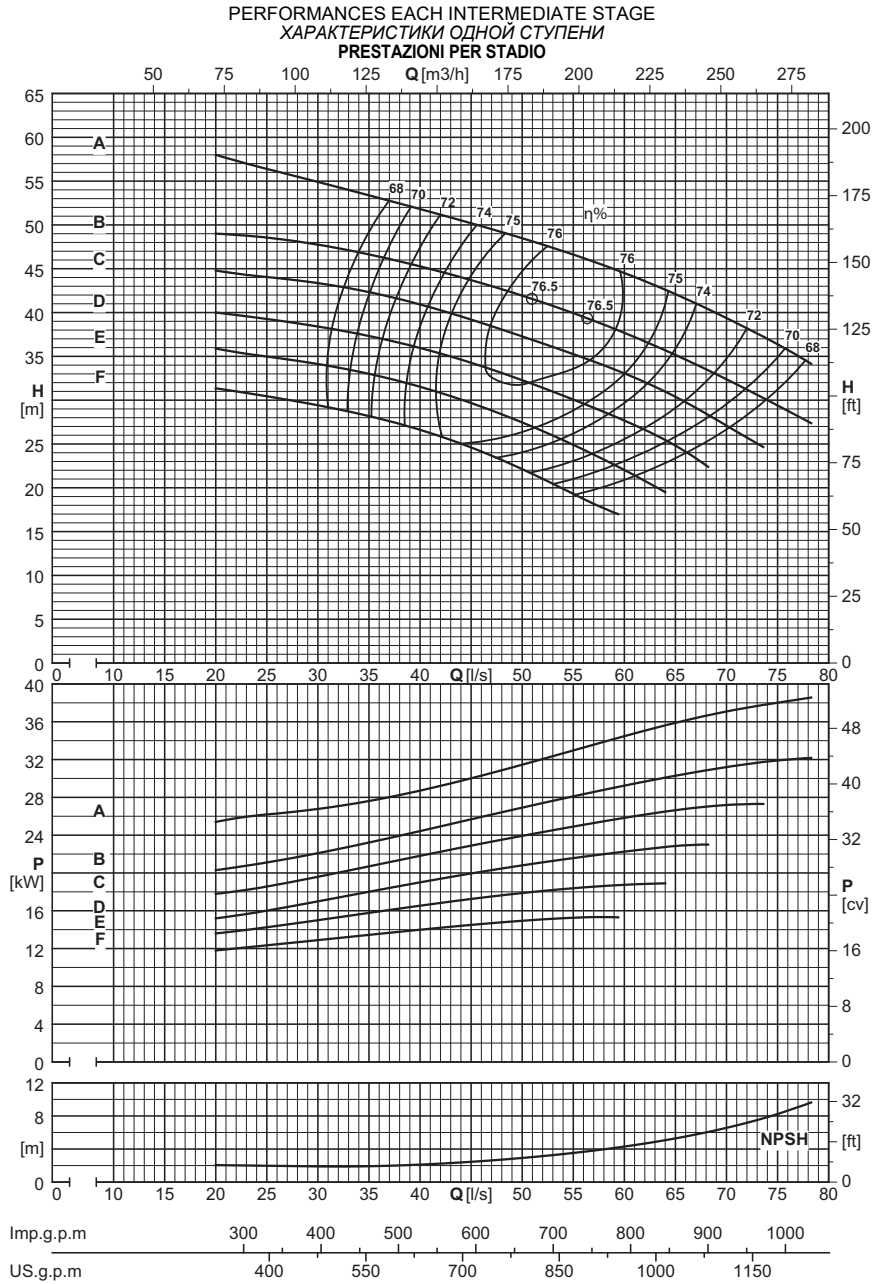

Dna x DNm	Impeller type Тип раб. кол. / Girante tipo	Capacity - Расход - Portata																
		[l/s]	0	22	26	30	34	38	42	46	50	54	58	62	66	70	74	78
		[m ³ /h]	0	79,2	93,6	108	122,4	136,8	151,2	165,6	180	194,4	208,8	223,2	237,6	252	266,4	280,8
		[l/min]	0	1320	1560	1800	2040	2280	2520	2760	3000	3240	3480	3720	3960	4200	4440	4680

		PMX(S/H)T125/1																			
150x125	F	[m]	33,5	30,5	29,5	28,5	27,5	26,5	24	22	20	18	16,5								
150x125	F	[kW]		12,4	12,8	13,2	13,6	14	14,4	15	15,5	15,5	16,5								
150x125	E	[m]	37,5	36	33,5	33	32,5	30,5	29	27,5	25,5	23,5	21	19							
150x125	E	[kW]		14	15,5	15,5	16	17	17,5	18	18	19	19	19,5							
150x125	D	[m]	42		38,5	38,5	36,5	35,5	33,5	32,5	30,5	28,5	26,5	24	22						
150x125	D	[kW]			17	17,5	18,5	19	20,5	20,5	21,5	22	22	23,5	23,5						
150x125	C	[m]	47,5		45,5	42,5	40,5	40,5	38,5	37,5	35,5	34	32	30	27	24,5					
150x125	C	[kW]			19	20,5	21,5	22	23,5	23,5	25	26	26	27,5	27	27,5					
150x125	B	[m]	53		46,5	48,5	46	44,5	42,5	42	40,5	38,5	37	34,5	32,5	29,5	27,5				
150x125	B	[kW]			22,5	22,5	24	25	26,5	26,5	28	29	29,5	30,5	31,5	31,5	32				
150x125	A	[m]	62			55	52	50	48,5	49	47	45	44	41,5	39,5	37	34,5				
150x125	A	[kW]				26,5	29	29,5	31	31	32,5	34	35	36	37,5	37,5	38,5				

		NPSH																		
	[m]	2	2	1,9	1,9	2	2,2	2,5	2,9	3,4	4	4,6	5,5	6,7	7,8	9,6				

Utilization field Область применения Campo di utilizzo ≥ 60% η		
Stage number: compatibly with the maximum pressure. Кол-во ступеней: совместимое с макс. давлением. Numero stadi: compatibilmente con la pressione massima di esercizio.		
Type Тип Tipo	MIN.	MAX.
PMXT	2	8
PMXST	2	8
PMXHT	2	10
NB. For two-stage pumps only, reduce efficiency by one point. Только для двухступенчатых насосов - снизить КПД на 1 единицу Solamente per le pompe a due stadi, ridurre di un punto il rendimento.		

Wet moment of inertia J Момент инерции J мокрый Momento d'inerzia J bagnato J=1/4 PD ² - [kg m ²]		
Impeller type Тип раб. колеса Girante tipo	PMX(S/H)T125/1	For each additional stage Для каждой доп. ступени Per ogni stadio in più
Stainless steel Нержав. сталь Acciaio inox	0,1011	0,0880

Maximum permissible power Макс. допустимая мощность Massime potenze ammissibili	
Type Тип Tipo	N/h MAX.
PMXT	0,25
PMXST	0,25
PMXHT	0,25
For seal limits and calculation formulas of the maximum permissible powers, see technical data section. Ограничения по уплотнениям и формулы расчета макс. допустимой мощности - см. раздел "Технические данные". Per i limiti tenute e le formule di calcolo delle massime potenze ammissibili, vedere sezione dati tecnici.	

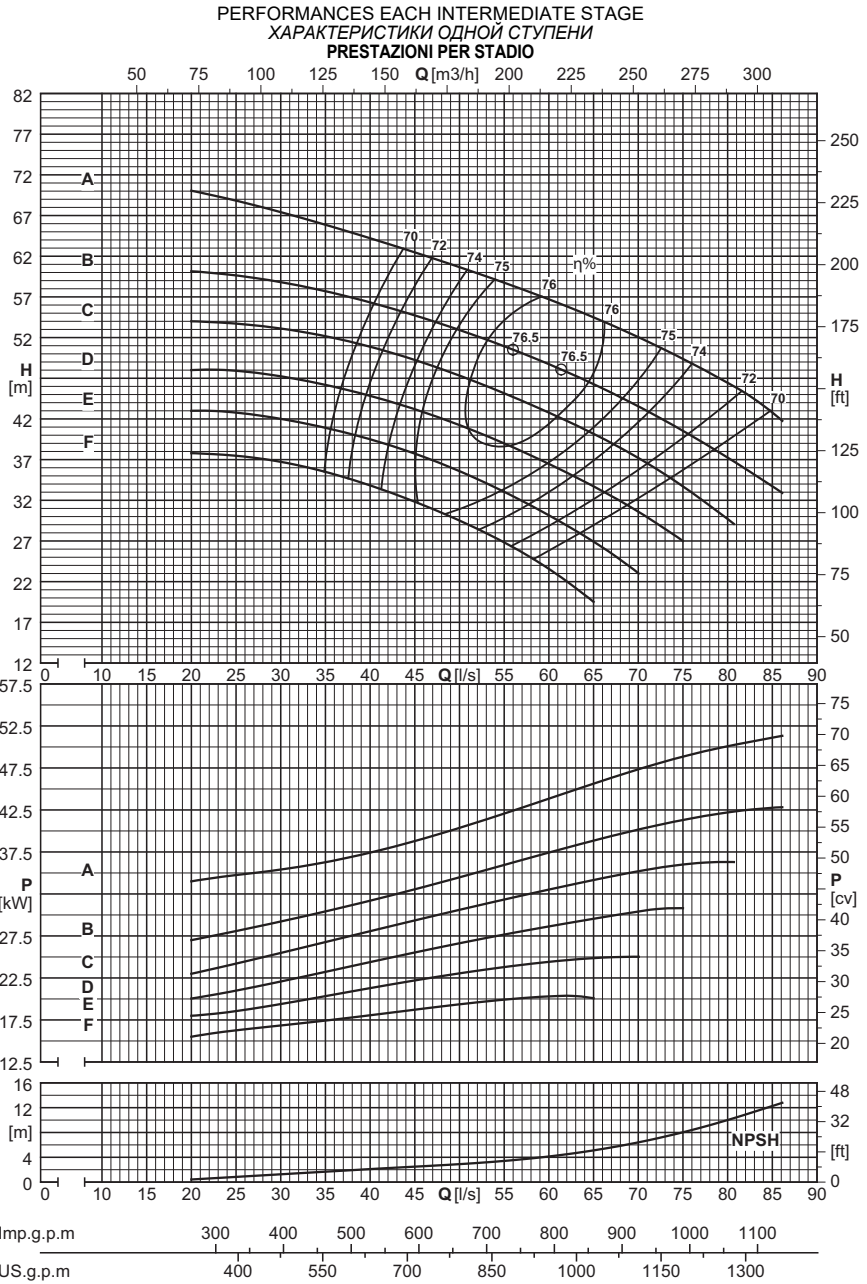

Capacity - Расход - Portata

Dna x Dnm	Impeller type Тип раб. кол. Girante tipo	Capacity - Расход - Portata																	
		[l/s]	0	26	30	34	38	42	46	50	54	58	62	66	70	74	78	82	86
		[m ³ /h]	0	93,6	108	122,4	136,8	151,2	165,6	180	194,4	208,8	223,2	237,6	252	266,4	280,8	295,2	309,6
		[l/min]	0	1560	1800	2040	2280	2520	2760	3000	3240	3480	3720	3960	4200	4440	4680	4920	5160

PMX(S/H)T125/1

150x125	F	[m]	40	36	36	35	33	31,5	29,5	27,5	25,5	21,5							
150x125	F	[kW]		17	17	17,5	18,5	19	19	20	20	20							
150x125	E	[m]	45,5	42,5	40,5	40,5	38,5	37,5	35,5	33,5	31,5	29	26,5	23,5	22				
150x125	E	[kW]		19	20,5	21	22	22,5	23,5	23,5	24,5	24,5	25,5	25,5	26,5				
150x125	D	[m]	50		47,5	45	45,5	43	41	39,5	37,5	35,5	33	31	27,5	26,5			
150x125	D	[kW]			23	24	24,5	25,5	27,5	27	28,5	28,5	29,5	30,5	30,5	32			
150x125	C	[m]	57		50	52	50	48,5	46,5	46,5	44	41,5	39,5	37	34,5	31,5	28,5		
150x125	C	[kW]			27	27,5	28,5	30	31	31	32,5	33,5	35	35	36	36,5	37		
150x125	B	[m]	64		57	56	54	53	53	51	50	47,5	45,5	43,5	41	38,5	35,5	33,5	
150x125	B	[kW]			30	31,5	33	34	34,5	35,5	36,5	38	39,5	40,5	40,5	41,5	42	43	
150x125	A	[m]	75			64	62	60	61	59	57	55	53	51	50	47,5	45	42	
150x125	A	[kW]				37,5	38,5	40	40	41,5	43,5	44,5	46	48	48	49	50	51,5	

NPSH

[m]	0,9	1,2	1,6	1,9	2,3	2,6	2,9	3,3	3,8	4,5	5,4	6,4	7,8	9	11,1	12,8
-----	-----	-----	-----	-----	-----	-----	-----	-----	-----	-----	-----	-----	-----	---	------	------

Utilization field Область применения Campo di utilizzo ≥ 60% η		
Stage number: compatibly with the maximum pressure. Кол-во ступеней: совместимое с макс. давлением. Numero stadi: compatibilmente con la pressione massima di esercizio.		
Type Тип Tipo	MIN.	MAX.
PMXT	2	5
PMXST	2	5
PMXHT	2	8
NB. For two-stage pumps only, reduce efficiency by one point. Только для двухступенчатых насосов - снизить КПД на 1 единицу Solamente per le pompe a due stadi, ridurre di un punto il rendimento.		

Wet moment of inertia J Момент инерции J мокрый Momento d'inerzia J bagnato J=¼PD ² - [kg m ²]		
Impeller type Тип раб. колеса Girante tipo	PMX(S/H)T125/1	For each additional stage Для каждой доп. ступени Per ogni stadio in più
Stainless steel Нержав. сталь Acciaio inox	0,1011	0,0880

Maximum permissible power Макс. допустимая мощность Massime potenze ammissibili	
Type Тип Tipo	N/n MAX.
PMXT	0,25
PMXST	0,25
PMXHT	0,25
For seal limits and calculation formulas of the maximum permissible powers, see technical data section. Ограничения по уплотнениям и формулы расчета макс. допустимой мощности - см. раздел "Технические данные". Per i limiti tenute e le formule di calcolo delle massime potenze ammissibili, vedere sezione dati tecnici.	

PERFORMANCES EACH INTERMEDIATE STAGE
ХАРАКТЕРИСТИКИ ОДНОЙ СТУПЕНИ
PRESTAZIONI PER STADIO

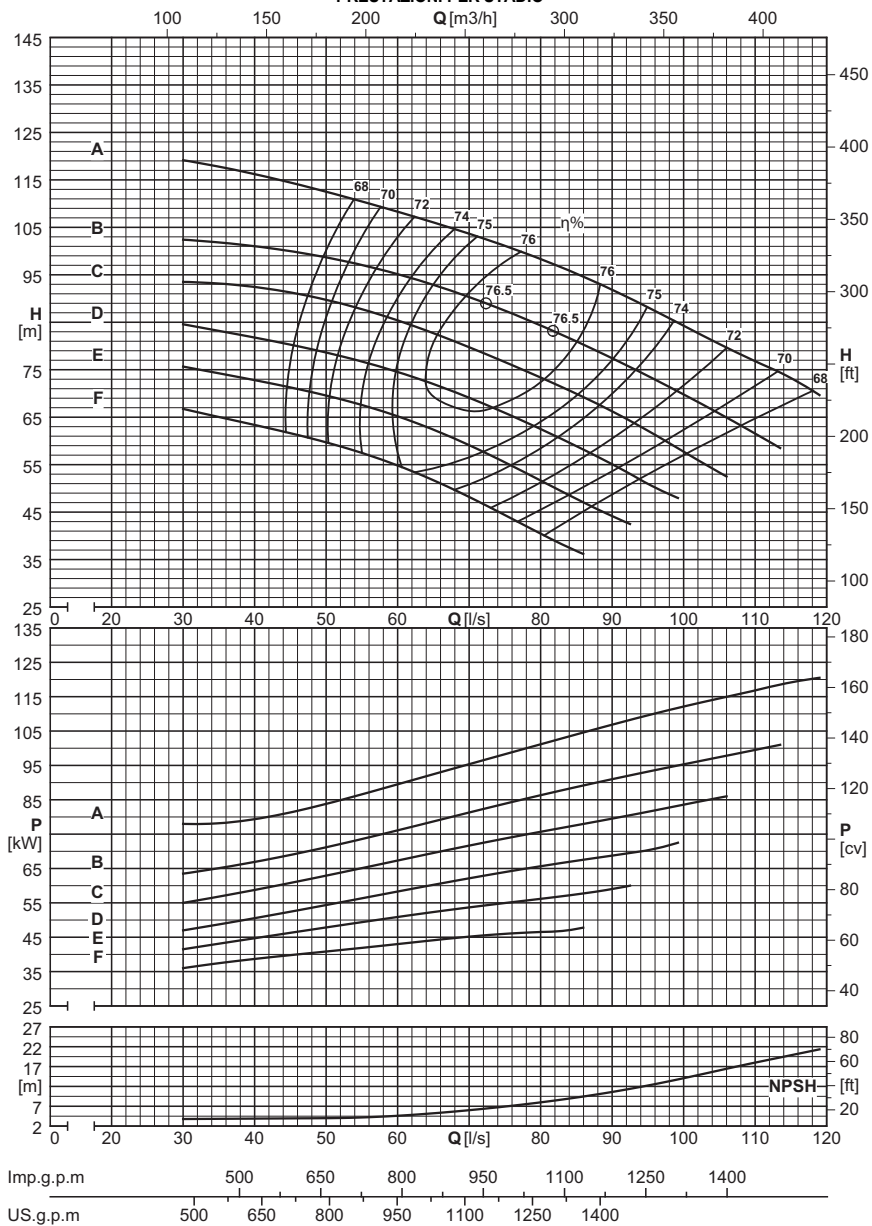

Dna x DNm	Impeller type Тип раб. кол. Girante tipo	Capacity - Расход - Portata																				
		[l/s]	0	40	44	48	52	56	60	64	68	72	76	80	84	88	92	96	100	104	108	112
		[m ³ /h]	0	144	158,4	172,8	187,2	201,6	216	230,4	244,8	259,2	273,6	288	302,4	316,8	331,2	345,6	360	374,4	388,8	403,2
		[l/min]	0	2400	2640	2880	3120	3360	3600	3840	4080	4320	4560	4800	5040	5280	5520	5760	6000	6240	6480	6720

		PMX(S/H)T125/1																						
150x125	F	[m]	69	61	62	60	57	57	54	52	49,5	47	43,5	40,5	37,5	35,5								
150x125	F	[kW]		39,5	39	40,5	42	42	43,5	43,5	44,5	46	45,5	46,5	47,5	49								
150x125	E	[m]	79	72	70	68	69	67	65	62	60	57	54	51	49	45,5	42,5	41						
150x125	E	[kW]		45	46,5	48,5	48	49,5	51	52,5	52,5	54	55	56,5	58	58	59,5	62,5						
150x125	D	[m]	88	83	81	79	77	75	73	71	69	68	65	62	59	56	53	50	47,5					
150x125	D	[kW]		49,5	51,5	53,5	55	57,5	59	60,5	62	62	63,5	65	66,5	69	69,5	71	73					
150x125	C	[m]	100		87	87	86	85	83	81	79	77	75	72	70	67	64	61	58	54	51			
150x125	C	[kW]			62,5	64	65,5	67	68,5	70,5	72	73,5	75	76	78	79	81	82	84	86	87			
150x125	B	[m]	112		98	98	98	97	96	94	92	90	85	83	81	78	75	72	69	66	62	59		
150x125	B	[kW]			69,5	70,5	72	74	75	77	79	81	85	87	89	90	92	93	95	96	98	99		
150x125	A	[m]	130			114	114	113	105	105	104	102	101	99	96	92	90	87	84	81	78	75		
150x125	A	[kW]				81	83	85	91	92	94	96	98	100	102	106	108	110	112	113	114	116		

		NPSH																						
		[m]		3,9	3,9	4	4	4,2	4,6	5	5,7	6,4	7,1	8	9	10,1	11,2	12,6	14,1	15,8	17,5	19		

Overall dimensions and weights
 Общие габариты и вес
 Dimensioni di ingombro e pesi

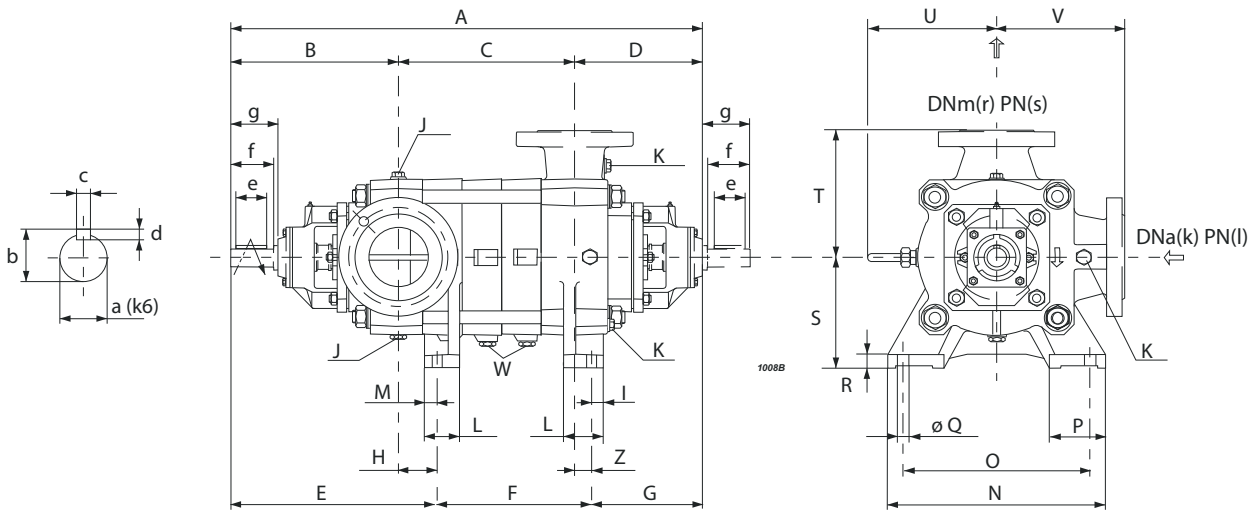

Series Серия Serie	Type Тип Tipo	A	B	C	D	E	F	G	H	S	T	U	V	Z	Weight Вес Peso
		[mm]													
PMX(S/H)T	125/2	1033	451	245	337	539	200	294	88	280	320	326	320	43	462
PMX(S/H)T	125/3	1133	451	345	337	539	300	294	88	280	320	326	320	43	514
PMX(S/H)T	125/4	1233	451	445	337	539	400	294	88	280	320	326	320	43	565
PMX(S/H)T	125/5	1333	451	545	337	539	500	294	88	280	320	326	320	43	616
PMX(S/H)T	125/6	1433	451	645	337	539	600	294	88	280	320	326	320	43	667
PMX(S/H)T	125/7	1533	451	745	337	539	700	294	88	280	320	326	320	43	718
PMX(S/H)T	125/8	1633	451	845	337	539	800	294	88	280	320	326	320	43	770
PMX(S/H)T	125/9	1733	451	945	337	539	900	294	88	280	320	326	320	43	821
PMX(S/H)T	125/10	1833	451	1045	337	539	1000	294	88	280	320	326	320	43	872

Foot dimensions Размеры ножек Dimensioni dei piedi							
I	L	M	N	O	P	Q	R
[mm]							
30	100	29,5	570	460	145	24	35

Shaft projection Выступ вала Sporgenza d'albero							
a	b	c	d	e	f	g	
[mm]							
45	48,5	14	9	100	110	125	

Flanges Фланцы Flange				
Type Тип Tipo	(k) DNa	(l) PN	(r) DNm	(s) PN
	[mm]	[bar]	[mm]	[bar]
PMXT	150	25	125	40
PMXST	150	25	125	63
PMXHT	150	40	125	100

Plugs Пробки Tappi		
J	K	W
G3/4	G1/2	G1/4

Selection - dimensions and weights for base mounted electric pumps
 Подбор - забариты и вес электронасосов на раме
 Selezione - dimensioni e pesi elettropompe su base

COUPLINGS WITH STANDARDIZED ENCLOSED ELECTRIC MOTORS
 СОЕДИНЕНИЕ С НОРМАЛИЗОВАННЫМИ ЗАКРЫТЫМИ ЭЛЕКТРОДВИГАТЕЛЯМИ
 ACCOPPIAMENTI CON MOTORI ELETTRICI CHIUSI NORMALIZZATI

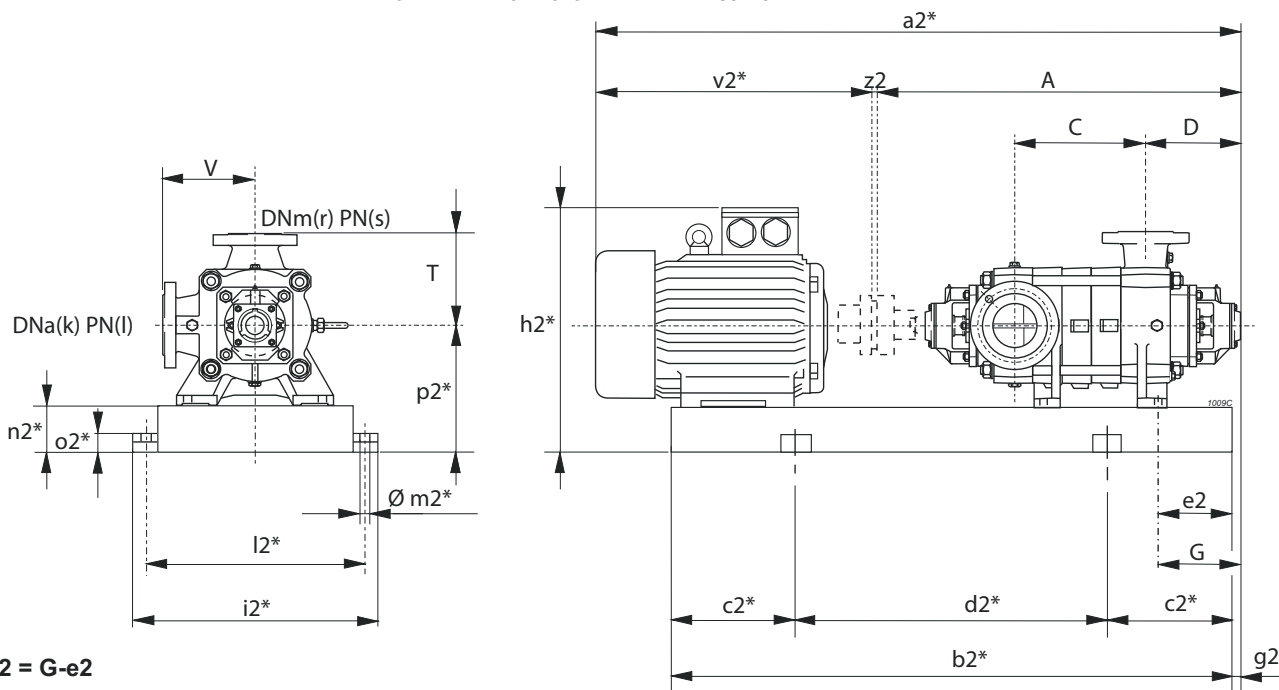

* Valori indicativi in funzione della marca di motore utilizzato - Indicatives values according to the type of motor installed - Приблизительные значения в зависимости от марки двигателя

Pump Насос Pompa		Motor Двигатель Motore		BGAM	A	C	D	G	T	V	a2*	b2*	c2*	d2*	e2	h2*	i2*	k	l	l2*	m2*	n2*	o2*	p2*	r	s	v2*	z2	Weight Вес Peso	
Series Серия Serie	Type Тип Tipo	[kW]	Size Размер Grand.	Type Тип Tipo	[mm]																									[kg]
PMX(S/H)T	125/2	110	315S	800/IR	1033	245	337	294	320	320	2218	1695	300	1095	90	1030	780	150	(1)	730	22	160	50	475	125	(2)	1181	4	1543	
PMX(S/H)T	/2	132	315M	335/IR	1033	245	337	294	320	320	2328	1805	300	1205	90	1030	780	150	(1)	730	22	160	50	475	125	(2)	1291	4	1619	
PMX(S/H)T	/2	160	315L	335/IR	1033	245	337	294	320	320	2328	1805	300	1205	90	1030	780	150	(1)	730	22	160	50	475	125	(2)	1291	4	1697	
PMX(S/H)T	/2	200	315L	336/IE4/LR	1033	245	337	294	320	320	2418	1895	300	1295	198	1030	780	150	(1)	730	22	160	50	475	125	(2)	1381	4	1831	
PMX(S/H)T	/2	250	355M	337/LR	1033	245	337	294	320	320	2563	1879	300	1279	110	1136	880	150	(1)	830	22	180	50	535	125	(2)	1526	4	2244	
PMX(S/H)T	/2	280	355M	4003/MR	1033	245	337	294	320	320	2563	1879	300	1279	110	1136	880	150	(1)	830	22	180	50	535	125	(2)	1526	4	2373	
PMX(S/H)T	125/3	160	315L	338/LR	1133	345	337	294	320	320	2428	1905	300	1305	90	1030	780	150	(1)	730	22	160	50	475	125	(2)	1291	4	1753	
PMX(S/H)T	/3	200	315L	338/IE4/LR	1133	345	337	294	320	320	2518	1995	350	1295	198	1030	780	150	(1)	730	22	160	50	475	125	(2)	1381	4	1882	
PMX(S/H)T	/3	250	355L	339/LR	1133	345	337	294	320	320	2663	2049	350	1349	110	1136	880	150	(1)	830	22	180	50	535	125	(2)	1526	4	2298	
PMX(S/H)T	/3	280	355L	339/LR	1133	345	337	294	320	320	2663	2049	350	1349	110	1136	880	150	(1)	830	22	180	50	535	125	(2)	1526	4	2423	
PMX(S/H)T	/3	315	355L	339/MR	1133	345	337	294	320	320	2663	2049	350	1349	110	1136	880	150	(1)	830	22	180	50	535	125	(2)	1526	4	2427	
PMX(S/H)T	/3	355	355L	339/MR	1133	345	337	294	320	320	2663	2049	350	1349	110	1136	880	150	(1)	830	22	180	50	535	125	(2)	1526	4	2417	
PMX(S/H)T	125/4	200	315L	806/IE4/LR	1233	445	337	294	320	320	2618	2095	350	1395	198	1030	780	150	(1)	730	22	160	50	475	125	(2)	1381	4	1933	
PMX(S/H)T	/4	250	355M	340/LR	1233	445	337	294	320	320	2763	2079	350	1379	110	1136	880	150	(1)	830	22	180	50	535	125	(2)	1526	4	2349	
PMX(S/H)T	/4	280	355L	340/MR	1233	445	337	294	320	320	2763	2149	350	1449	110	1136	880	150	(1)	830	22	180	50	535	125	(2)	1526	4	2478	
PMX(S/H)T	/4	315	355L	340/MR	1233	445	337	294	320	320	2763	2149	350	1449	110	1136	880	150	(1)	830	22	180	50	535	125	(2)	1526	4	2478	
PMX(S/H)T	/4	355	355L	340/MR	1233	445	337	294	320	320	2763	2149	350	1449	110	1136	880	150	(1)	830	22	180	50	535	125	(2)	1526	4	2468	
PMX(S/H)T	125/5	280	355L	341/MR	1333	545	337	294	320	320	2863	2249	350	1549	110	1136	880	150	(1)	830	22	180	50	535	125	(2)	1526	4	2530	
PMX(S/H)T	/5	315	355L	341/MR	1333	545	337	294	320	320	2863	2249	350	1549	110	1136	880	150	(1)	830	22	180	50	535	125	(2)	1526	4	2530	
PMX(S/H)T	/5	355	355L	341/MR	1333	545	337	294	320	320	2863	2249	350	1549	110	1136	880	150	(1)	830	22	180	50	535	125	(2)	1526	4	2520	
PMX(H)T	125/6	315	355L	4000/MR	1433	645	337	294	320	320	2963	2349	400	1549	110	1136	880	150	(1)	830	22	180	50	535	125	(2)	1526	4	2581	
PMX(H)T	/6	355	355L	4000/MR	1433	645	337	294	320	320	2963	2349	400	1549	110	1136	880	150	(1)	830	22	180	50	535	125	(2)	1526	4	2571	
PMX(H)T	125/7	355	355L	4001/MR	1533	745	337	294	320	320	3063	2449	400	1649	110	1136	880	150	(1)	830	22	180	50	535	125	(2)	1526	4	2623	

Contact the sales network for couplings exceeding 355 kW.

В случае муфт мощностью более 355 кВт обратиться в нашу коммерческую сеть.

Per accoppiamenti superiori ai 355 kW, contattare la rete di vendita.

BGAM = Base and coupling

BGAMA = Рама и муфта

BGAM = Base giunto e coprigiunto

* = Indicatives values according to the type of motor installed.

* = Приблизит. значения в зависимости от марки двигателя.

* = Valori indicativi in funzione della marca di motore utilizzato.

○ Motor in IE4 efficiency class according to EU REGULATION 2019/1781. Available in other efficiency classes for non-EU markets.

○ Двигатель класса эффективности IE4 в соответствии с РЕГЛАМЕНТОМ ЕС 2019/1781. Имеются варианты в других классах эффективности для рынков за пределами ЕС.

○ Motore in classe di efficienza IE4 in conformità al REGOLAMENTO UE2019/1781. Disponibili in altre classi di efficienza per mercati extra UE.

(1) PMXT=25 bar PMXST=25 bar PMXHT=40 bar
 (2) PMXT=40 bar PMXST=63 bar PMXHT=100 bar

(1) PMXT=25 бар PMXST=25 бар PMXHT=40 бар
 (2) PMXT=40 бар PMXST=63 бар PMXHT=100 бар

(1) PMXT=25 bar PMXST=25 bar PMXHT=40 bar
 (2) PMXT=40 bar PMXST=63 bar PMXHT=100 bar

COUPLINGS WITH STANDARDIZED ENCLOSED ELECTRIC MOTORS
 СОЕДИНЕНИЕ С НОРМАЛИЗОВАННЫМИ ЗАКРЫТЫМИ ЭЛЕКТРОДВИГАТЕЛЯМИ
 ACCOPPIAMENTI CON MOTORI ELETTRICI CHIUSI NORMALIZZATI

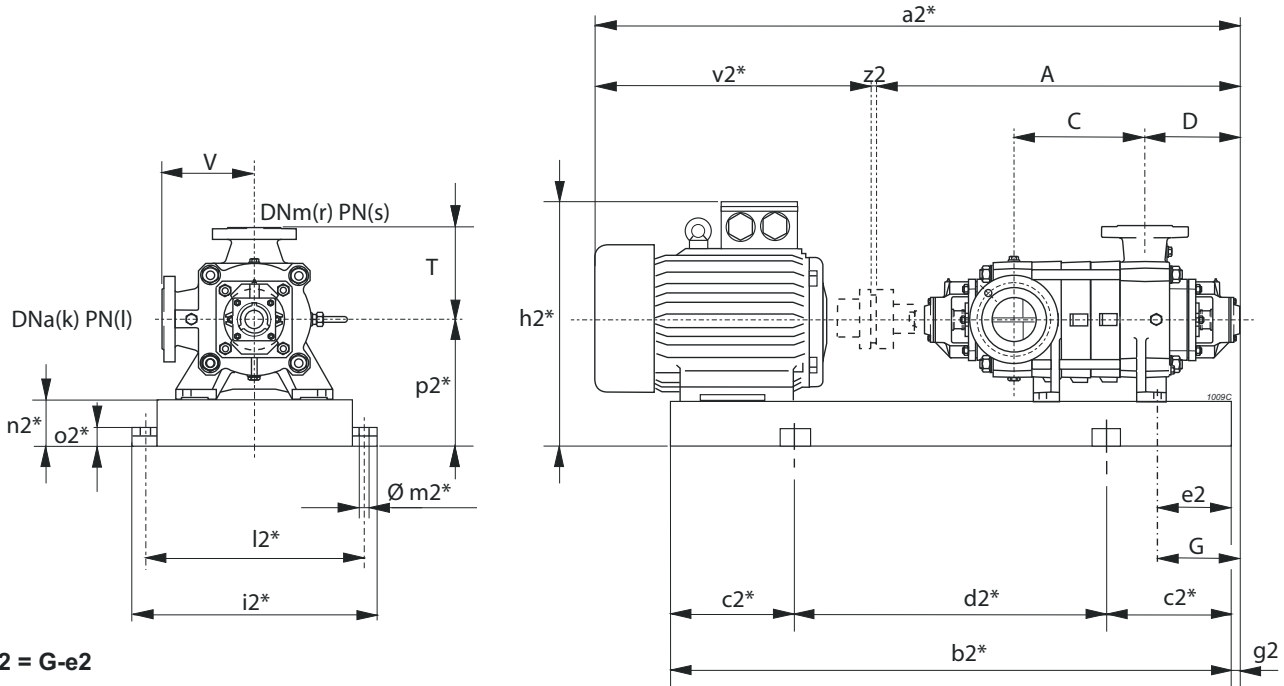

$g_2 = G - e_2$

* Valori indicativi in funzione della marca di motore utilizzato - Indicatives values according to the type of motor installed - Приблизительные значения в зависимости от марки двигателя

Pump Насос Pompa		Motor Двигатель Motore		BGAM	A	C	D	G	T	V	a ₂ *	b ₂ *	c ₂ *	d ₂ *	e ₂	h ₂ *	i ₂ *	k	l	l ₂ *	m ₂ *	n ₂ *	o ₂ *	p ₂ *	r	s	v ₂ *	z ₂	Weight Вес Peso
Series Серия Serie	Type Тип Tipo	[kW]	Size Размер Grand.	Type Тип Tipo	[mm]																						[kg]		
PMX(S/H)T	125/2	15	160L	345/EP	1033	245	337	294	320	320	1664	1340	200	940	60	671	700	150	(1)	650	20	140	42	420	125	(2)	627	4	684
PMX(S/H)T	/2	18,5	180M	346/FP	1033	245	337	294	320	320	1702	1350	250	850	60	690	700	150	(1)	650	20	140	42	420	125	(2)	665	4	765
PMX(S/H)T	/2	22	180L	347/FP	1033	245	337	294	320	320	1742	1388	250	888	60	690	700	150	(1)	650	20	140	42	420	125	(2)	705	4	786
PMX(S/H)T	/2	30	200L	348/GP	1033	245	337	294	320	320	1795	1423	250	923	60	720	700	150	(1)	650	20	140	42	420	125	(2)	758	4	821
PMX(S/H)T	/2	37	225S	4008/HR	1033	245	337	294	320	320	1830	1454	250	954	60	750	700	150	(1)	650	20	140	42	420	125	(2)	793	4	836
PMX(S/H)T	125/3	22	180L	849/FP	1133	345	337	294	320	320	1842	1488	250	988	60	690	700	150	(1)	650	20	140	42	420	125	(2)	705	4	836
PMX(S/H)T	/3	30	200L	349/GP	1133	345	337	294	320	320	1895	1523	250	1023	60	720	700	150	(1)	650	20	140	42	420	125	(2)	758	4	871
PMX(S/H)T	/3	37	225S	350/HR	1133	345	337	294	320	320	1930	1554	250	1054	60	750	700	150	(1)	650	20	140	42	420	125	(2)	793	4	886
PMX(S/H)T	/3	45	225M	351/HR	1133	345	337	294	320	320	1955	1579	250	1079	60	750	700	150	(1)	650	20	140	42	420	125	(2)	818	4	929
PMX(S/H)T	/3	55	250M	4009/IR	1133	345	337	294	320	320	2017	1621	250	1121	60	795	700	150	(1)	650	20	140	42	420	125	(2)	880	4	1052
PMX(S/H)T	125/4	30	200L	352/GP	1233	445	337	294	320	320	1995	1623	250	1123	60	720	700	150	(1)	650	20	140	42	420	125	(2)	758	4	921
PMX(S/H)T	/4	37	225S	471/HR	1233	445	337	294	320	320	2030	1654	300	1054	60	750	700	150	(1)	650	20	140	42	420	125	(2)	793	4	937
PMX(S/H)T	/4	45	225M	472/HR	1233	445	337	294	320	320	2055	1679	300	1079	60	750	700	150	(1)	650	20	140	42	420	125	(2)	818	4	979
PMX(S/H)T	/4	55	250M	473/IR	1233	445	337	294	320	320	2117	1721	300	1121	60	795	700	150	(1)	650	20	140	42	420	125	(2)	880	4	1102
PMX(S/H)T	/4	75	280S	474/IR	1233	445	337	294	320	320	2250	1768	300	1168	60	815	700	150	(1)	650	20	140	42	420	125	(2)	1013	4	1244
PMX(S/H)T	125/5	37	225S	813/HR	1333	545	337	294	320	320	2130	1754	300	1154	60	750	700	150	(1)	650	20	140	42	420	125	(2)	793	4	987
PMX(S/H)T	/5	45	225M	475/HR	1333	545	337	294	320	320	2155	1779	300	1179	60	750	700	150	(1)	650	20	140	42	420	125	(2)	818	4	1029
PMX(S/H)T	/5	55	250M	476/IR	1333	545	337	294	320	320	2217	1821	300	1221	60	795	700	150	(1)	650	20	140	42	420	125	(2)	880	4	1153
PMX(S/H)T	/5	75	280S	477/IR	1333	545	337	294	320	320	2350	1868	300	1268	60	815	700	150	(1)	650	20	140	42	420	125	(2)	1013	4	1294
PMX(S/H)T	/5	90	280M	4005/LR	1333	545	337	294	320	320	2401	1919	300	1319	60	815	700	150	(1)	650	20	140	42	420	125	(2)	1064	4	1363
PMX(S/H)T	125/6	45	225M	478/HR	1433	645	337	294	320	320	2255	1879	300	1279	60	750	700	150	(1)	650	20	140	42	420	125	(2)	818	4	1080
PMX(S/H)T	/6	55	250M	479/IR	1433	645	337	294	320	320	2317	1921	300	1321	60	795	700	150	(1)	650	20	140	42	420	125	(2)	880	4	1203
PMX(S/H)T	/6	75	280S	480/IR	1433	645	337	294	320	320	2450	1968	350	1268	60	815	700	150	(1)	650	20	140	42	420	125	(2)	1013	4	1344
PMX(S/H)T	/6	90	280M	481/LR	1433	645	337	294	320	320	2501	2019	350	1319	60	815	700	150	(1)	650	20	140	42	420	125	(2)	1064	4	1414
PMX(S/H)T	/6	110	315S	498/LR	1433	645	337	294	320	320	2648	2125	350	1425	90	1030	780	150	(1)	730	22	160	50	475	125	(2)	1211	4	1747
PMX(S/H)T	125/7	55	250M	482/IR	1533	745	337	294	320	320	2417	2021	350	1321	60	795	700	150	(1)	650	20	140	42	420	125	(2)	880	4	1253
PMX(S/H)T	/7	75	280S	483/IR	1533	745	337	294	320	320	2550	2068	350	1368	60	815	700	150	(1)	650	20	140	42	420	125	(2)	1013	4	1395
PMX(S/H)T	/7	90	280M	484/LR	1533	745	337	294	320	320	2601	2119	350	1419	60	815	700	150	(1)	650	20	140	42	420	125	(2)	1064	4	1464
PMX(S/H)T	/7	110	315S	485/LR	1533	745	337	294	320	320	2748	2225	350	1525	90	1030	780	150	(1)	730	22	160	50	475	125	(2)	1211	4	1798

BGAM = Base and coupling

* = Indicatives values according to the type of motor installed.

○ Motor in IE4 efficiency class according to EU REGULATION 2019/1781. Available in other efficiency classes for non-EU markets.

- (1) PMXT=25 bar PMXST=25 bar PMXHT=40 bar
- (2) PMXT=40 bar PMXST=63 bar PMXHT=100 bar

BGAMA = Рама и муфта

* = Приблизит. значения в зависимости от марки двигателя.

○ Двигатель класса эффективности IE4 в соответствии с РЕГУЛАМЕНТОМ ЕС 2019/1781. Имеются варианты в других классах эффективности для рынков за пределами ЕС.

- (1) PMXT=25 бар PMXST=25 бар PMXHT=40 бар
- (2) PMXT=40 бар PMXST=63 бар PMXHT=100 бар

BGAM = Base giunto e coprigiunto

* = Valori indicativi in funzione della marca di motore utilizzato.

○ Motore in classe di efficienza IE4 in conformità al REGOLAMENTO UE2019/1781. Disponibili in altre classi di efficienza per mercati extra UE.

- (1) PMXT=25 bar PMXST=25 bar PMXHT=40 bar
- (2) PMXT=40 bar PMXST=63 bar PMXHT=100 bar

Selection - dimensions and weights for base mounted electric pumps
 Подбор - габариты и вес электронасосов на раме
 Selezione - dimensioni e pesi elettropompe su base

COUPLINGS WITH STANDARDIZED ENCLOSED ELECTRIC MOTORS
 СОЕДИНЕНИЕ С НОРМАЛИЗОВАННЫМИ ЗАКРЫТЫМИ ЭЛЕКТРОДВИГАТЕЛЯМИ
 ACCOPPIAMENTI CON MOTORI ELETTRICI CHIUSI NORMALIZZATI

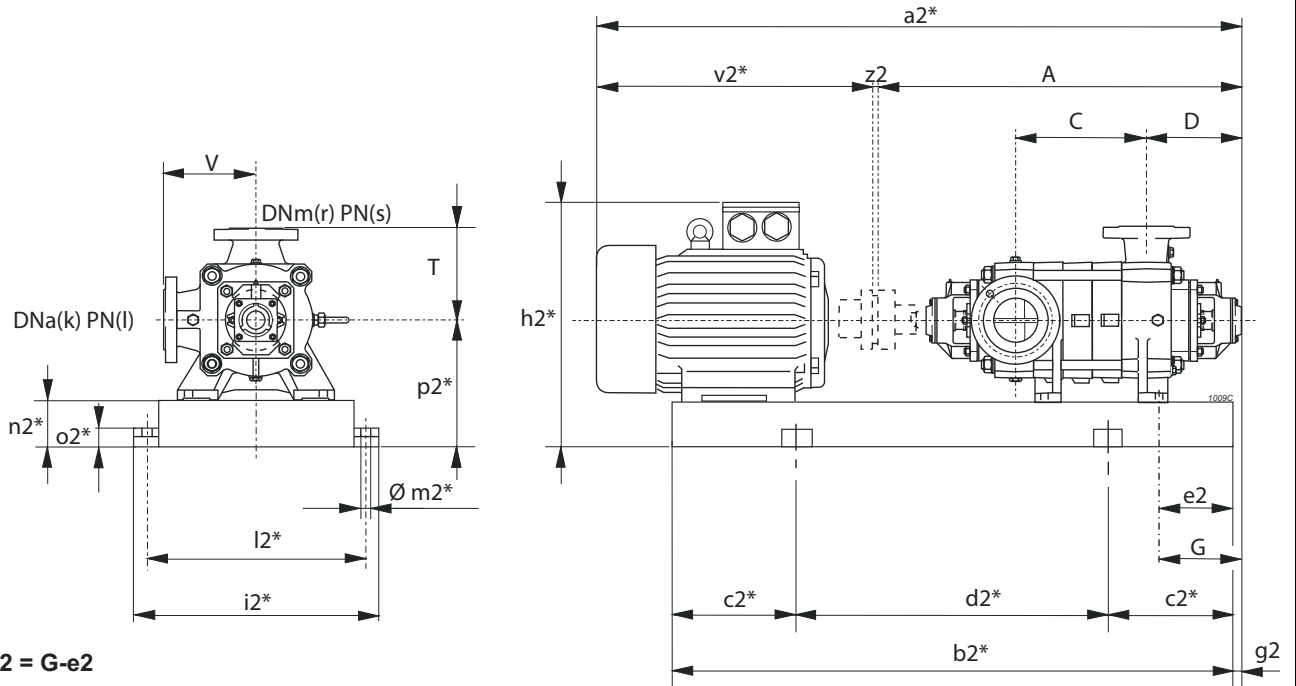

g2 = G-e2

* Valori indicativi in funzione della marca di motore utilizzato - Indicatives values according to the type of motor installed - Приблизительные значения в зависимости от марки двигателя

Pump Насос Помпа		Motor Двигатель Motore		BGAM	A	C	D	G	T	V	a2*	b2*	c2*	d2*	e2	h2*	i2*	k	l	l2*	m2*	n2*	o2*	p2*	r	s	v2*	z2	Weight Вес Peso
Series Серия Serie	Type Тип Tipo	[kW]	Size Размер Grand.	Type Тип Tipo	[mm]																								[kg]
PMX(S/H)T	/7	132	315M	4007/MR	1533	745	337	294	320	320	2858	2284	400	1484	90	1030	780	150	(1)	730	22	160	50	475	125	(2)	1321	4	1924
PMX(S/H)T	125/8	55	250M	818/IR	1633	845	337	294	320	320	2517	2121	350	1421	60	795	700	150	(1)	650	20	140	42	420	125	(2)	880	4	1303
PMX(S/H)T	/8	75	280S	486/IR	1633	845	337	294	320	320	2650	2168	350	1468	60	815	700	150	(1)	650	20	140	42	420	125	(2)	1013	4	1445
PMX(S/H)T	/8	90	280M	487/LR	1633	845	337	294	320	320	2701	2219	350	1519	60	815	700	150	(1)	650	20	140	42	420	125	(2)	1064	4	1514
PMX(S/H)T	/8	110	315S	488/LR	1633	845	337	294	320	320	2848	2325	400	1525	90	1030	780	150	(1)	730	22	160	50	475	125	(2)	1211	4	1848
PMX(S/H)T	/8	132	315M	489/MR	1633	845	337	294	320	320	2958	2384	400	1584	90	1030	780	150	(1)	730	22	160	50	475	125	(2)	1321	4	1975
PMX(S/H)T	125/9	75	280S	490/IR	1733	945	337	294	320	320	2750	2268	400	1468	60	815	700	150	(1)	650	20	140	42	420	125	(2)	1013	4	1495
PMX(S/H)T	/9	90	280M	491/LR	1733	945	337	294	320	320	2801	2319	400	1519	60	815	700	150	(1)	650	20	140	42	420	125	(2)	1064	4	1564
PMX(S/H)T	/9	110	315S	492/LR	1733	945	337	294	320	320	2948	2425	400	1625	90	1030	780	150	(1)	730	22	160	50	475	125	(2)	1211	4	1899
PMX(S/H)T	/9	132	315M	493/MR	1733	945	337	294	320	320	3058	2535	400	1735	90	1030	780	150	(1)	730	22	160	50	475	125	(2)	1321	4	2027
PMX(S/H)T	/9	160	315L	493/MR	1733	945	337	294	320	320	3058	2535	400	1735	90	1030	780	150	(1)	730	22	160	50	475	125	(2)	1321	4	2122
PMX(S/H)T	125/10	75	280S	494/IR	1833	1045	337	294	320	320	2850	2368	400	1568	60	815	700	150	(1)	650	20	140	42	420	125	(2)	1013	4	1545
PMX(S/H)T	/10	90	280M	495/LR	1833	1045	337	294	320	320	2901	2419	400	1619	60	815	700	150	(1)	650	20	140	42	420	125	(2)	1064	4	1614
PMX(S/H)T	/10	110	315S	496/LR	1833	1045	337	294	320	320	3048	2525	400	1725	90	1030	780	150	(1)	730	22	160	50	475	125	(2)	1211	4	1950
PMX(S/H)T	/10	132	315M	497/MR	1833	1045	337	294	320	320	3158	2635	450	1735	90	1030	780	150	(1)	730	22	160	50	475	125	(2)	1321	4	2078
PMX(S/H)T	/10	160	315L	497/MR	1833	1045	337	294	320	320	3158	2635	450	1735	90	1030	780	150	(1)	730	22	160	50	475	125	(2)	1321	4	2173
PMX(S/H)T	/10	200	315L	497/IE4/MR	1833	1045	337	294	320	320	3248	2725	450	1825	198	1030	780	150	(1)	730	22	160	50	475	125	(2)	1411	4	2314

BGAM = Base and coupling

* = Indicatives values according to the type of motor installed.

○ Motor in IE4 efficiency class according to EU REGULATION 2019/1781. Available in other efficiency classes for non-EU markets.

- (1) PMXT=25 bar PMXST=25 bar PMXHT=40 bar
 (2) PMXT=40 bar PMXST=63 bar PMXHT=100 bar

BGAMA = Рама и муфта

* = Приблизит. значения в зависимости от марки двигателя.

○ Двигатель класса эффективности IE4 в соответствии с РЕГЛАМЕНТОМ ЕС 2019/1781. Имеются варианты в других классах эффективности для рынков за пределами ЕС.

- (1) PMXT=25 бар PMXST=25 бар PMXHT=40 бар
 (2) PMXT=40 бар PMXST=63 бар PMXHT=100 бар

BGAM = Base giunto e coprigiunto

* = Valori indicativi in funzione della marca di motore utilizzato.

○ Motore in classe di efficienza IE4 in conformità al REGOLAMENTO UE2019/1781. Disponibili in altre classi di efficienza per mercati extra UE.

- (1) PMXT=25 bar PMXST=25 bar PMXHT=40 bar
 (2) PMXT=40 bar PMXST=63 bar PMXHT=100 bar

Utilization field Область применения Campo di utilizzo ≥ 60% η		
Stage number: compatibly with the maximum pressure. Кол-во ступеней: совместимое с макс. давлением. Numero stadi: compatibilmente con la pressione massima di esercizio.		
Type Тип Tipo	MIN.	MAX.
PMXL T	2	10
PMXLST	2	10
NB. For two-stage pumps only, reduce efficiency by one point. Только для двухступенчатых насосов - снизить КПД на 1 единицу Solamente per le pompe a due stadi, ridurre di un punto il rendimento.		

Wet moment of inertia J Момент инерции J мокрый Momento d'inerzia J bagnato J=1/4PD ² - [kg m ²]		
Impeller type Тип раб. колеса Girante tipo	PMXL(S)T150/1	For each additional stage Для каждой доп. ступени Per ogni stadio in più
Stainless steel Нержав. сталь Acciaio inox	0,1979	0,1683

Maximum permissible power Макс. допустимая мощность Massime potenze ammissibili	
Type Тип Tipo	N/n MAX.
PMXL T	0,31
PMXLST	0,31
For seal limits and calculation formulas of the maximum permissible powers, see technical data section. Ограничения по уплотнениям и формулы расчета макс. допустимой мощности - см. раздел "Технические данные". Per i limiti tenete e le formule di calcolo delle massime potenze ammissibili, vedere sezione dati tecnici.	

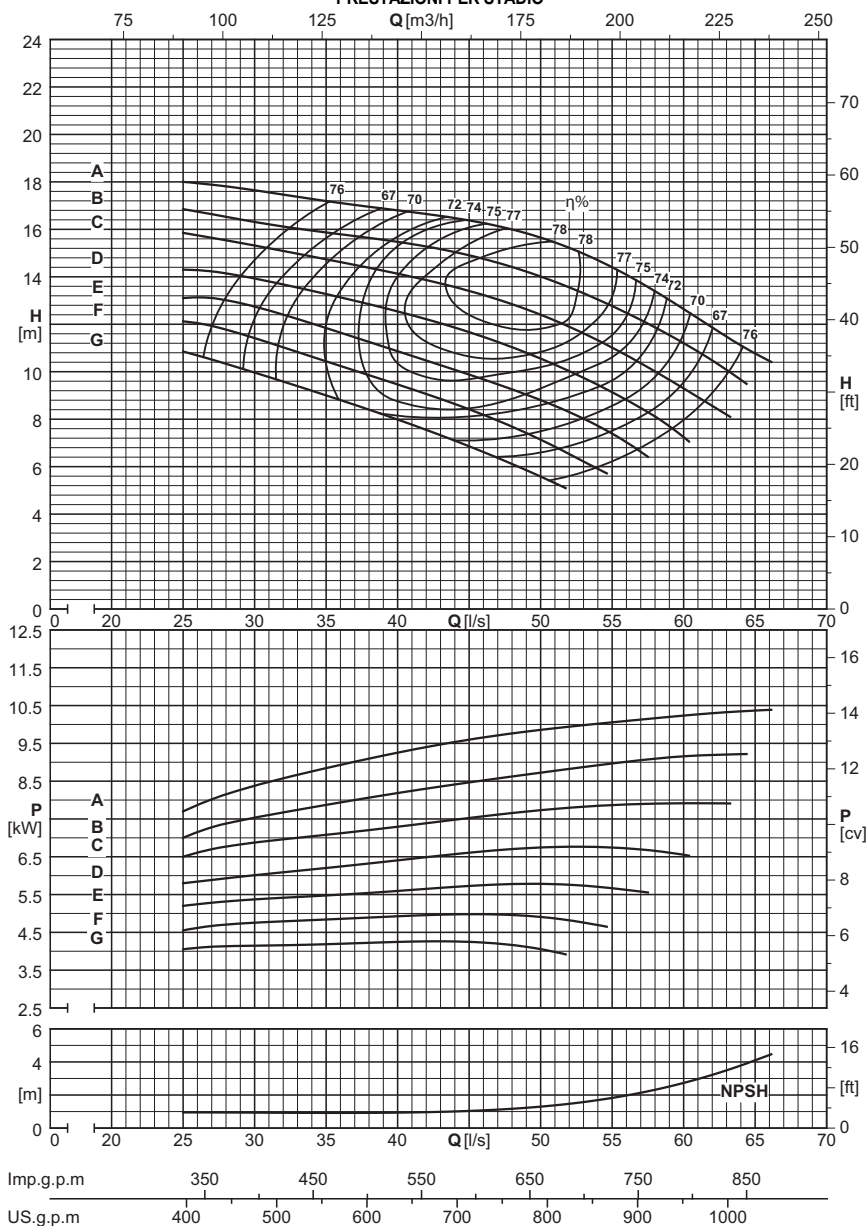
 PERFORMANCES EACH INTERMEDIATE STAGE
 ХАРАКТЕРИСТИКИ ОДНОЙ СТУПЕНИ
 PRESTAZIONI PER STADIO

Dna x DNm	Impeller type Тип раб. кол. Girante tipo	Capacity - Расход - Portata																				
		[l/s]	0	28	30	32	34	36	38	40	42	44	46	48	50	52	54	56	58	60	62	64
		[m ³ /h]	0	100,8	108	115,2	122,4	129,6	136,8	144	151,2	158,4	165,6	172,8	180	187,2	194,4	201,6	208,8	216	223,2	230,4
		[l/min]	0	1680	1800	1920	2040	2160	2280	2400	2520	2640	2760	2880	3000	3120	3240	3360	3480	3600	3720	3840

		PMXL(S)T150/1																					
200x150	G	[m]	13	10,5	10	9,6	9,2	8,8	8,4	8	7,6	7,1	6,6	6,2	5,5	5,1							
200x150	G	[kW]		4,2	4,1	4,2	4,2	4,2	4,3	4,2	4,3	4,3	4,2	4,2	4	3,9							
200x150	F	[m]	14,5	12	11,5	11	10,5	10	9,8	9,5	9,1	8,6	8,2	7,6	7,1	6,6	5,8	5,6					
200x150	F	[kW]		4,7	4,8	4,9	4,8	4,9	5	4,9	4,9	5,1	4,9	4,9	4,9	4,6	4,8						
200x150	E	[m]	15,5	13	13	12,5	12	11,5	11,5	11	10,5	10	9,7	9,3	8,8	8,3	7,7	7,1	6,4				
200x150	E	[kW]		5,3	5,4	5,4	5,5	5,6	5,5	5,6	5,7	5,8	5,9	5,7	5,7	5,7	5,6						
200x150	D	[m]	16,5	14,5	14	14	13,5	13	13	12,5	12	12	11,5	11	10,5	9,9	9,3	8,7	8	7,1	6,9		
200x150	D	[kW]		5,8	5,9	6	6,1	6,2	6,3	6,4	6,5	6,6	6,7	6,8	6,8	6,6	6,6	6,6	6,6	6,5	6,7		
200x150	C	[m]	18,5		15	14,5	14,5	14,5	14	14	13,5	13,5	13	13	12,5	12	11,5	11	10	9,5	8,7		
200x150	C	[kW]			7,1	7,1	7,2	7,3	7,3	7,4	7,5	7,6	7,7	7,8	7,9	7,9	8	8	8	8	8		
200x150	B	[m]	20			16	15,5	15,5	15,5	15,5	15	15,5	14,5	14,5	14,5	13,5	13,5	12,5	12	11	10,5	9,5	
200x150	B	[kW]					7,8	7,9	8	8,1	8,3	8,4	8,5	8,6	8,6	8,7	8,8	8,9	9	9,1	9,1	9,2	
200x150	A	[m]	23					17	17,5	17	17	16,5	16,5	16,5	16	16	15	14,5	14	13,5	12,5	12	11
200x150	A	[kW]								8,8	9	9,1	9,2	9,4	9,5	9,6	9,6	9,7	10,1	10,1	10,2	10,3	10,4

		NPSH																					
	[m]		0,9	0,9	0,9	0,9	0,9	0,9	0,9	0,9	0,9	1	1	1,1	1,2	1,3	1,5	1,7	2	2,3	2,8	3,2	3,8

1450 n [min⁻¹]

Utilization field Область применения Campo di utilizzo ≥ 60% η		
Stage number: compatibly with the maximum pressure. Кол-во ступеней: совместимое с макс. давлением. Numero stadi: compatibilmente con la pressione massima di esercizio.		
Type Тип Tipo	MIN.	MAX.
PMXLT	2	10
PMXLST	2	10
NB. For two-stage pumps only, reduce efficiency by one point. Только для двухступенчатых насосов - снизить КПД на 1 единицу Solamente per le pompe a due stadi, ridurre di un punto il rendimento.		

Wet moment of inertia J Момент инерции J мокрый Momento d'inerzia J bagnato J=¼PD ² - [kg m ²]		
Impeller type Тип раб. колеса Girante tipo	PMXL(S)T150/1	For each additional stage Для каждой доп. ступени Per ogni stadio in più
Stainless steel Нержав. сталь Acciaio inox	0,1979	0,1683

Maximum permissible power Макс. допустимая мощность Massime potenze ammissibili	
Type Тип Tipo	N/n MAX.
PMXLT	0,31
PMXLST	0,31
For seal limits and calculation formulas of the maximum permissible powers, see technical data section. Ограничения по уплотнениям и формулы расчета макс. допустимой мощности - см. раздел "Технические данные". Per i limiti tenute e le formule di calcolo delle massime potenze ammissibili, vedere sezione dati tecnici.	

PERFORMANCES EACH INTERMEDIATE STAGE
ХАРАКТЕРИСТИКИ ОДНОЙ СТУПЕНИ
PRESTAZIONI PER STADIO

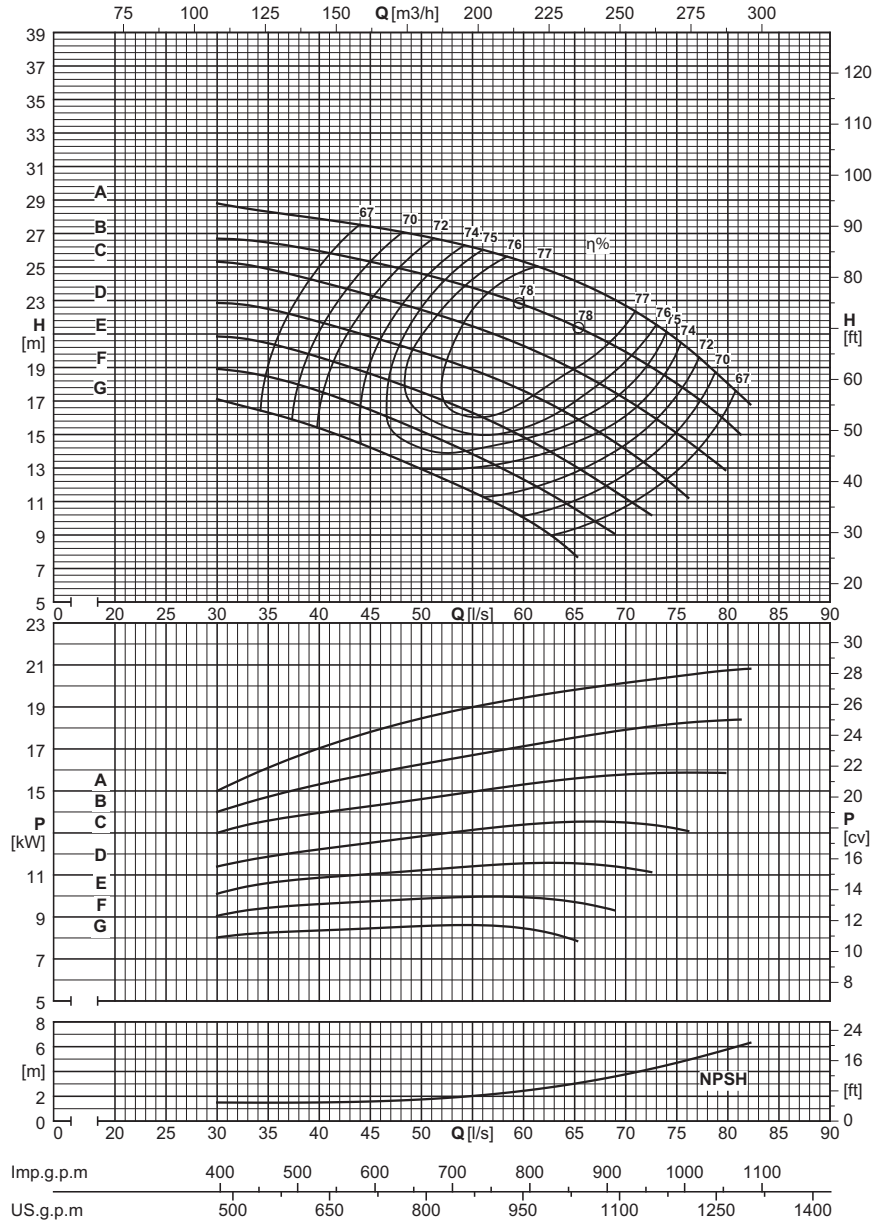

Dna x Dnm	Impeller type Тип раб. кол. Girante tipo	Capacity - Расход - Portata																						
		[l/s]	0	40	42	44	46	48	50	52	54	56	58	60	62	64	66	68	70	72	74	76	78	80
		[m³/h]	0	144	151,2	158,4	165,6	172,8	180	187,2	194,4	201,6	208,8	216	223,2	230,4	237,6	244,8	252	259,2	266,4	273,6	280,8	288
		[l/min]	0	2400	2520	2640	2760	2880	3000	3120	3240	3360	3480	3600	3720	3840	3960	4080	4200	4320	4440	4560	4680	4800

		PMXL(S)T150/1																						
200x150	G	[m]	20,5	15	15	14,5	14,5	13,5	13	12,5	12	11,5	10,5	10	9,4	8,6								
200x150	G	[kW]		8,5	8,6	8,3	8,4	8,4	8,5	8,6	8,6	8,6	8,6	8,5	8,4	8,2								
200x150	F	[m]	22,5	17,5	17	16,5	16,5	15,5	15	14,5	14	13,5	13	12	11,5	11	10	9,2	8,9					
200x150	F	[kW]		9,6	9,6	9,7	9,7	9,7	9,8	9,8	9,9	9,9	9,9	9,8	9,7	9,6	9,4	9,2	9,5					
200x150	E	[m]	24,5	19,5	20	18,5	18,5	19	17,5	17	16,5	16,5	15,5	15	14,5	13,5	13	12	11	10,5	10			
200x150	E	[kW]		11,1	11,1	11,1	11,1	11,2	11,2	11,2	11,3	11,3	11,3	11,7	11,7	11,7	11,6	11,4	11,3	11,1	11,4			
200x150	D	[m]	26,5	21,5	21,5	21	21	20	20	19,5	19	18,5	18	17,5	17,5	16,5	15,5	15	14,5	13,5	12,5	11	11	
200x150	D	[kW]		12,3	12,3	12,3	12,4	12,9	13	13	13	13,1	13,1	13,6	13,5	13,5	13,5	13,4	13,8	13,6	13,4	13,1	13,4	
200x150	C	[m]	29,5	24,5	24	23	23,5	23	22,5	22	21,5	21,5	21	20	19,5	19	18,5	17,5	17	16,5	15,5	14,5	14,5	
200x150	C	[kW]		13,8	13,8	14,5	14,4	14,4	14,4	15	15	15	15	15,5	15,5	15,5	15,5	15,5	16	16	16	15,5	16	
200x150	B	[m]	32	26,5	25	25	25,5	25	24	24	24,5	24	23,5	22,5	22,5	22	21	20,5	20	19	18,5	17,5	16,5	15
200x150	B	[kW]		15	16	16	16	16	16,5	16,5	16,5	16,5	17	17	17	17,5	18	18	18	18	18,5	18,5	18	18
200x150	A	[m]	37	28,5	27	27,5	27,5	27,5	26,5	26,5	26,5	25,5	25,5	25,5	25	24,5	24	23,5	22,5	22	21	20	19,5	18
200x150	A	[kW]		17	17,5	17,5	18	18	18,5	18,5	18,5	19,5	19,5	19,5	20	20	20	20	20,5	20,5	20,5	21	21	

		NPSH																				
	[m]	1,5	1,5	1,6	1,6	1,7	1,7	1,8	2	2,1	2,3	2,5	2,7	2,9	3,1	3,5	3,8	4,1	4,5	4,9	5,4	5,8

Utilization field Область применения Campo di utilizzo ≥ 60% η		
Stage number: compatibly with the maximum pressure. Кол-во ступеней: совместимое с макс. давлением. Numero stadi: compatibilmente con la pressione massima di esercizio.		
Type Тип Tipo	MIN.	MAX.
PMXL T	2	10
PMXLST	2	10
NB. For two-stage pumps only, reduce efficiency by one point. Только для двухступенчатых насосов - снизить КПД на 1 единицу Solamente per le pompe a due stadi, ridurre di un punto il rendimento.		

Wet moment of inertia J Момент инерции J мокрый Momento d'inerzia J bagnato J=1/4PD ² - [kg m ²]		
Impeller type Тип раб. колеса Girante tipo	PMXL(S)T150/1	For each additional stage Для каждой доп. ступени Per ogni stadio in più
Stainless steel Нержав. сталь Acciaio inox	0,1979	0,1683

Maximum permissible power Макс. допустимая мощность Massime potenze ammissibili	
Type Тип Tipo	N/n MAX.
PMXL T	0,31
PMXLST	0,31
For seal limits and calculation formulas of the maximum permissible powers, see technical data section. Ограничения по уплотнениям и формулы расчета макс. допустимой мощности - см. раздел "Технические данные". Per i limiti tenete e le formule di calcolo delle massime potenze ammissibili, vedere sezione dati tecnici.	

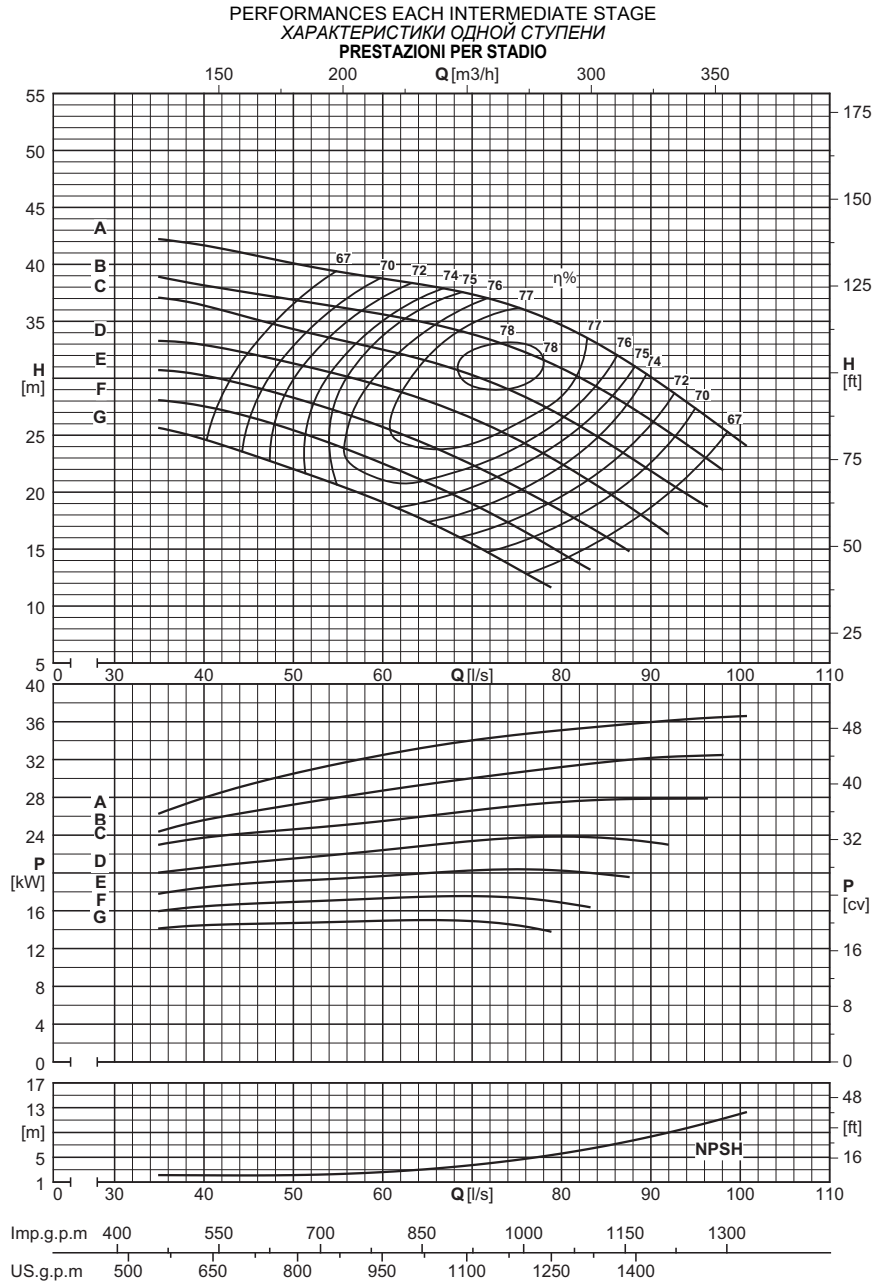

Dna x DNm	Impeller type Тип раб. кол. Girante tipo	Capacity - Расход - Portata																	
		[l/s]	0	38	42	46	50	54	58	62	66	70	74	78	82	86	90	94	98
		[m ³ /h]	0	136,8	151,2	165,6	180	194,4	208,8	223,2	237,6	252	266,4	280,8	295,2	309,6	324	338,4	352,8
		[l/min]	0	2280	2520	2760	3000	3240	3480	3720	3960	4200	4440	4680	4920	5160	5400	5640	5880

		PMXL(S)T150/1																				
		[m]	29,5	25	24	23	22	21	19,5	18,5	17	15,5	13,5	12	11							
200x150	G	[kW]		14,6	14,6	14,5	14,4	14,9	14,8	15,5	15	14,5	13,7	14,4								
200x150	F	[m]	32,5		27,5	26	25,5	24,5	23	22	20,5	19	17,5	15,5	13,5	13						
200x150	F	[kW]			16,5	17	17	16,5	17,5	17	17,5	17,5	17,5	17	16	17						
200x150	E	[m]	35		30,5	29	28	27,5	26	25	24	22,5	21	20	17,5	16,5	14,5					
200x150	E	[kW]			18	19	19,5	19	20	19,5	20	20	20,5	20	20	20						
200x150	D	[m]	38,5			32,5	31,5	30	30	29	27,5	26,5	25,5	23,5	21,5	19,5	18	16,5				
200x150	D	[kW]				21	21,5	22	22	22,5	23,5	23	23,5	24	23,5	23,5	23,5	23,5				
200x150	C	[m]	42,5				34,5	35	33,5	32,5	31,5	31,5	30,5	30	27,5	25,5	24	22	20			
200x150	C	[kW]					25	24	25	25,5	26	26	26,5	27	27,5	27	27,5	28	28			
200x150	B	[m]	46,5					38	37	36,5	35	34,5	34	33,5	31,5	30	28,5	26,5	24,5	22		
200x150	B	[kW]							26,5	27,5	28,5	29	30	29,5	30,5	31	31,5	32	32	32,5		
200x150	A	[m]	53							40,5	39,5	39	39	37	36,5	35	34	32	30	29	26	
200x150	A	[kW]									30,5	31,5	32,5	33,5	34	35	35,5	35	35,5	36	36,5	37

		NPSH																		
		[m]	2,1	2,1	2,1	2,1	2,3	2,5	2,8	3,2	3,7	4,4	5,2	6,1	7,1	8,3	9,6	11,2		

Utilization field Область применения Campo di utilizzo ≥ 60% η		
Stage number: compatibly with the maximum pressure. Кол-во ступеней: совместимое с макс. давлением. Numero stadi: compatibilmente con la pressione massima di esercizio.		
Type Тип Tipo	MIN.	MAX.
PMXLT	2	8
PMXLST	2	8
NB. For two-stage pumps only, reduce efficiency by one point. Только для двухступенчатых насосов - снизить КПД на 1 единицу Solamente per le pompe a due stadi, ridurre di un punto il rendimento.		

Wet moment of inertia J Момент инерции J мокрый Momento d'inerzia J bagnato J=¼PD ² - [kg m ²]		
Impeller type Тип раб. колеса Girante tipo	PMXL(S)T150/1	For each additional stage Для каждой доп. ступени Per ogni stadio in più
Stainless steel Нержав. сталь Acciaio inox	0,1979	0,1683

Maximum permissible power Макс. допустимая мощность Massime potenze ammissibili	
Type Тип Tipo	N/n MAX.
PMXLT	0,31
PMXLST	0,31
For seal limits and calculation formulas of the maximum permissible powers, see technical data section. Ограничения по уплотнениям и формулы расчета макс. допустимой мощности - см. раздел "Технические данные". Per i limiti tenute e le formule di calcolo delle massime potenze ammissibili, vedere sezione dati tecnici.	

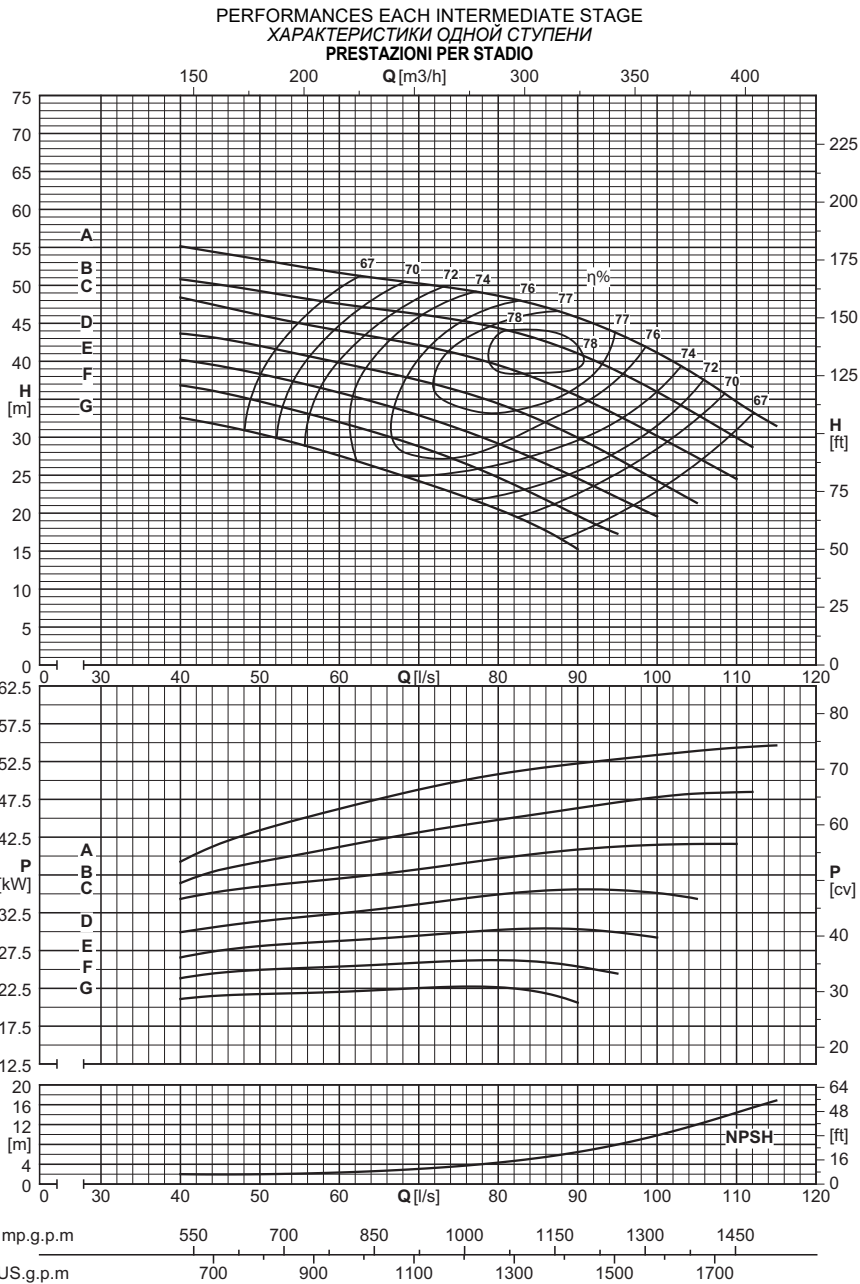

Dna x Dnm	Impeller type Тип раб. кол. Girante tipo	Capacity - Расход - Portata																		
		[l/s]	0	48	52	56	60	64	68	72	76	80	84	88	92	96	100	104	108	112
		[m ³ /h]	0	172,8	187,2	201,6	216	230,4	244,8	259,2	273,6	288	302,4	316,8	331,2	345,6	360	374,4	388,8	403,2
		[l/min]	0	2880	3120	3360	3600	3840	4080	4320	4560	4800	5040	5280	5520	5760	6000	6240	6480	6720

		PMXL(S)T150/1																			
		[m]	38,5	31	30,5	28,5	27,5	26	25	23,5	22	20,5	18,5	17	15						
200x150	G	[kW]		21,5	21,5	22	21,5	22,5	22	22,5	22,5	23	22	21,5	21						
200x150	F	[m]	42,5	35,5	34,5	33,5	32	30,5	29,5	28	26,5	24,5	23	20,5	18,5	17					
200x150	F	[kW]		24,5	25	24,5	25,5	26	25,5	26	26,5	26,5	25	25,5	24,5						
200x150	E	[m]	46	39,5	38	37	35,5	35	33,5	32	30,5	29	27,5	25,5	24	21,5	19,5				
200x150	E	[kW]		27	29	28,5	29	28,5	29	30	30,5	30	30,5	31	29,5	29					
200x150	D	[m]	50		42,5	41,5	40	39	38	36,5	36,5	34,5	33	31	30	27,5	23,5	21,5	21		
200x150	D	[kW]			31	31,5	32	33	33,5	34,5	34	34,5	35	35,5	36	36,5	34,5	34,5	35,5		
200x150	C	[m]	55			44,5	43	44	43	42	41	39,5	38	36,5	34,5	32,5	30,5	28,5	26		
200x150	C	[kW]				37,5	38	36,5	37,5	38	39	39,5	40	40,5	41	41,5	42	42	42,5		
200x150	B	[m]	61			47,5	47	46,5	45,5	45	44,5	45	43,5	42	40	38	36	33,5	31	28,5	
200x150	B	[kW]				41	41,5	42,5	43,5	44	45,5	44	45	45,5	46,5	47,5	47,5	49	48,5	48,5	
200x150	A	[m]	70				51	50	50	49,5	49	48,5	47,5	46,5	45	43	41	40	36,5	33,5	
200x150	A	[kW]					46,5	47,5	48,5	49,5	50,5	51	51,5	52,5	53	53,5	53,5	54	54,5	55	

		NPSH																			
		[m]	2	2	2,2	2,3	2,6	2,9	3,3	3,7	4,3	5,1	5,9	7	8,1	9,8	11,7	13,5	15,4		

Utilization field Область применения Campo di utilizzo ≥ 60% η		
Stage number: compatibly with the maximum pressure. Кол-во ступеней: совместимое с макс. давлением. Numero stadi: compatibilmente con la pressione massima di esercizio.		
Type Тип Tipo	MIN.	MAX.
PMXL T	2	7
PMXLST	2	7
NB. For two-stage pumps only, reduce efficiency by one point. Только для двухступенчатых насосов - снизить КПД на 1 единицу Solamente per le pompe a due stadi, ridurre di un punto il rendimento.		

Wet moment of inertia J Момент инерции J мокрый Momento d'inerzia J bagnato J=1/4PD ² - [kg m ²]		
Impeller type Тип раб. колеса Girante tipo	PMXL(S)T150/1	For each additional stage Для каждой доп. ступени Per ogni stadio in più
Stainless steel Нержав. сталь Acciaio inox	0,1979	0,1683

Maximum permissible power Макс. допустимая мощность Massime potenze ammissibili	
Type Тип Tipo	N/n MAX.
PMXL T	0,31
PMXLST	0,31
For seal limits and calculation formulas of the maximum permissible powers, see technical data section. Ограничения по уплотнениям и формулы расчета макс. допустимой мощности - см. раздел "Технические данные". Per i limiti tenete e le formule di calcolo delle massime potenze ammissibili, vedere sezione dati tecnici.	

PERFORMANCES EACH INTERMEDIATE STAGE
ХАРАКТЕРИСТИКИ ОДНОЙ СТУПЕНИ
PRESTAZIONI PER STADIO

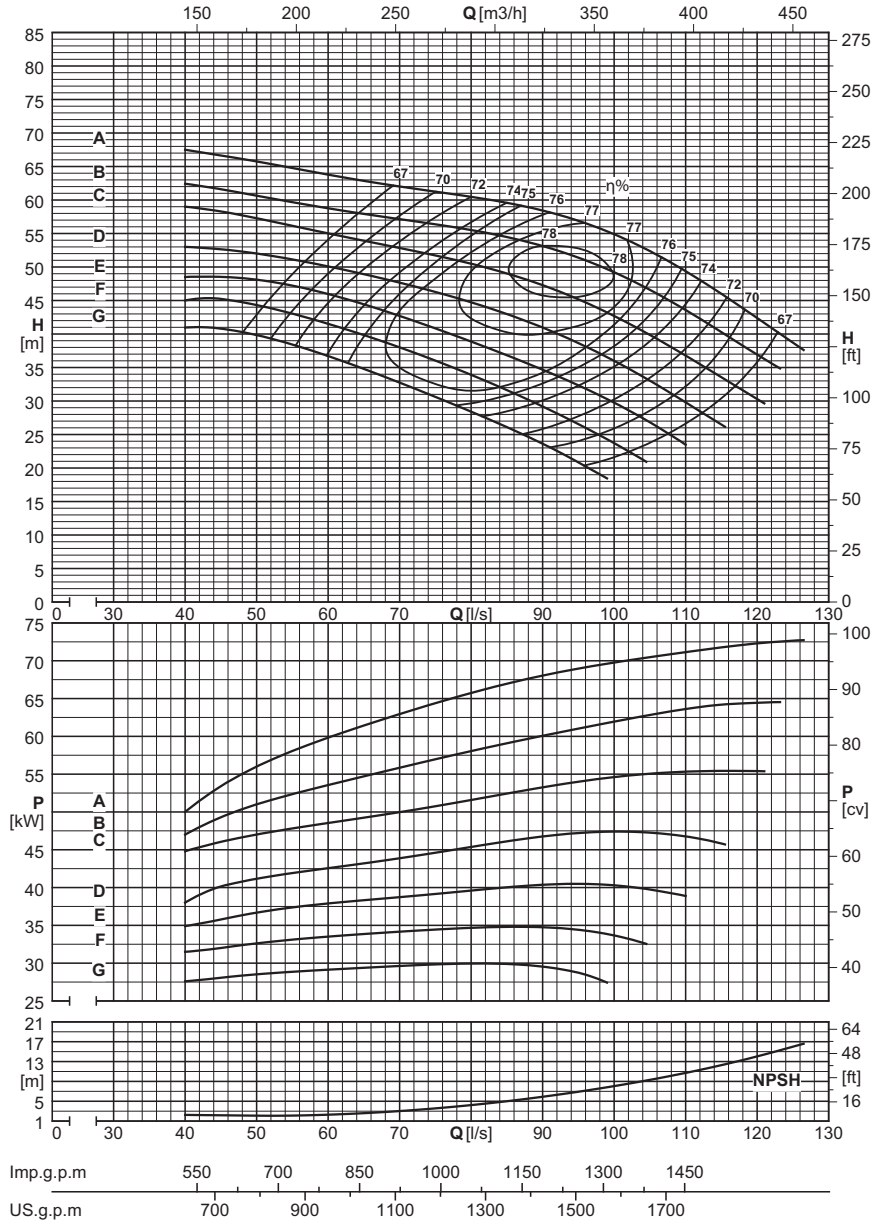

Dna x DNm	Impeller type Тип раб. кол. Girante tipo	Capacity - Расход - Portata																				
		[l/s]	0	52	56	60	64	68	72	76	80	84	88	92	96	100	104	108	112	116	120	124
		[m³/h]	0	187,2	201,6	216	230,4	244,8	259,2	273,6	288	302,4	316,8	331,2	345,6	360	374,4	388,8	403,2	417,6	432	446,4
		[l/min]	0	3120	3360	3600	3840	4080	4320	4560	4800	5040	5280	5520	5760	6000	6240	6480	6720	6960	7200	7440

		PMXL(S)T150/1																					
200x150	G	[m]	47	39,5	38	36,5	35,5	33,5	32	30	28,5	26,5	25	22,5	20,5	18,5							
200x150	G	[kW]		28,5	29	29,5	30	29,5	30	29,5	30	30	30,5	29	28,5	27,5							
200x150	F	[m]	51	44,5	43	41,5	40	38,5	37,5	35,5	34	32	30	28,5	26,5	23,5	21	20					
200x150	F	[kW]		32	32,5	33,5	34	34,5	35	34,5	34,5	35,5	35	35	33	32,5	33,5						
200x150	E	[m]	55	47	46	45	45,5	44	42	40,5	39	37,5	35,5	34	32	28	25,5	23					
200x150	E	[kW]		37,5	38	39	37,5	38	38,5	39	39,5	40	40,5	40,5	41	41	40,5	40	39,5				
200x150	D	[m]	60		50	50	49	48	47,5	46	44,5	43,5	42	40	38	36	34	31,5	28,5	26,5			
200x150	D	[kW]			42	42,5	43	43,5	44,5	45	45,5	46	46,5	47	47,5	47,5	47	46,5	46				
200x150	C	[m]	67		56	55	55	54	53	50	50	49	48	46,5	44,5	42,5	40,5	39	35,5	32,5			
200x150	C	[kW]			47	47,5	48	48,5	49	52	52,5	53	53,5	54	54,5	54,5	55,5	55	55	55			
200x150	B	[m]	73			60	56	56	55	55	54	53	52	51	49	47,5	44,5	43	40	37,5	34,5		
200x150	B	[kW]				52,5	56	56,5	57	57,5	58,5	60	59,5	60	61	61,5	62	62,5	64,5	65,5	65,5	65	
200x150	A	[m]	84				62	61	61	61	61	60	59	57	56	54	52	50	48	45	41,5	40,5	
200x150	A	[kW]					62	63	63,5	64,5	65	66	66,5	69,5	70	70	70,5	70,5	71	71	71,5	73,5	

		NPSH																		
	[m]	2,1	2,1	2,3	2,5	2,8	3,2	3,7	4,2	4,9	5,5	6,3	7,1	8	9	10,2	11,2	12,5	14,3	15,4

2900 n [min⁻¹]

Utilization field Область применения Campo di utilizzo ≥ 60% η		
Stage number: compatibly with the maximum pressure. Кол-во ступеней: совместимое с макс. давлением. Numero stadi: compatibilmente con la pressione massima di esercizio.		
Type Тип Tipo	MIN.	MAX.
PMXLT	2	4
PMXLST	2	4
NB. For two-stage pumps only, reduce efficiency by one point. Только для двухступенчатых насосов - снизить КПД на 1 единицу Solamente per le pompe a due stadi, ridurre di un punto il rendimento.		

Wet moment of inertia J Момент инерции J мокрый Momento d'inerzia J bagnato J=1/4PD ² - [kg m ²]		
Impeller type Тип раб. колеса Girante tipo	PMXL(S)T150/1	For each additional stage Для каждой доп. ступени Per ogni stadio in più
Stainless steel Нержав. сталь Acciaio inox	0,1979	0,1683

Maximum permissible power Макс. допустимая мощность Massime potenze ammissibili	
Type Тип Tipo	N/n MAX.
PMXLT	0,31
PMXLST	0,31
For seal limits and calculation formulas of the maximum permissible powers, see technical data section. Ограничения по уплотнениям и формулы расчета макс. допустимой мощности - см. раздел "Технические данные". Per i limiti tenute e le formule di calcolo delle massime potenze ammissibili, vedere sezione dati tecnici.	

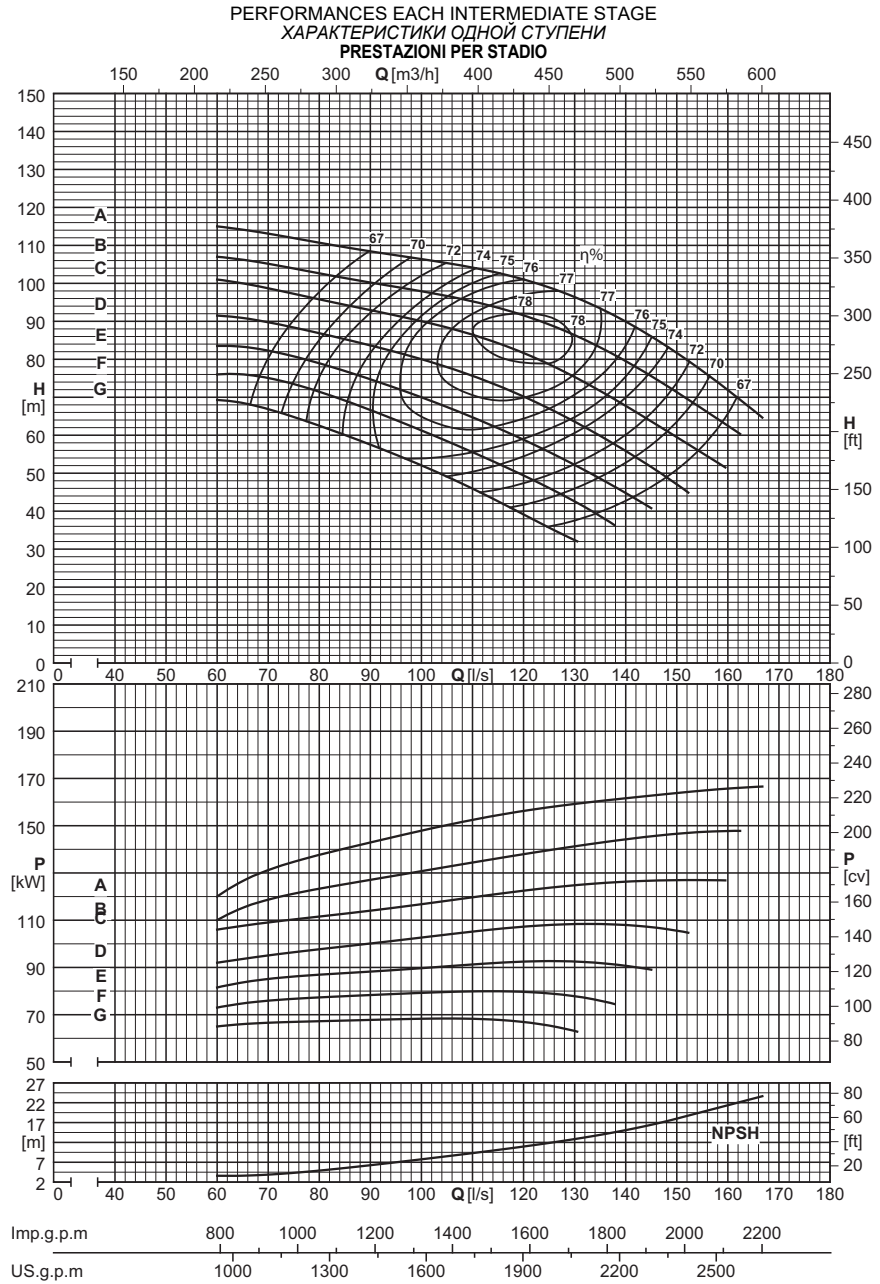

Dna x Dnm	Impeller type Тип раб. кол. Girante tipo	Capacity - Расход - Portata																									
		[l/s]	0	70	74	78	82	86	90	94	98	102	106	110	114	118	122	126	130	134	138	142	146	150	154	158	162
		[m ³ /h]	0	252	266,4	280,8	295,2	309,6	324	338,4	352,8	367,2	381,6	396	410,4	424,8	439,2	453,6	468	482,4	496,8	511,2	525,6	540	554,4	568,8	583,2
		[l/min]	0	4200	4440	4680	4920	5160	5400	5640	5880	6120	6360	6600	6840	7080	7320	7560	7800	8040	8280	8520	8760	9000	9240	9480	9720

		PMXL(S)T150/1																											
200x150	G	[m]	81	67	65	63	61	59	57	55	53	51	48,5	46,5	43	40	37,5	34,5	32	31									
200x150	G	[kW]		65,5	66	66,5	67	67,5	69	68,5	69	69	69,5	69,5	66,5	66,5	65,5	64,5	62,5	64,5									
200x150	F	[m]	89	73	72	71	69	68	66	64	62	60	57	55	53	50	48,5	45,5	42,5	39,5	36,5								
200x150	F	[kW]		77	78	78	78	79	79	79	79	80	80	80	80	80	79	78	76	74,5									
200x150	E	[m]	97	81	80	79	78	76	75	73	70	68	66	64	62	60	57	54	51	48,5	47	44	40,5						
200x150	E	[kW]		86	86	86	86	87	87	87	91	91	91	91	92	92	92	91	91	90	93	91	89						
200x150	D	[m]	105	89	89	88	87	83	83	82	81	79	76	75	73	71	68	66	64	60	57	53	50	45,5	44,5				
200x150	D	[kW]		95	95	95	96	100	100	101	101	101	105	106	106	106	106	106	109	109	108	107	105	103	105				
200x150	C	[m]	117		99	94	94	94	94	90	89	89	88	87	84	82	80	77	75	72	69	65	63	59	56				
200x150	C	[kW]			108	113	113	112	112	117	117	117	117	117	122	122	122	122	126	126	125	125	128	127	126				
200x150	B	[m]	128					101	102	97	98	98	98	94	93	92	91	88	86	83	81	78	74	70	68	64	60		
200x150	B	[kW]						124	124	124	130	130	130	130	135	135	136	136	141	141	141	145	145	145	149	148	147		
200x150	A	[m]	147					110	111	106	107	108	103	104	104	104	100	98	95	93	91	88	85	81	77	75	70		
200x150	A	[kW]						138	138	145	145	145	151	151	151	152	157	157	156	161	161	160	160	163	163	167	166		

		NPSH																									
		[m]		3,9	4,3	4,7	5,2	5,7	6,2	6,8	7,4	8	8,6	9,3	9,9	10,6	11,3	12	12,8	13,6	14,6	15,7	16,8	18	19,4	20,5	22,1

Overall dimensions and weights
 Общие габариты и вес
 Dimensioni di ingombro e pesi

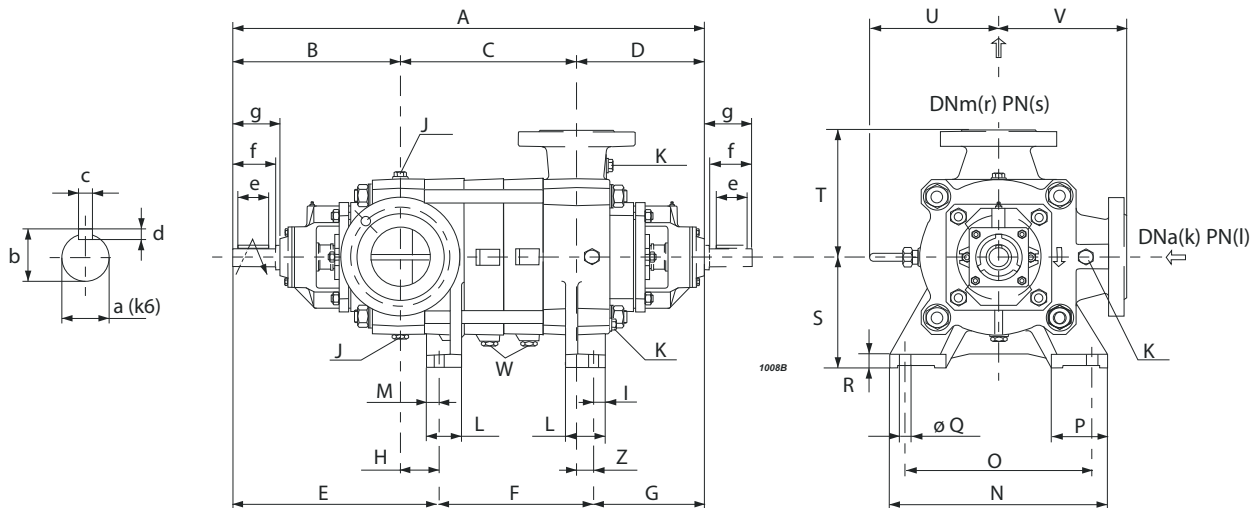

Series Серия Serie	Type Тип Tipo	A	B	C	D	E	F	G	H	S	T	U	V	Z	Weight Вес Peso
		[mm]													[kg]
PMXL(S)T	150/2	1190	479	360	351	619	270	301	140	315	370	358	370	50	711
PMXL(S)T	150/3	1315	479	485	351	619	395	301	140	315	370	358	370	50	791
PMXL(S)T	150/4	1440	479	610	351	619	520	301	140	315	370	358	370	50	872
PMXL(S)T	150/5	1565	479	735	351	619	645	301	140	315	370	358	370	50	953
PMXL(S)T	150/6	1690	479	860	351	619	770	301	140	315	370	358	370	50	1033
PMXL(S)T	150/7	1815	479	985	351	619	895	301	140	315	370	358	370	50	1114
PMXL(S)T	150/8	1940	479	1110	351	619	1020	301	140	315	370	358	370	50	1195
PMXL(S)T	150/9	2065	479	1235	351	619	1145	301	140	315	370	358	370	50	1275
PMXL(S)T	150/10	2190	479	1360	351	619	1270	301	140	315	370	358	370	50	1356

Foot dimensions Размеры ножек Dimensioni dei piedi							
I	L	M	N	O	P	Q	R
[mm]							
43	125	45	680	590	170	24	40

Shaft projection Выступ вала Sporgenza d'albero						
a	b	c	d	e	f	g
[mm]						
55	59	16	10	120	130	145

Type Тип Tipo	Flanges Фланцы Flange			
	(k) DNa	(l) PN	(r) DNm	(s) PN
	[mm]	[bar]	[mm]	[bar]
PMXLT	200	25	150	40
PMXLST	200	25	150	63

Plugs Пробки Tappi		
J	K	W
G3/4	G1/2	G1/4

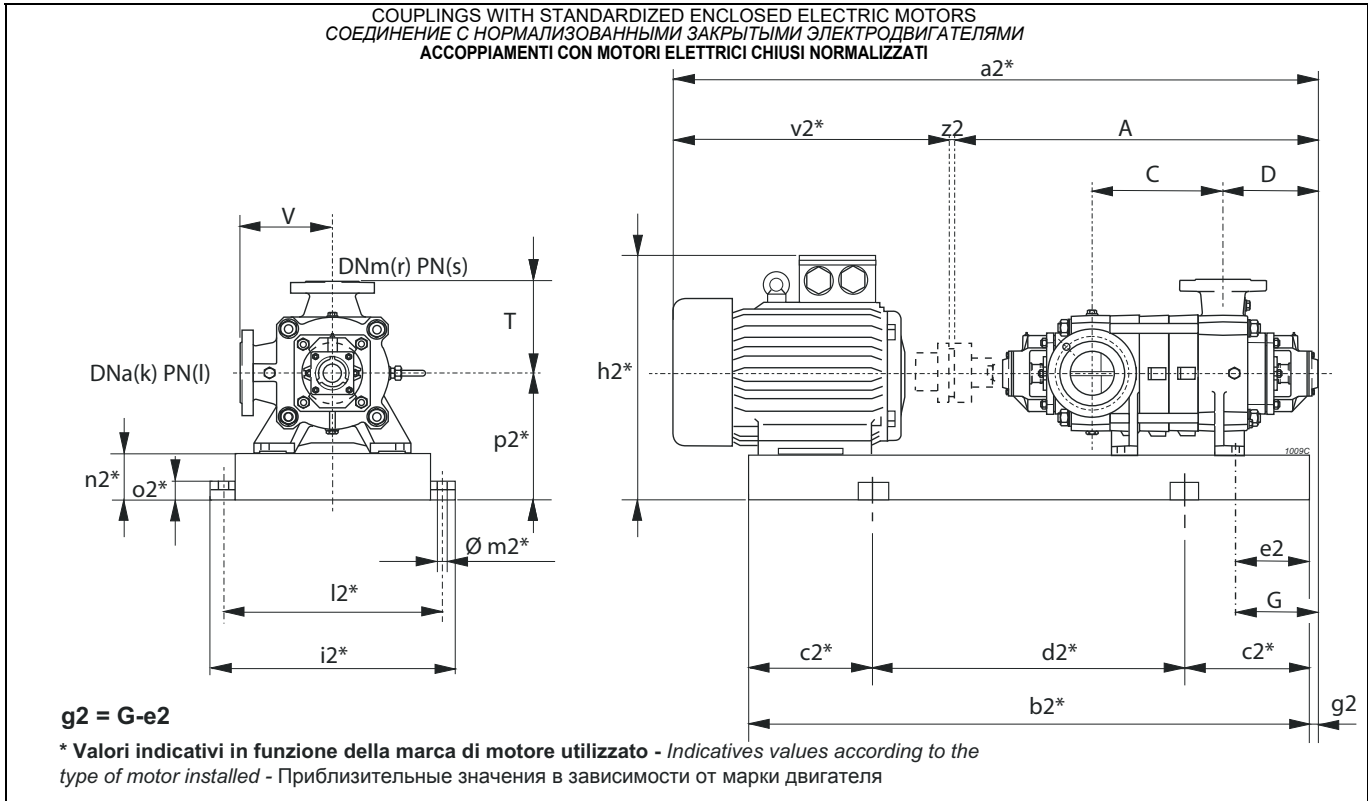

Pump Насос Помпа		Motor Двигатель Motore		BGAM	A	C	D	G	T	V	a2*	b2*	c2*	d2*	e2	h2*	i2*	k	l	l2*	m2*	n2*	o2*	p2*	r	s	v2*	z2	Weight Вес Peso	
Series Серия Serie	Type Тип Tipo	[kW]	Size Размер Grand.	Type Тип Tipo	[mm]																									[kg]
PMXL(S)T	150/2	160	315L	825/IS	1190	360	351	301	370	370	2485	1925	300	1325	60	1030	810	200	25	760	22	160	50	475	150	(2)	1291	4	1960	
PMXL(S)T	/2	200	315L	824/IE4/LS	1190	360	351	301	370	370	2575	1925	300	1325	60	1030	810	200	25	760	22	160	50	475	150	(2)	1381	4	1965	
PMXL(S)T	/2	250	355M	823/LS	1190	360	351	301	370	370	2720	2019	350	1319	100	1136	880	200	25	830	22	180	50	535	150	(2)	1526	4	2472	
PMXL(S)T	/2	280	355L	823/LS	1190	360	351	301	370	370	2720	2019	350	1319	100	1136	880	200	25	830	22	180	50	535	150	(2)	1526	4	2597	
PMXL(S)T	/2	315	355L	823/MS	1190	360	351	301	370	370	2720	2089	350	1389	100	1136	880	200	25	830	22	180	50	535	150	(2)	1526	4	2601	
PMXL(S)T	/2	355	355L	823/MS	1190	360	351	301	370	370	2720	2089	350	1389	100	1136	880	200	25	830	22	180	50	535	150	(2)	1526	4	2591	
PMXL(S)T	150/3	250	355M	826/LS	1315	485	351	301	370	370	2845	2144	350	1444	100	1136	880	200	25	830	22	180	50	535	150	(2)	1526	4	2554	
PMXL(S)T	/3	280	355L	826/LS	1315	485	351	301	370	370	2845	2144	350	1444	100	1136	880	200	25	830	22	180	50	535	150	(2)	1526	4	2679	
PMXL(S)T	/3	315	355L	826/MS	1315	485	351	301	370	370	2845	2214	350	1514	100	1136	880	200	25	830	22	180	50	535	150	(2)	1526	4	2683	
PMXL(S)T	/3	355	355L	826/MS	1315	485	351	301	370	370	2845	2214	350	1514	100	1136	880	200	25	830	22	180	50	535	150	(2)	1526	4	2673	
PMXL(S)T	150/4	315	355L	827/MS	1440	610	351	301	370	370	2970	2339	400	1539	100	1136	880	200	25	830	22	180	50	535	150	(2)	1526	4	2765	
PMXL(S)T	/4	355	355L	827/MS	1440	610	351	301	370	370	2970	2339	400	1539	100	1136	880	200	25	830	22	180	50	535	150	(2)	1526	4	2755	

BGAM = Base and coupling

* = Indicatives values according to the type of motor installed.

○ Motor in IE4 efficiency class according to EU REGULATION 2019/1781. Available in other efficiency classes for non-EU markets.

(2) PMXLT=40 bar PMXLST=63 bar

BGAMA = Рама и муфта

* = Приблизит. значения в зависимости от марки двигателя.

○ Двигатель класса эффективности IE4 в соответствии с РЕГЛАМЕНТОМ ЕС 2019/1781. Имеются варианты в других классах эффективности для рынков за пределами ЕС.

(2) PMXLT=40 бар PMXLST=63 бар

BGAM = Base giunto e coprigiunto

* = Valori indicativi in funzione della marca di motore utilizzato.

○ Motore in classe di efficienza IE4 in conformità al REGOLAMENTO UE2019/1781. Disponibili in altre classi di efficienza per mercati extra UE.

(2) PMXLT=40 bar PMXLST=63 bar

Selection - dimensions and weights for base mounted electric pumps
 Подбор - забариты и вес электронасосов на раме
 Selezione - dimensioni e pesi elettropompe su base

COUPLINGS WITH STANDARDIZED ENCLOSED ELECTRIC MOTORS
 СОЕДИНЕНИЕ С НОРМАЛИЗОВАННЫМИ ЗАКРЫТЫМИ ЭЛЕКТРОДВИГАТЕЛЯМИ
 ACCORPIAMENTI CON MOTORI ELETTRICI CHIUSI NORMALIZZATI

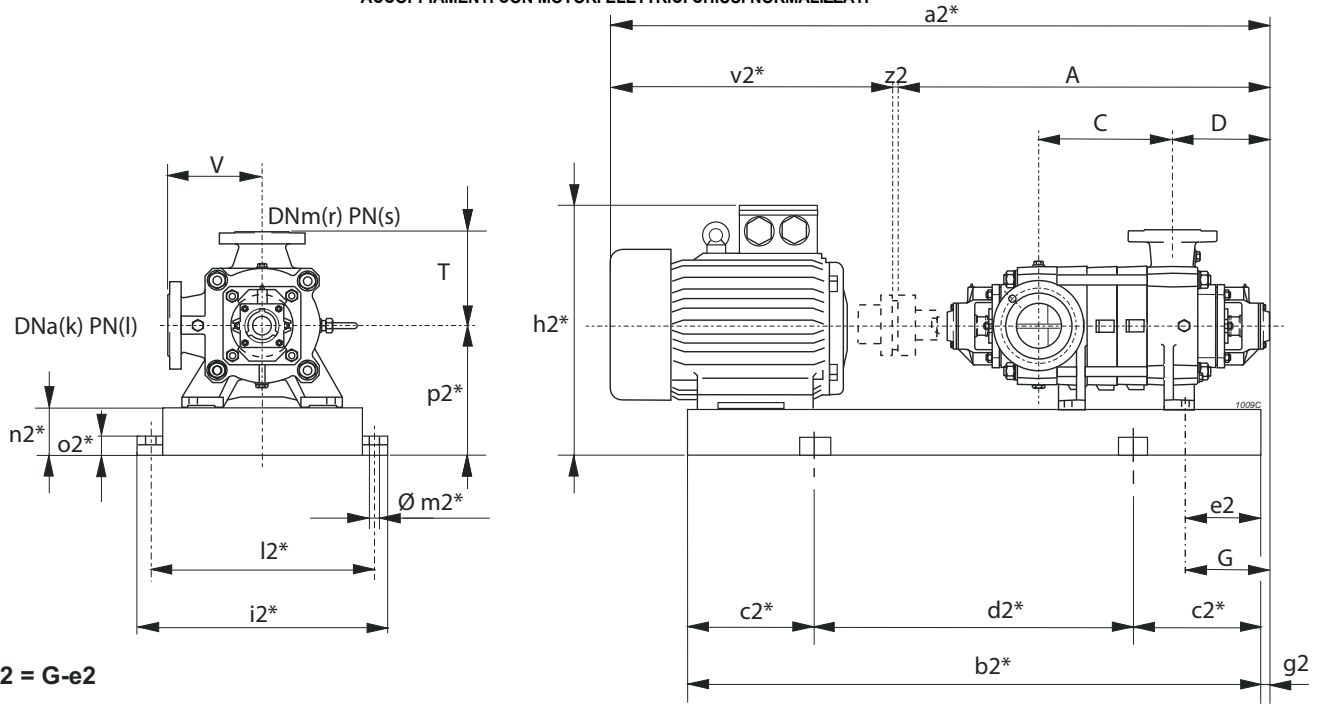

$g2 = G - e2$

* Valori indicativi in funzione della marca di motore utilizzato - Indicatives values according to the type of motor installed - Приблизительные значения в зависимости от марки двигателя

Pump Насос Pompa		Motor Двигатель Motore		BGAM	A	C	D	G	T	V	a2*	b2*	c2*	d2*	e2	h2*	i2*	k	l	l2*	m2*	n2*	o2*	p2*	r	s	v2*	z2	Weight Вес Peso			
Series Серия Serie	Type Тип Tipo	[kW]	Size Размер Grand.	Type Тип Tipo	[mm]																											[kg]
PMXL(S)T	150/2	18,5	180M	829/FP	1190	360	351	301	370	370	1859	1500	250	1000	60	745	810	200	25	760	22	160	50	475	150	(2)	665	4	992			
PMXL(S)T	/2	22	180L	828/FP	1190	360	351	301	370	370	1899	1538	250	1038	60	745	810	200	25	760	22	160	50	475	150	(2)	705	4	1013			
PMXL(S)T	/2	30	200L	856/GP	1190	360	351	301	370	370	1952	1573	250	1073	60	775	810	200	25	760	22	160	50	475	150	(2)	758	4	1067			
PMXL(S)T	/2	37	225S	855/HR	1190	360	351	301	370	370	1987	1604	250	1104	60	805	810	200	25	760	22	160	50	475	150	(2)	793	4	1150			
PMXL(S)T	/2	45	225M	705/HR	1190	360	351	301	370	370	2012	1629	250	1129	60	805	810	200	25	760	22	160	50	475	150	(2)	818	4	1193			
PMXL(S)T	150/3	30	200L	832/GP	1315	485	351	301	370	370	2077	1698	300	1098	60	775	810	200	25	760	22	160	50	475	150	(2)	758	4	1145			
PMXL(S)T	/3	37	225S	831/HR	1315	485	351	301	370	370	2112	1729	300	1129	60	805	810	200	25	760	22	160	50	475	150	(2)	793	4	1229			
PMXL(S)T	/3	45	225M	830/HR	1315	485	351	301	370	370	2137	1754	300	1154	60	805	810	200	25	760	22	160	50	475	150	(2)	818	4	1272			
PMXL(S)T	/3	55	250M	857/IR	1315	485	351	301	370	370	2199	1796	300	1196	60	850	810	200	25	760	22	160	50	475	150	(2)	880	4	1344			
PMXL(S)T	/3	75	280S	708/IR	1315	485	351	301	370	370	2332	1843	300	1243	60	870	810	200	25	760	22	160	50	475	150	(2)	1013	4	1490			
PMXL(S)T	150/4	37	225S	834/HR	1440	610	351	301	370	370	2237	1854	300	1254	60	805	810	200	25	760	22	160	50	475	150	(2)	793	4	1307			
PMXL(S)T	/4	45	225M	833/HR	1440	610	351	301	370	370	2262	1879	300	1279	60	805	810	200	25	760	22	160	50	475	150	(2)	818	4	1350			
PMXL(S)T	/4	55	250M	859/IR	1440	610	351	301	370	370	2324	1921	300	1321	60	850	810	200	25	760	22	160	50	475	150	(2)	880	4	1423			
PMXL(S)T	/4	75	280S	858/IR	1440	610	351	301	370	370	2457	1968	350	1268	60	870	810	200	25	760	22	160	50	475	150	(2)	1013	4	1569			
PMXL(S)T	/4	90	280M	711/LR	1440	610	351	301	370	370	2508	2019	350	1319	60	870	810	200	25	760	22	160	50	475	150	(2)	1064	4	1638			
PMXL(S)T	150/5	45	225M	836/HR	1565	735	351	301	370	370	2387	2004	350	1304	60	805	810	200	25	760	22	160	50	475	150	(2)	818	4	1429			
PMXL(S)T	/5	55	250M	861/IR	1565	735	351	301	370	370	2449	2046	350	1346	60	850	810	200	25	760	22	160	50	475	150	(2)	880	4	1502			
PMXL(S)T	/5	75	280S	835/IR	1565	735	351	301	370	370	2582	2093	350	1393	60	870	810	200	25	760	22	160	50	475	150	(2)	1013	4	1647			
PMXL(S)T	/5	90	280M	860/LR	1565	735	351	301	370	370	2633	2144	350	1444	60	870	810	200	25	760	22	160	50	475	150	(2)	1064	4	1717			
PMXL(S)T	/5	110	315S	714/LS	1565	735	351	301	370	370	2780	2220	350	1520	60	1030	810	200	25	760	22	160	50	475	150	(2)	1211	4	2007			
PMXL(S)T	150/6	55	250M	838/IR	1690	860	351	301	370	370	2574	2171	350	1471	60	850	810	200	25	760	22	160	50	475	150	(2)	880	4	1580			
PMXL(S)T	/6	75	280S	837/IR	1690	860	351	301	370	370	2707	2218	350	1518	60	870	810	200	25	760	22	160	50	475	150	(2)	1013	4	1726			
PMXL(S)T	/6	90	280M	863/LR	1690	860	351	301	370	370	2758	2269	400	1469	60	870	810	200	25	760	22	160	50	475	150	(2)	1064	4	1795			
PMXL(S)T	/6	110	315S	862/LS	1690	860	351	301	370	370	2905	2345	400	1545	60	1030	810	200	25	760	22	160	50	475	150	(2)	1211	4	2085			
PMXL(S)T	/6	132	315M	717/MS	1690	860	351	301	370	370	3015	2455	400	1655	60	1030	810	200	25	760	22	160	50	475	150	(2)	1321	4	2213			
PMXL(S)T	/6	160	315L	717/MS	1690	860	351	301	370	370	3015	2455	400	1655	60	1030	810	200	25	760	22	160	50	475	150	(2)	1321	4	2308			
PMXL(S)T	150/7	75	280S	839/IR	1815	985	351	301	370	370	2832	2343	400	1543	60	870	810	200	25	760	22	160	50	475	150	(2)	1013	4	1805			
PMXL(S)T	/7	90	280M	865/LR	1815	985	351	301	370	370	2883	2394	400	1594	60	870	810	200	25	760	22	160	50	475	150	(2)	1064	4	1874			
PMXL(S)T	/7	110	315S	864/LS	1815	985	351	301	370	370	3030	2470	400	1670	60	1030	810	200	25	760	22	160	50	475	150	(2)	1211	4	2164			

BGAM = Base and coupling

* = Приблизит. значения в зависимости от марки

○ Motor in IE4 efficiency class according to EU REGULATION 2019/1781. Available in other efficiency classes for non-EU markets.

(2) PMXL=40 bar PMXLST=63 bar

BGAMA = Рама и муфта

* = Приблизит. значения в зависимости от марки двигателя.

○ Двигатель класса эффективности IE4 в соответствии с РЕГЛАМЕНТОМ ЕС 2019/1781. Имеются варианты в других классах эффективности для рынков за пределами ЕС.

(2) PMXL=40 бар PMXLST=63 бар

BGAM = Base giunto e coprigiunto

* = Valori indicativi in funzione della marca di motore utilizzato.

○ Motore in classe di efficienza IE4 in conformità al REGOLAMENTO UE2019/1781. Disponibili in altre classi di efficienza per mercati extra UE.

(2) PMXL=40 bar PMXLST=63 bar

COUPLINGS WITH STANDARDIZED ENCLOSED ELECTRIC MOTORS
 СОЕДИНЕНИЕ С НОРМАЛИЗОВАННЫМИ ЗАКРЫТЫМИ ЭЛЕКТРОДВИГАТЕЛЯМИ
 ACCOPPIAMENTI CON MOTORI ELETTRICI CHIUSI NORMALIZZATI

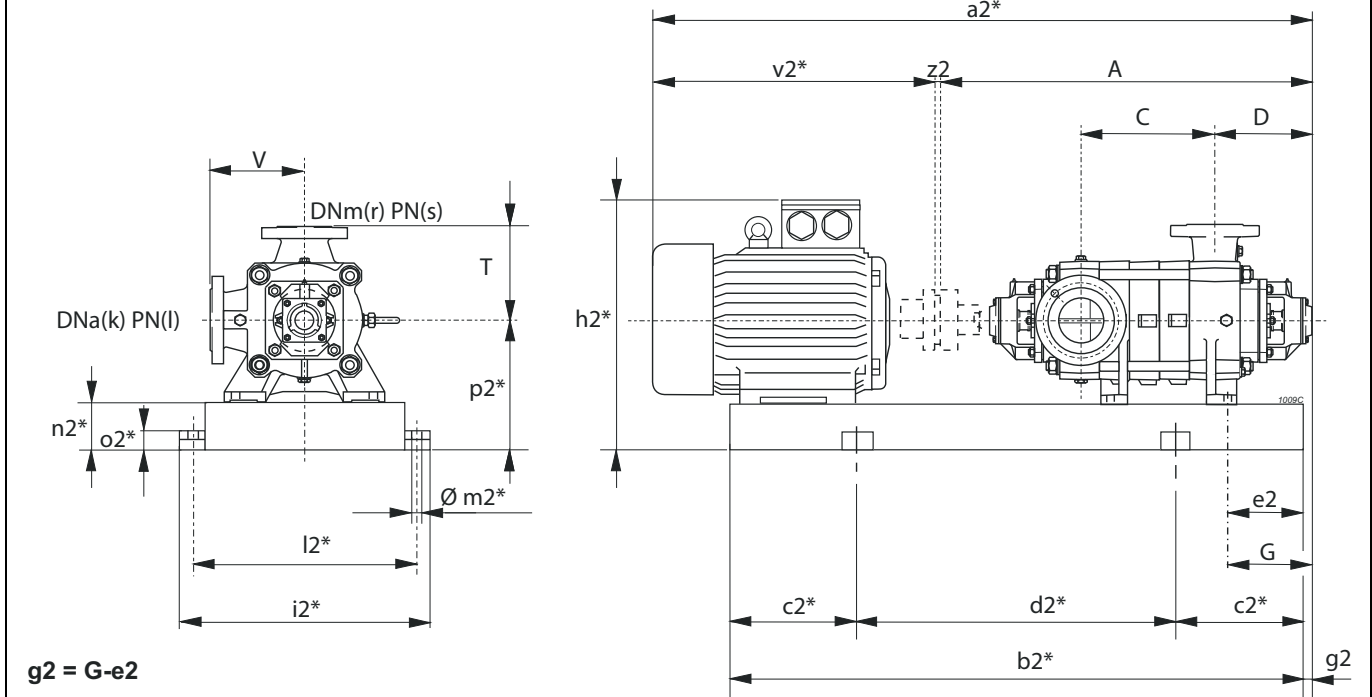

g2 = G-e2

* Valori indicativi in funzione della marca di motore utilizzato - Indicatives values according to the type of motor installed - Приблизительные значения в зависимости от марки двигателя

Pump Насос Помпа	Motor Двигатель Motore	BGAM	A	C	D	G	T	V	a2*	b2*	c2*	d2*	e2	h2*	i2*	k	l	l2*	m2*	n2*	o2*	p2*	r	s	v2*	z2	Weight Bec Peso		
Series Серия Serie	Type Тип Tipo	Size Размер Grand.	Type Тип Tipo	[mm]																						[kg]			
PMXL(S)T	/7	132 ○	315M	720/MS	1815	985	351	301	370	370	3140	2580	450	1680	60	1030	810	200	25	760	22	160	50	475	150	(2)	1321	4	2292
PMXL(S)T	/7	160 ○	315L	720/MS	1815	985	351	301	370	370	3140	2580	450	1680	60	1030	810	200	25	760	22	160	50	475	150	(2)	1321	4	2387
PMXL(S)T	150/8	75 ○	280S	841/IR	1940	1110	351	301	370	370	2957	2468	400	1668	60	870	810	200	25	760	22	160	50	475	150	(2)	1013	4	1883
PMXL(S)T	/8	90 ○	280M	867/LR	1940	1110	351	301	370	370	3008	2519	400	1719	60	870	810	200	25	760	22	160	50	475	150	(2)	1064	4	1953
PMXL(S)T	/8	110 ○	315S	866/LS	1940	1110	351	301	370	370	3155	2595	450	1695	60	1030	810	200	25	760	22	160	50	475	150	(2)	1211	4	2243
PMXL(S)T	/8	132 ○	315M	840/MS	1940	1110	351	301	370	370	3265	2654	450	1754	60	1030	810	200	25	760	22	160	50	475	150	(2)	1321	4	2369
PMXL(S)T	/8	160 ○	315L	840/MS	1940	1110	351	301	370	370	3265	2654	450	1754	60	1030	810	200	25	760	22	160	50	475	150	(2)	1321	4	2464
PMXL(S)T	/8	200 ○	315L	723/IE4/NS	1940	1110	351	301	370	370	3355	2795	450	1895	198	1030	810	200	25	760	22	160	50	475	150	(2)	1411	4	2617
PMXL(S)T	150/9	90 ○	280M	844/LR	2065	1235	351	301	370	370	3133	2644	450	1744	60	870	810	200	25	760	22	160	50	475	150	(2)	1064	4	2031
PMXL(S)T	/9	110 ○	315S	868/LS	2065	1235	351	301	370	370	3280	2720	450	1820	60	1030	810	200	25	760	22	160	50	475	150	(2)	1211	4	2321
PMXL(S)T	/9	132 ○	315M	843/MS	2065	1235	351	301	370	370	3390	2779	450	1879	60	1030	810	200	25	760	22	160	50	475	150	(2)	1321	4	2448
PMXL(S)T	/9	160 ○	315L	843/MS	2065	1235	351	301	370	370	3390	2779	450	1879	60	1030	810	200	25	760	22	160	50	475	150	(2)	1321	4	2543
PMXL(S)T	/9	200 ○	315L	842/IE4/NS	2065	1235	351	301	370	370	3480	2920	500	1920	198	1030	810	200	25	760	22	160	50	475	150	(2)	1411	4	2696
PMXL(S)T	150/10	90 ○	280M	848/LR	2190	1360	351	301	370	370	3258	2769	450	1869	60	870	810	200	25	760	22	160	50	475	150	(2)	1064	4	2110
PMXL(S)T	/10	110 ○	315S	869/LS	2190	1360	351	301	370	370	3405	2845	450	1945	60	1030	810	200	25	760	22	160	50	475	150	(2)	1211	4	2400
PMXL(S)T	/10	132 ○	315M	847/MS	2190	1360	351	301	370	370	3515	2904	500	1904	60	1030	810	200	25	760	22	160	50	475	150	(2)	1321	4	2526
PMXL(S)T	/10	160 ○	315L	847/MS	2190	1360	351	301	370	370	3515	2904	500	1904	60	1030	810	200	25	760	22	160	50	475	150	(2)	1321	4	2621
PMXL(S)T	/10	200 ○	315L	846/IE4/NS	2190	1360	351	301	370	370	3605	3045	500	2045	198	1030	810	200	25	760	22	160	50	475	150	(2)	1411	4	2775
PMXL(S)T	/10	250	355M	845/NS	2190	1360	351	301	370	370	3750	3089	500	2089	100	1136	880	200	25	830	22	180	50	535	150	(2)	1556	4	3149

BGAM = Base and coupling

* = Indicatives values according to the type of motor installed.

○ Motor in IE4 efficiency class according to EU REGULATION 2019/1781. Available in other efficiency classes for non-EU markets.

(2) PMXLT=40 bar PMXLST=63 bar

BGAMA = Рама и муфта

* = Приблизит. значения в зависимости от марки двигателя.

○ Двигатель класса эффективности IE4 в соответствии с РЕГЛАМЕНТОМ ЕС 2019/1781. Имеются варианты в других классах эффективности для рынков за пределами ЕС.

(2) PMXLT=40 бар PMXLST=63 бар

BGAM = Base giunto e coprigiunto

* = Valori indicativi in funzione della marca di motore utilizzato.

○ Motore in classe di efficienza IE4 in conformità al REGOLAMENTO UE2019/1781. Disponibili in altre classi di efficienza per mercati extra UE.

(2) PMXLT=40 bar PMXLST=63 bar

Utilization field Область применения Campo di utilizzo ≥ 60% η		
Stage number: compatibly with the maximum pressure. Кол-во ступеней: совместимое с макс. давлением. Numero stadi: compatibilmente con la pressione massima di esercizio.		
Type Тип Tipo	MIN.	MAX.
PMXT	2	8
PMXST	2	8
NB. For two-stage pumps only, reduce efficiency by one point. Только для двухступенчатых насосов - снизить КПД на 1 единицу Solamente per le pompe a due stadi, ridurre di un punto il rendimento.		

Wet moment of inertia J Момент инерции J мокрый Momento d'inerzia J bagnato J=1/4PD ² - [kg m ²]		
Impeller type Тип раб. колеса Girante tipo	PMX(S)T150/1	For each additional stage Для каждой доп. ступени Per ogni stadio in più
Stainless steel Нержав. сталь Acciaio inox	0,1738	0,1443

Maximum permissible power Макс. допустимая мощность Massime potenze ammissibili	
Type Тип Tipo	N/n MAX.
PMXT	0,31
PMXST	0,31
For seal limits and calculation formulas of the maximum permissible powers, see technical data section. Ограничения по уплотнениям и формулы расчета макс. допустимой мощности - см. раздел "Технические данные". Per i limiti tenete e le formule di calcolo delle massime potenze ammissibili, vedere sezione dati tecnici.	

PERFORMANCES EACH INTERMEDIATE STAGE
ХАРАКТЕРИСТИКИ ОДНОЙ СТУПЕНИ
PRESTAZIONI PER STADIO

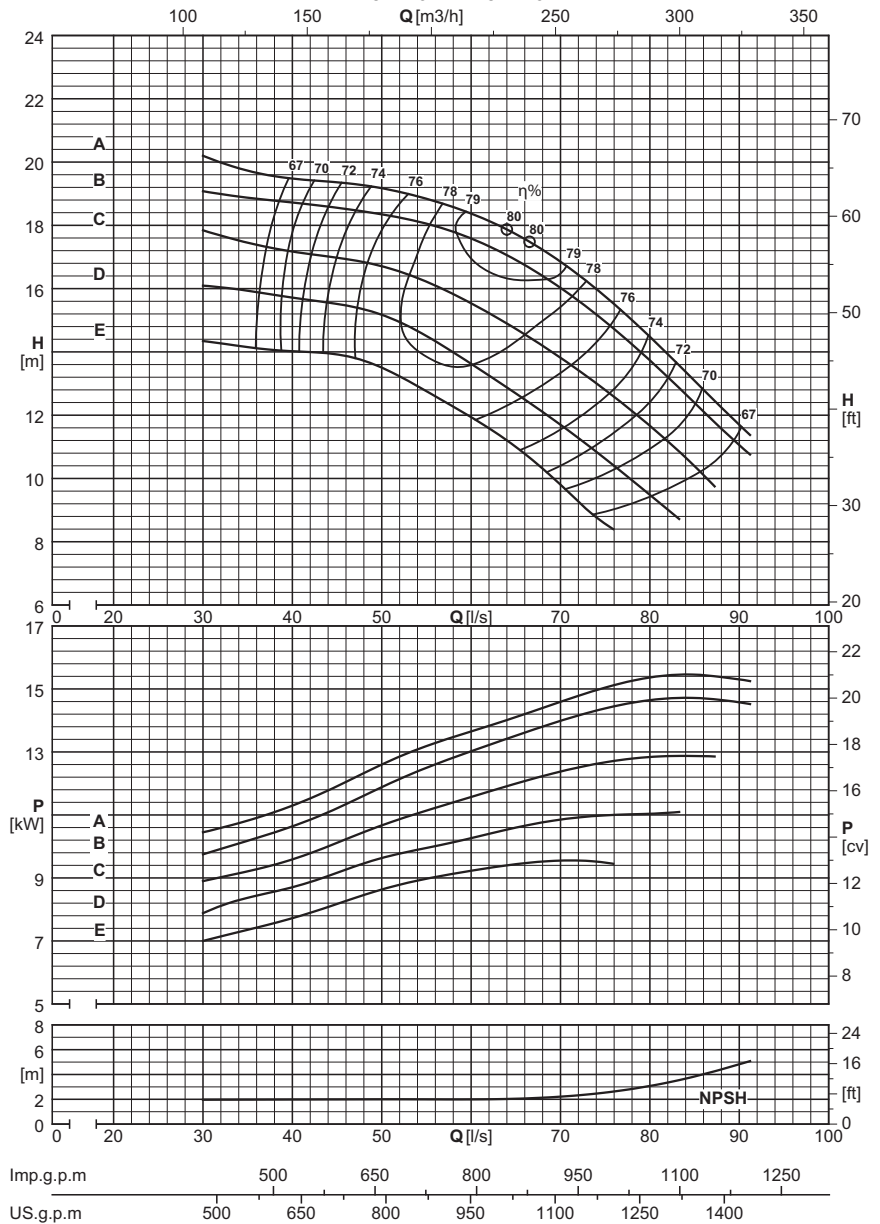

		Capacity - Расход - Portata																								
Dna x DNm	Impeller type Тип раб. кол. / Girante tipo	[l/s]	0	50	52	54	56	58	60	62	64	66	68	70	72	74	76	78	80	82	84	86	88	90		
		[m³/h]	0	180	187,2	194,4	201,6	208,8	216	223,2	230,4	237,6	244,8	252	259,2	266,4	273,6	280,8	288	295,2	302,4	309,6	316,8	324		
		[l/min]	0	3000	3120	3240	3360	3480	3600	3720	3840	3960	4080	4200	4320	4440	4560	4680	4800	4920	5040	5160	5280	5400		
PMX(S)T150/1																										
200x150	E	[m]	16,5	13,5	13	13	12,5	12,5	12	11,5	11	11	10	9,7	9,4	8,8	8,4									
200x150	E	[kW]		8,7	8,8	8,9	9	9	9,3	9,4	9,4	9,4	9,4	9,4	9,7	9,6	9,5									
200x150	D	[m]	18,5	15	15,5	15	14,5	14,5	13,5	13	13	12,5	12	11,5	11,5	11	10,5	10	9,4	8,9	8,6					
200x150	D	[kW]		9,7	9,7	9,7	10,1	10,1	10,2	10,5	10,6	10,6	10,6	10,9	10,9	10,9	11,2	11,1	11	10,9	11,2					
200x150	C	[m]	21	17,5	16,5	16,5	16,5	15,5	15,5	15,5	15	14,5	14	14	13,5	13,5	12,5	12	11,5	11,5	10,5	9,9	9,7			
200x150	C	[kW]		10,5	11	11	11,1	11,5	11,6	11,6	12	12,1	12,1	12,5	12,5	12,5	12,8	12,8	12,7	13	12,8	12,7	13			
200x150	B	[m]	22,5	18	18,5	17,5	18	19	17,5	17,5	17	16,5	16,5	16,5	15,5	15	15	14	13,5	13,5	12,5	12,5	11,5	11		
200x150	B	[kW]		12	12,1	12,5	12,6	12,7	13,1	13,2	13,3	13,7	13,7	14,1	14,2	14,2	14,6	14,5	14,4	14,8	14,6	14,9	14,7	14,3		
200x150	A	[m]	23,5	19	19	18,5	18,5	19	18	18	18	17,5	17,5	17	16,5	16,5	15,5	15,5	14,5	14,5	13,5	13,5	12	11,5		
200x150	A	[kW]		12,7	12,8	13,3	13,3	13,3	13,8	13,8	13,8	14,3	14,3	14,7	14,8	14,8	15	15	15	15,5	15,5	15,5	15,5	15		
NPSH																										
		[m]		2	2	2	2	2	2	2	2,1	2,1	2,2	2,3	2,4	2,6	2,9	3,1	3,3	3,7	3,9	4,4	5			

Utilization field Область применения Campo di utilizzo ≥ 60% η		
Stage number: compatibly with the maximum pressure. Кол-во ступеней: совместимое с макс. давлением. Numero stadi: compatibilmente con la pressione massima di esercizio.		
Type Тип Tipo	MIN.	MAX.
PMXT	2	8
PMXST	2	8
NB. For two-stage pumps only, reduce efficiency by one point. Только для двухступенчатых насосов - снизить КПД на 1 единицу Solamente per le pompe a due stadi, ridurre di un punto il rendimento.		

Wet moment of inertia J Момент инерции J мокрый Momento d'inerzia J bagnato $J = \frac{1}{4}PD^2$ - [kg m ²]		
Impeller type Тип раб. колеса Girante tipo	PMX(S)T150/1	For each additional stage Для каждой доп. ступени Per ogni stadio in più
Stainless steel Нержав. сталь Acciaio inox	0,1738	0,1443

Maximum permissible power Макс. допустимая мощность Massime potenze ammissibili	
Type Тип Tipo	N/n MAX.
PMXT	0,31
PMXST	0,31
For seal limits and calculation formulas of the maximum permissible powers, see technical data section. Ограничения по уплотнениям и формулы расчета макс. допустимой мощности - см. раздел "Технические данные". Per i limiti tenute e le formule di calcolo delle massime potenze ammissibili, vedere sezione dati tecnici.	

PERFORMANCES EACH INTERMEDIATE STAGE
ХАРАКТЕРИСТИКИ ОДНОЙ СТУПЕНИ
PRESTAZIONI PER STADIO

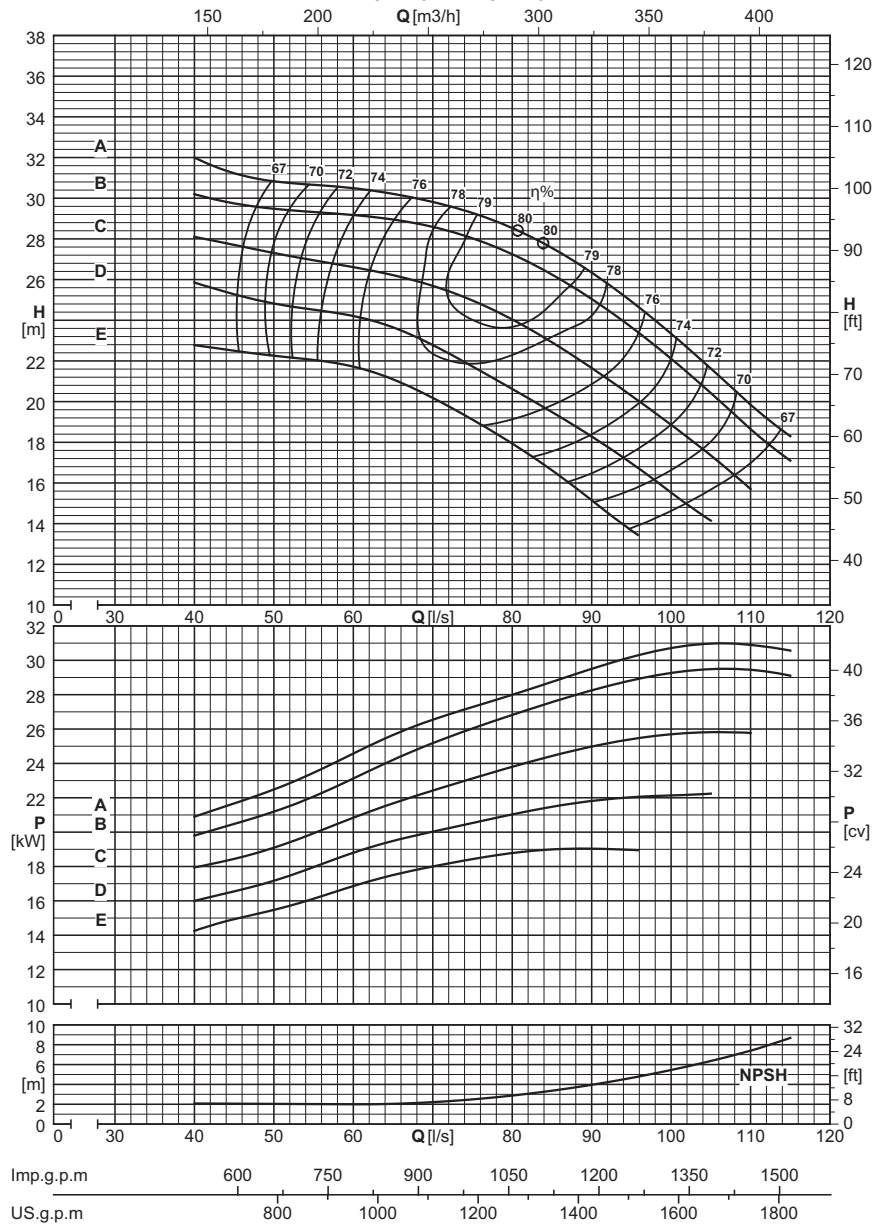

Dna x Dnm	Impeller type Тип раб. кол. / Girante tipo	Capacity - Расход - Portata																
		[l/s]	0	60	64	68	72	76	80	84	88	92	96	100	104	108	112	116
		[m ³ /h]	0	216	230,4	244,8	259,2	273,6	288	302,4	316,8	331,2	345,6	360	374,4	388,8	403,2	417,6
		[l/min]	0	3600	3840	4080	4320	4560	4800	5040	5280	5520	5760	6000	6240	6480	6720	6960
PMX(S)T150/1																		
200x150	E	[m]	26,5	22	21	20,5	20	19	18	17	16	14,5	13,5					
200x150	E	[kW]		17	17,5	17,5	18	18,5	18,5	20	19,5	19	20					
200x150	D	[m]	29,5	24,5	24	23	22	21,5	20,5	19,5	19	18	17	15,5	14,5	14		
200x150	D	[kW]		18,5	19,5	20	20,5	21	21,5	21,5	22	22,5	22	22	22	23		
200x150	C	[m]	33,5	26,5	27	26,5	25,5	25	24	23	22	21	20	20	18	16,5	15,5	
200x150	C	[kW]		21	21	22	22,5	23	23,5	24,5	25	25	25,5	26	26	26	26	
200x150	B	[m]	35,5	29	29	28,5	28,5	28	27	26,5	25,5	24,5	23,5	22	21	19,5	18	17,5
200x150	B	[kW]		23	24,5	25	25,5	26,5	27	27,5	28	28,5	29	29,5	29,5	30	29,5	29,5
200x150	A	[m]	36,5	30,5	30	30	29,5	30	28,5	27,5	27	26	24,5	23,5	22	20,5	19,5	18
200x150	A	[kW]		24,5	25,5	26,5	27	27,5	28	28,5	29,5	30	30,5	31	31	31	31	31
NPSH																		
		[m]		2	2	2,1	2,3	2,5	2,8	3,3	3,7	4,2	4,8	5,4	6,1	6,8	7,7	8,8

Utilization field Область применения Campo di utilizzo ≥ 60% η		
Stage number: compatibly with the maximum pressure. Кол-во ступеней: совместимое с макс. давлением. Numero stadi: compatibilmente con la pressione massima di esercizio.		
Type Тип Tipo	MIN.	MAX.
PMXT	2	6
PMXST	2	6
NB. For two-stage pumps only, reduce efficiency by one point. Только для двухступенчатых насосов - снизить КПД на 1 единицу Solamente per le pompe a due stadi, ridurre di un punto il rendimento.		

Wet moment of inertia J Момент инерции J мокрый Momento d'inerzia J bagnato $J = \frac{1}{4}PD^2 - [kg\ m^2]$		
Impeller type Тип раб. колеса Girante tipo	PMX(S)T150/1	For each additional stage Для каждой доп. ступени Per ogni stadio in più
Stainless steel Нержав. сталь Acciaio inox	0,1738	0,1443

Maximum permissible power Макс. допустимая мощность Massime potenze ammissibili	
Type Тип Tipo	N/n MAX.
PMXT	0,31
PMXST	0,31
For seal limits and calculation formulas of the maximum permissible powers, see technical data section. Ограничения по уплотнениям и формулы расчета макс. допустимой мощности - см. раздел "Технические данные". Per i limiti tenute e le formule di calcolo delle massime potenze ammissibili, vedere sezione dati tecnici.	

PERFORMANCES EACH INTERMEDIATE STAGE
ХАРАКТЕРИСТИКИ ОДНОЙ СТУПЕНИ
PRESTAZIONI PER STADIO

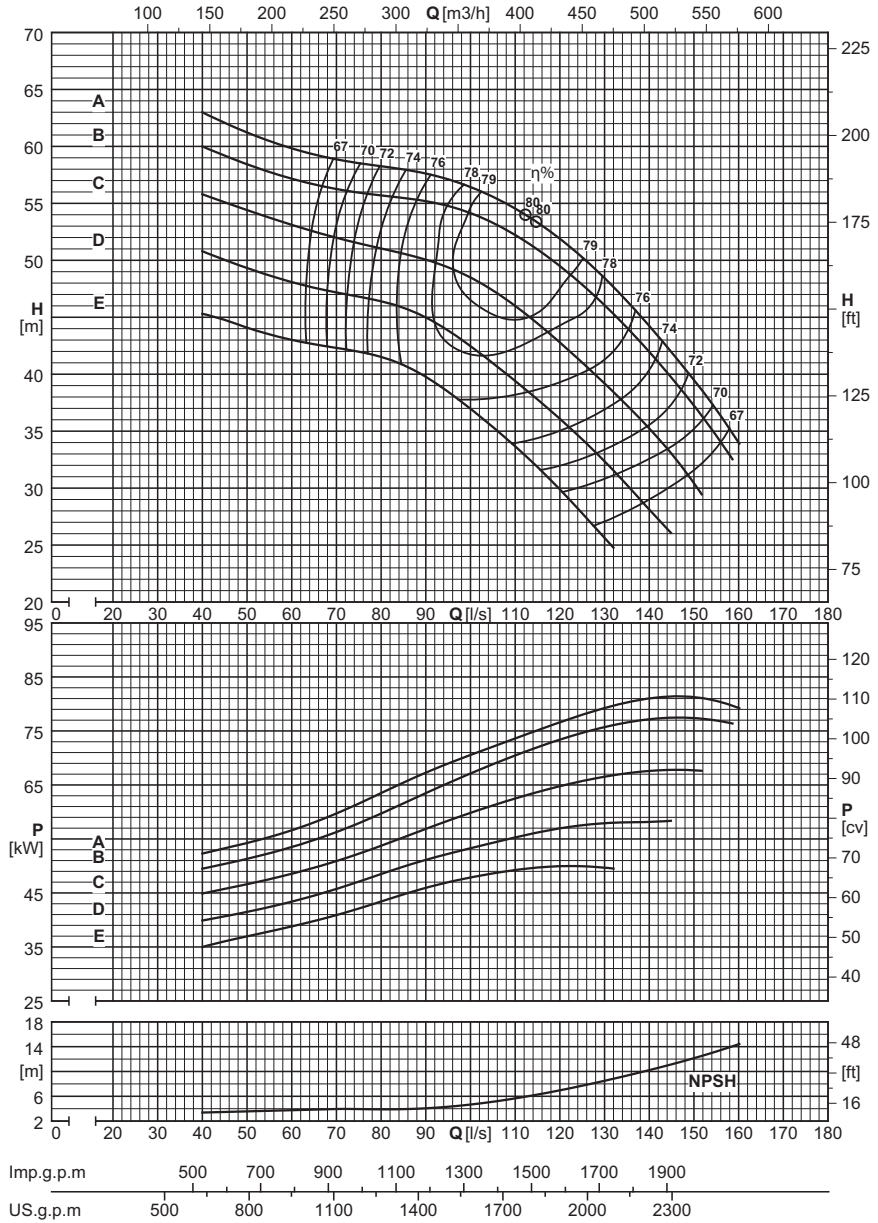

Dna x Dnm	Impeller type Тип раб. кол. Girante tipo	Capacity - Расход - Portata																					
		[l/s]	0	84	88	92	96	100	104	108	112	116	120	124	128	132	136	140	144	148	152	156	160
		[m³/h]	0	302,4	316,8	331,2	345,6	360	374,4	388,8	403,2	417,6	432	446,4	460,8	475,2	489,6	504	518,4	532,8	547,2	561,6	576
		[l/min]	0	5040	5280	5520	5760	6000	6240	6480	6720	6960	7200	7440	7680	7920	8160	8400	8640	8880	9120	9360	9600

		PMX(S)T150/1																					
200x150	E	[m]	50	41	40,5	39,5	38,5	37	35,5	34,5	33	31,5	29,5	28,5	26,5	25							
200x150	E	[kW]		44,5	45,5	46,5	46,5	48,5	49	49	49	49	50	50,5	50	49,5							
200x150	D	[m]	56	46,5	46	44	43,5	42,5	41,5	40	39	37,5	36	34,5	33	31	30,5	28,5					
200x150	D	[kW]		49,5	50	52,5	52,5	53	53,5	55,5	55,5	56,5	58	58	57,5	57,5	60	58,5					
200x150	C	[m]	62	49	50	50	50	48	47,5	47	45	44	43	41,5	40	38	37	35	33,5	32	29,5		
200x150	C	[kW]		56,5	56,5	57	58	60	60,5	61	63,5	64	64,5	66	66	66,5	69	67,5	67	69	67,5		
200x150	B	[m]	67	55	56	54	54	55	52	52	52	50	49,5	49	47	45	44	42	39,5	38,5	36	33	32,5
200x150	B	[kW]		61,5	62	65	65,5	66,5	70	69,5	70	72,5	73,5	75	75	75	77	77	76	78	77	75	77
200x150	A	[m]	69	58	59	56	57	55	55	55	53	53	52	50	49	47,5	46	44	43	40,5	39	37,5	34
200x150	A	[kW]		65,5	65,5	68,5	69	72	72	72,5	75	75	75	78	78	78	80	80	82	81	79	81	79

		NPSH																					
		[m]		3,9	4	4,2	4,4	4,7	5,1	5,4	5,9	6,4	7,1	7,4	8,2	8,8	9,4	10,2	11,1	11,7	12,5	13,1	14,4

Overall dimensions and weights
 Общие габариты и вес
 Dimensioni di ingombro e pesi

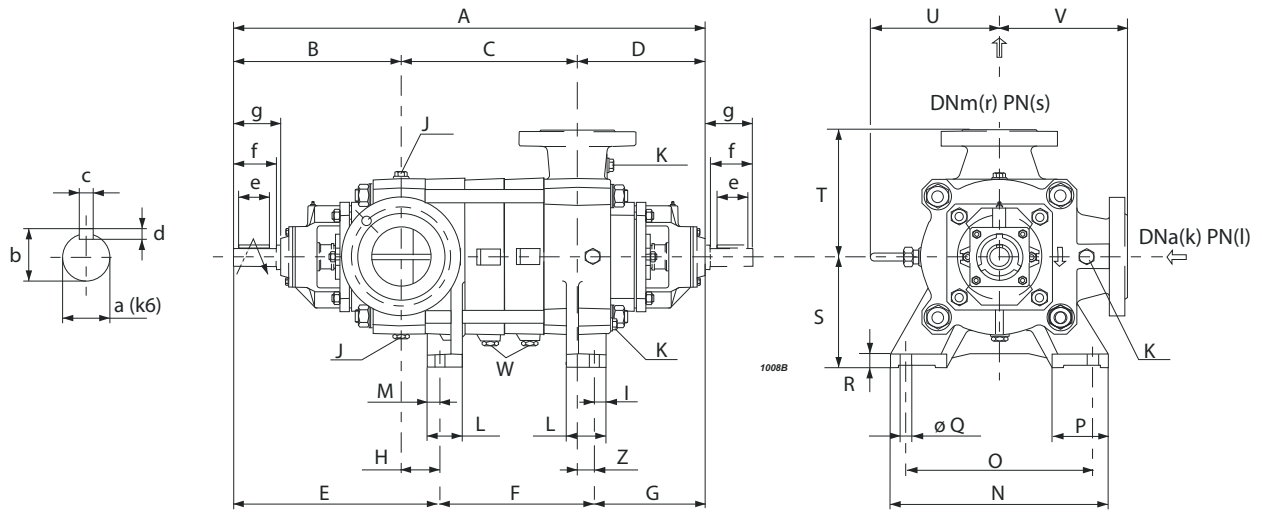

Series Серия Serie	Type Тип Tipo	A	B	C	D	E	F	G	H	S	T	U	V	Z	Weight Вес Peso
		[mm]													[kg]
PMX(S)T	150/2	1190	479	360	351	619	270	301	140	315	370	358	370	50	711
PMX(S)T	150/3	1315	479	485	351	619	395	301	140	315	370	358	370	50	791
PMX(S)T	150/4	1440	479	610	351	619	520	301	140	315	370	358	370	50	872
PMX(S)T	150/5	1565	479	735	351	619	645	301	140	315	370	358	370	50	953
PMX(S)T	150/6	1690	479	860	351	619	770	301	140	315	370	358	370	50	1033
PMX(S)T	150/7	1815	479	985	351	619	895	301	140	315	370	358	370	50	1114
PMX(S)T	150/8	1940	479	1110	351	619	1020	301	140	315	370	358	370	50	1195

Foot dimensions Размеры ножек Dimensioni dei piedi							
I	L	M	N	O	P	Q	R
[mm]							
43	125	45	680	590	170	24	40

Shaft projection Выступ вала Sporgenza d'albero						
a	b	c	d	e	f	g
[mm]						
55	59	16	10	120	130	145

Type Тип Tipo	Flanges Фланцы Flange			
	(k) DNa	(l) PN	(r) DNm	(s) PN
	[mm]	[bar]	[mm]	[bar]
PMXT	200	25	150	40
PMXST	200	25	150	63

Plugs Заглушки Tappi		
J	K	W
G3/4	G1/2	G1/4

Selection - dimensions and weights for base mounted electric pumps
 Подбор - габариты и вес электронасосов на раме
 Selezione - dimensioni e pesi elettropompe su base

COUPLINGS WITH STANDARDIZED ENCLOSED ELECTRIC MOTORS
 СОЕДИНЕНИЕ С НОРМАЛИЗОВАННЫМИ ЗАКРЫТЫМИ
 ЭЛЕКТРОДВИГАТЕЛЯМИ ACCORRIAMENTI CON MOTORI ELETTRICI CHIUSI

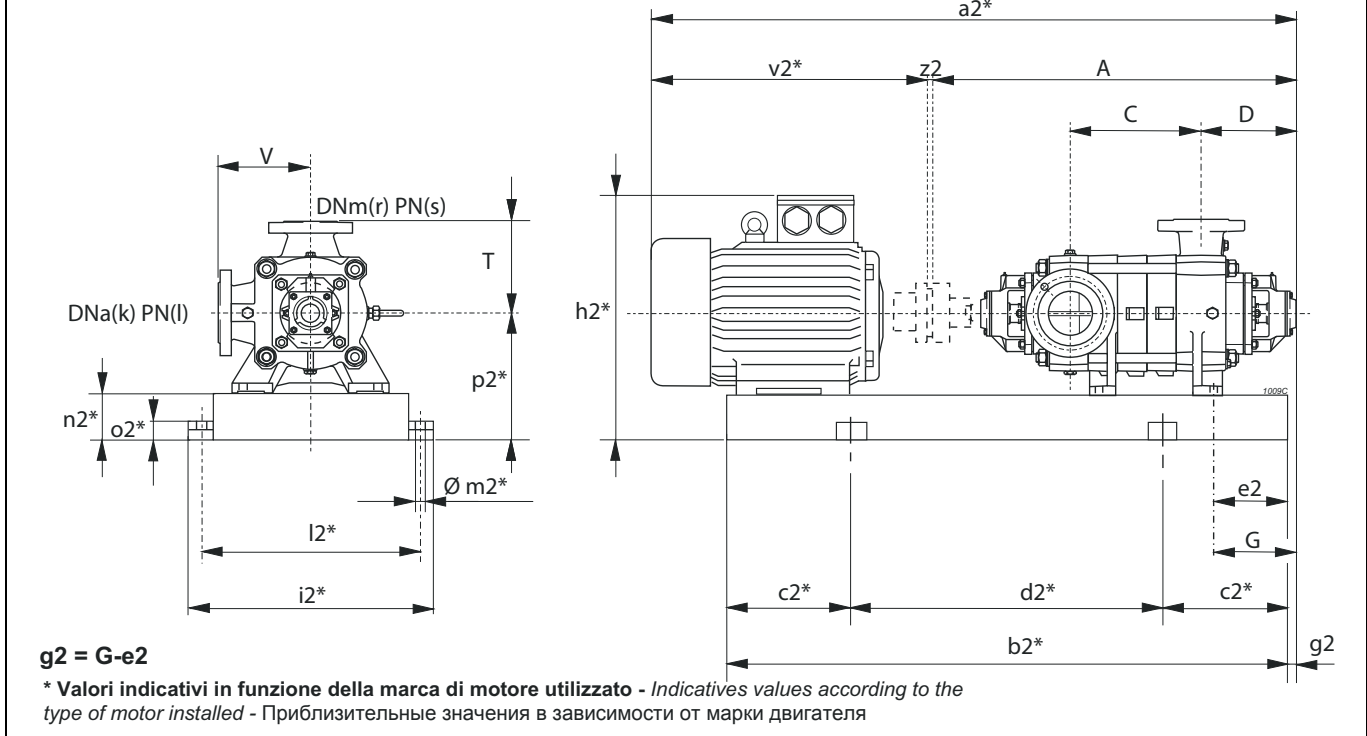

Pump Насос Помпа	Motor Двигатель Motore	BGAM	A	C	D	G	T	V	a2*	b2*	c2*	d2*	e2	h2*	i2*	k	l	l2*	m2*	n2*	o2*	p2*	r	s	v2*	z2	Weight Вес Peso		
Series Серия Serie	Type Тип Tipo	[kW]	Size Размер Grand.	Type Тип Tipo	[mm]																				[kg]				
PMX(S)T	150/2	45	225M	705/HR	1190	360	351	301	370	370	2074	1671	300	1071	60	850	810	200	25	760	22	160	50	475	150	(2)	880	4	1266
PMX(S)T	/2	55	250M	706/IR	1190	360	351	301	370	370	2207	1718	300	1118	60	870	810	200	25	760	22	160	50	475	150	(2)	1013	4	1411
PMX(S)T	/2	75	280S	707/IR	1190	360	351	301	370	370	2332	1843	300	1243	60	870	810	200	25	760	22	160	50	475	150	(2)	1013	4	1490
PMX(S)T	150/3	75	280S	708/IR	1315	485	351	301	370	370	2383	1894	300	1294	60	870	810	200	25	760	22	160	50	475	150	(2)	1064	4	1559
PMX(S)T	/3	90	280M	709/LR	1315	485	351	301	370	370	2530	1970	350	1270	60	1030	810	200	25	760	22	160	50	475	150	(2)	1211	4	1849
PMX(S)T	/3	110	315S	710/LS	1315	485	351	301	370	370	2530	1970	350	1270	60	1030	810	200	25	760	22	160	50	475	150	(2)	1211	4	1849
PMX(S)T	150/4	90	280M	711/LR	1440	610	351	301	370	370	2508	2019	350	1319	60	870	810	200	25	760	22	160	50	475	150	(2)	1064	4	1638
PMX(S)T	/4	110	315S	712/LS	1440	610	351	301	370	370	2655	2095	350	1395	60	1030	810	200	25	760	22	160	50	475	150	(2)	1211	4	1928
PMX(S)T	/4	132	315M	713/MS	1440	610	351	301	370	370	2765	2205	350	1505	60	1030	810	200	25	760	22	160	50	475	150	(2)	1321	4	2056
PMX(S)T	/4	160	315L	713/MS	1440	610	351	301	370	370	2765	2205	350	1505	60	1030	810	200	25	760	22	160	50	475	150	(2)	1321	4	2151
PMX(S)T	150/5	110	315S	714/LS	1565	735	351	301	370	370	2780	2220	350	1520	60	1030	810	200	25	760	22	160	50	475	150	(2)	1211	4	2007
PMX(S)T	/5	132	315M	715/MS	1565	735	351	301	370	370	2890	2330	400	1530	60	1030	810	200	25	760	22	160	50	475	150	(2)	1321	4	2135
PMX(S)T	/5	160	315L	715/MS	1565	735	351	301	370	370	2890	2330	400	1530	60	1030	810	200	25	760	22	160	50	475	150	(2)	1321	4	2230
PMX(S)T	/5	200	315L	716/IE4/NS	1565	735	351	301	370	370	2980	2420	400	1620	198	1030	810	200	25	760	22	160	50	475	150	(2)	1411	4	2375
PMX(S)T	150/6	132	315M	717/MS	1690	860	351	301	370	370	3015	2455	400	1655	60	1030	810	200	25	760	22	160	50	475	150	(2)	1321	4	2213
PMX(S)T	/6	160	315L	717/MS	1690	860	351	301	370	370	3015	2455	400	1655	60	1030	810	200	25	760	22	160	50	475	150	(2)	1321	4	2308
PMX(S)T	/6	200	315L	718/IE4/NS	1690	860	351	301	370	370	3105	2545	400	1745	198	1030	810	200	25	760	22	160	50	475	150	(2)	1411	4	2460
PMX(S)T	/6	250	355M	719/NS	1690	860	351	301	370	370	3250	2589	450	1689	100	1136	880	200	25	830	22	180	50	535	150	(2)	1556	4	2831
PMX(S)T	150/7	132	315M	720/MS	1815	985	351	301	370	370	3140	2580	450	1680	60	1030	810	200	25	760	22	160	50	475	150	(2)	1321	4	2292
PMX(S)T	/7	160	315L	720/MS	1815	985	351	301	370	370	3140	2580	450	1680	60	1030	810	200	25	760	22	160	50	475	150	(2)	1321	4	2387
PMX(S)T	/7	200	315L	721/IE4/NS	1815	985	351	301	370	370	3230	2670	450	1770	198	1030	810	200	25	760	22	160	50	475	150	(2)	1411	4	2538
PMX(S)T	/7	250	355M	722/NS	1815	985	351	301	370	370	3375	2714	450	1814	100	1136	880	200	25	830	22	180	50	535	150	(2)	1556	4	2911
PMX(S)T	150/8	200	315L	723/IE4/NS	1940	1110	351	301	370	370	3355	2795	450	1895	198	1030	810	200	25	760	22	160	50	475	150	(2)	1411	4	2617
PMX(S)T	/8	250	355M	724/NS	1940	1110	351	301	370	370	3500	2839	450	1939	100	1136	880	200	25	830	22	180	50	535	150	(2)	1556	4	2990
PMX(S)T	/8	280	355L	724/PS	1940	1110	351	301	370	370	3500	2909	500	1909	100	1136	880	200	25	830	22	180	50	535	150	(2)	1556	4	3189
PMX(S)T	/8	315	355L	724/PS	1940	1110	351	301	370	370	3500	2909	500	1909	100	1136	880	200	25	830	22	180	50	535	150	(2)	1556	4	3189

BGAM = Base and coupling * = Приблизит. значения в зависимости от марки
 Motor in IE4 efficiency class according to EU REGULATION 2019/1781. Available in other efficiency classes for non-EU markets.
 BGAMA = Рама и муфта * = Приблизит. значения в зависимости от марки двигателя.
 Motor in IE4 efficiency class according to EU REGULATION 2019/1781. Available in other efficiency classes for non-EU markets.
 BGAM = Base giunto e coprigiunto * = Valori indicativi in funzione della marca di motore utilizzato.
 Motor in classe di efficienza IE4 in conformità al REGOLAMENTO UE2019/1781. Disponibili in altre classi di efficienza per mercati extra UE.
 (2) PMXT=40 bar PMXST=63 bar (2) PMXT=40 бар PMXST=63 бар (2) PMXT=40 bar PMXST=63 бар

Flanges (UNI EN 1092-2)
 Фланцы (UNI EN 1092-2)
 Flange (UNI EN 1092-2)

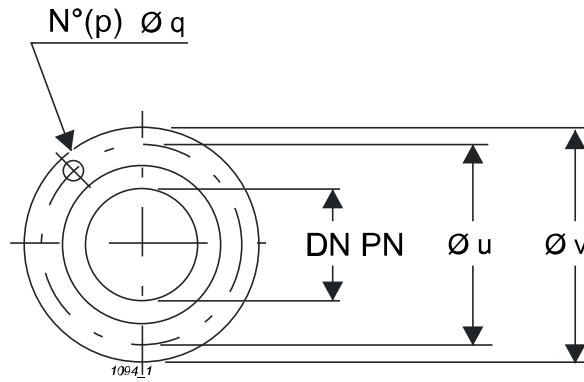

Port \varnothing \varnothing отверстия \varnothing Вовса		Holes Отверстия Fori		$\varnothing u$	$\varnothing v$
DN [mm]	PN [bar]	p No	q \varnothing [mm]	[mm]	
50	40	4	18	125	180
50	63	4	22	135	180
65	25	8	18	145	185
65	40	8	18	145	205
65	63	8	22	160	205
65	100	8	26	170	220
80	25	8	18	160	200
80	40	8	18	160	215
80	63	8	22	170	215
80	100	8	25	180	230
100	25	8	22	190	235
100	40	8	22	190	235
100	63	8	25	200	250
100	100	8	30	210	265
125	25	8	25	220	270
125	40	8	25	220	270
125	63	8	30	240	295
125	100	8	35	250	315
150	25	8	25	250	300
150	40	8	25	250	300
150	63	8	33	280	345
200	25	12	25	310	360

caprari

*The dimensions have an indicative value. Executive drawing will be supplied on request upon order.
CAPRARI S.p.A. reserves the right to make changes to improve its products at any time and without any notice*

Размеры являются ориентировочными. Чертеж будет предоставлен по запросу при заказе. CAPRARI S.p.A. оставляет за собой право вносить изменения с целью улучшения своих продуктов в любое время и без предварительного уведомления.

**Le dimensioni hanno valore indicativo. Il disegno esecutivo sarà fornito su richiesta in fase d'ordine.
CAPRARI S.p.A. si riserva facoltà di apportare modifiche atte a migliorare i propri prodotti in qualsiasi momento e senza preavviso alcuno.**